

ORDINANCE # 22-17

AN ORDINANCE ADOPTING REVISIONS AND AMENDMENTS TO THE SANDY CITY'S STANDARD SPECIFICATIONS AND DETAILS FOR MUNICIPAL CONSTRUCTION AS REQUIRED BY THE UTAH CODE; ALSO PROVIDING A SAVING CLAUSE AND EFFECTIVE DATE FOR THE ORDINANCE.

WHEREAS, Title 10, Chapter 9a, Utah Code Ann. requires land use regulations, including engineering standards such as Sandy City's Standard Specifications and Details for Municipal Construction, to be enacted by ordinance of the City Council; and

WHEREAS, the Planning Commission held a public hearing on November 3, 2022, which meeting was preceded by notice posting in Sandy City Hall, the Sandy City Parks & Recreation Building, Salt Lake County Library – Sandy, on the Sandy City Website – <http://www.sandy.utah.gov>, and the Utah Public Notice Website – <http://pmn.utah.gov> on October 13, 2022; and

WHEREAS, following the public hearing before the Planning Commission, the Commission recommended adoption of the Sandy City's Standard Specifications and Details for Municipal Construction; and

WHEREAS, a public meeting was held by the Sandy City Council on December 6, 2022 to consider adoption of the proposed amendment; and

WHEREAS, the City Council has been given specific authority in Title 10, Chapter 9a, Utah Code Ann. to adopt land use regulations to regulate the erection, construction, reconstruction, alteration, repair and uses of buildings and structures, and the uses of land; and

WHEREAS, the State legislature has granted welfare power to the City Council, independent, apart from, and in addition to, its specific grants of legislative authority, which enables the City to pass ordinances which are reasonable and appropriate to the objectives of that power, i.e., providing for the public safety, health, morals, and welfare; and

WHEREAS, the forgoing legitimate governmental objectives are achieved by reasonable means, in that any adverse impact on private property value or use has been carefully balanced against the corresponding gain to the public; and the regulations have been calculated, on recommendation of City planning staff to permit property owners to beneficially use their properties for the practical purposes to which the property is reasonably adaptable; and procedures have been established by the Land Development Code and Utah Code Ann. Whereby appeals can be heard and decided if it is alleged that there is legislative or administrative error, or where a special exception or variance to the ordinance is required.

NOW, THEREFORE, BE IT ORDAINED by the City Council of Sandy City, State of Utah, as follows:

Section 1. Adoption. The revisions to the Sandy City's Standard Specifications and Details for Municipal Construction are hereby approved and adopted as set forth in **Exhibit "A"**, which is attached to and incorporated in this ordinance.

Section 2. Severable. If any part of this ordinance or the application thereof to any person or circumstances shall, for any reason, be adjudged by a court of competent jurisdiction to be unconstitutional or invalid, such judgement shall not affect, impair or invalidate the remainder of this ordinances or the application thereof to other persons and circumstances, but shall be confined in its operation to the section, subdivision, sentence or part of the section and the persons and circumstances directly involved in the controversy in which such judgment shall have been rendered. It is hereby declared to be the intent of the City Council that this section would have been adopted of such invalid section, provisions, subdivision, sentence or part of a section or application had not been included.

Section 3. Effective. This ordinance shall become effective up on publication of a summary thereof.

PASSED AND APPROVED this ____ day of _____, 2022.

Zach Robinson, Sandy City Council Chair

ATTEST:

City Recorder

PRESENTED to the Mayor of Sandy City for her approval this ____ day of _____, 2022.

APPROVED this ____ day of _____, 2022.

Monica Zoltanski, Mayor

ATTEST:

City Recorder

PUBLISHED this ____ day of _____, 2022.

Exhibit “A”

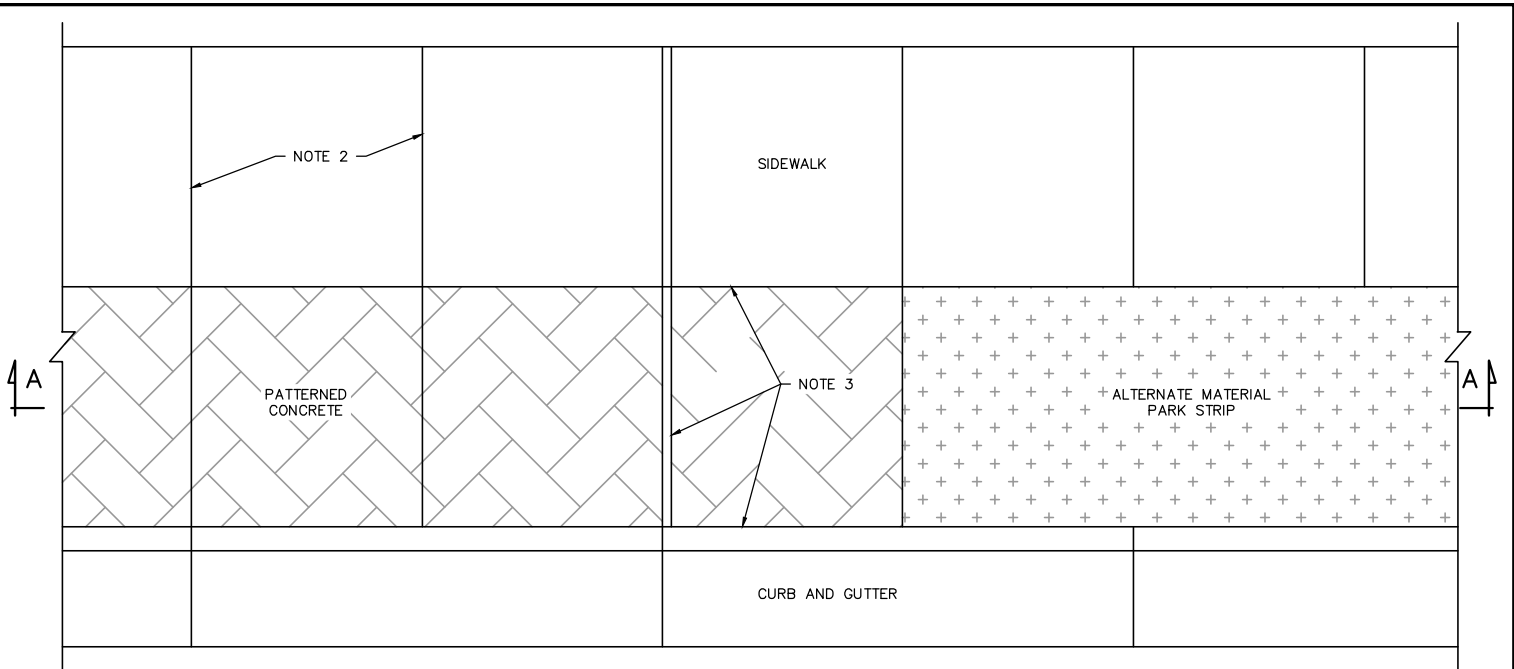

PLAN VIEW

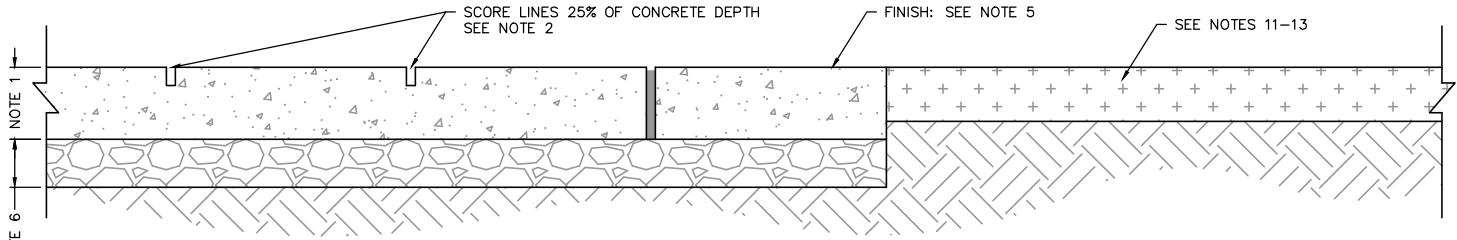

SECTION A-A

GENERAL NOTES

1. USE MONOLITHIC CONSTRUCTION. 4" MINIMUM THICKNESS.
2. PLACE SCORE LINES AT SAME INTERVALS AS ADJACENT SIDEWALK. SEE SECTION 03050.
3. USE 1/2" EXPANSION JOINT FILLER MADE OF PREMOLDED BITUMINOUS OR SIMILAR MATERIAL ALONG THE PERIMETER AND AT ALL OTHER EXPANSION LOCATIONS.
4. EDGE CONCRETE WITH 1/2" RADIUS EDGING TOOL. ROUND EDGES AT EXPANSION JOINTS TO A RADIUS OF 1/2".
5. PATTERN: PLACE UNIFORMLY OVER SURFACE USING RELEASE POWDER ON STAMPING MATS. STAMP TO A DEPTH OF 1/2". CLEAN FUGITIVE RELEASE POWDER FROM CONCRETE PRIOR TO APPLICATION OF CURING COMPOUND.
6. COLORING: APPLY COLOR TO CONCRETE MIX PER MANUFACTURER'S REQUIRED RATIO. NO BROADCASTING OF COLOR ON THE SURFACE OF THE CONCRETE.
7. APPLY SEALING/CURING COMPOUND PER APWA SECTION 03 39 00.
8. USE A MINIMUM OF 4" UNTREATED BASE COURSE COMPACTED TO 96% AVERAGE OF THE MAXIMUM DRY DENSITY. (ASTM D698)
9. THE CLASS OF CONCRETE FOR PATTERNED CONCRETE SHALL BE AA(AE), SEE SECTION 03000.
10. USE OF PATTERNED CONCRETE IN PARK STRIP REQUIRES ENGINEERS APPROVAL AND SHALL BE INSTALLED IN ACCORDANCE WITH APWA STANDARD PLAN 232.
11. ROCK MULCH REQUIRED TO BE 3/8" - 4" ANGULAR CRUSHED, COMPACTED DECORATIVE ROCK WHERE LESS THAN SIX PERCENT (6%) SLOPE AND NOT LOCATED IN CONCENTRATED SURFACE DRAINAGE RUNOFF AREAS.
12. ROCK MULCH 2" - 4" REQUIRED IN SLOPES GREATER THAN SIX PERCENT (6%) SLOPE OR IN CONCENTRATED SURFACE DRAINAGE RUNOFF AREAS.
13. BARK MULCH IS PROHIBITED IN THE PARKSTRIP AREA UNLESS A TWO-FOOT-WIDE BUFFER OF ROCK MULCH ABUTTING THE CURB IS PROVIDED.
14. ALL SECTIONS OF SANDY CITY CODE 21-25-1(4) APPLICABLE FOR PARKSTRIP LANDSCAPING REQUIREMENTS. REFERENCE AND REVIEW PRIOR TO STARTING ANY LANDSCAPE PROJECT.

1	R. KUMP	DWG REVISION	5/24/17
2	R. KUMP	NOTES REVISION	11/1/22
NO.	AUTHORIZED BY	REVISIONS	DATE

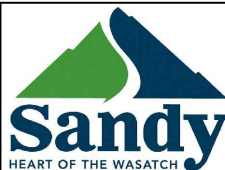

STANDARD DETAIL
PUBLIC WORKS
SW-06
PARKSTRIP DETAILS

DIVISION 7
LANDSCAPING AND IRRIGATION

SECTION 07100

DESIGN STANDARDS

PART 1 GENERAL

1.01 SECTION INCLUDES

- A. Procedures for Landscape and Irrigation Design

1.02 RELATED WORK

- A. Section 07200: Grading for Landscaping
- B. Section 07300 Pressurized Irrigation Systems
- C. Section 07400: Seed, Turf Seed, and Turf Sod
- D. Section 07500: Trees, Shrubs, & Groundcover
- E. Section 07800: Topsoil
- F. Section 01620: Storage and Protection

PART 2 PRODUCTS Not Used

PART 3 EXECUTION

3.01 PROJECT DATA SHEET

Project data sheet shall include the following

- 1. Project name and address
- 2. Landscape Designer/Landscape Architect's name, address, phone and fax number

3.02 PLANTING PLAN

A detailed Planting Plan shall be drawn at a scale (not more than 1"=30') that clearly identifies the following:

- 1. Location of all plant materials, a legend with botanical and common names, quantity, and size of plant materials
- 2. Property lines and street names
- 3. Existing and proposed buildings, walls, fences, light poles, utilities, paved areas and other site improvements
- 4. Existing trees and plant materials to be removed or retained
- 5. Designation of Landscape Zones

3.03 IRRIGATION PLAN

A detailed Irrigation Plan shall be drawn at the same scale as the planting plan and shall contain the following information:

- 1. Layout of the irrigation system and a legend summarizing the type and size of all components of the system, including manufacturer name and model numbers
- 2. Static water pressure in pounds per square inch (psi) at the point of connection to the public water supply
- 3. Flow rate in gallons per minute and design operating pressure in psi for each valve and precipitation rate in inches per hour for each valve with sprinklers.

3.04 GRADING PLAN

A Grading Plan shall be drawn at the same scale as the Planting Plan and shall contain the following information:

1. Property lines and street names, existing and proposed buildings, walls, fences, utilities, paved areas and other site improvements
2. Existing and finished contour lines and spot elevations as necessary for the proposed site improvements

3.05 SOILS REPORT

- A. A Soils Report will be required where irrigated landscaped areas consisting of grass or similar turf exceed 33% of the overall landscaped area. The Soils Report shall describe the depth, composition, and bulk density of the top-soil and subsoil at the site, and shall include recommendations for soil amendments. The Planting Plan shall incorporate the recommendations of the Soils Report into the planting specifications
- B. The soils report shall be acquired during the design phase of projects.

3.06 LANDSCAPE WATER ALLOWANCE

The annual Landscape Water Allowance shall be calculated using the following equation:

$$\text{Landscape Water Allowance} = \text{ETO} \times 1.0 \times 0.62 \times A$$

Where Landscape Water Allowance is in gallons per growing season

- ETO = Reference Evapotranspiration in inches per growing season
1.0 = ETO adjustment factor, 100% of turf grass ETO (growing season adjustment factor)
0.62 = conversion factor
A = total Irrigated Landscape Area in square feet

3.05 IRRIGATION SCHEDULE

A monthly Irrigation Schedule shall be prepared that covers the initial 90-day plant establishment period and the typical long-term use period. This schedule shall consist of a table with the following information for each valve:

1. Plant type (for example, turf, trees, low water use plants)
2. Irrigation type (for example, sprinklers, drip, bubblers)
3. Flow rate in gallons per minute
4. Precipitation rate in inches per hour (sprinklers only)
5. Run times in minutes per day
6. Number of water days per week
7. Cycle time to avoid runoff

3.07 LANDSCAPE DESIGN STANDARDS

A. Plant Selection.

1. Plants selected for landscape zones shall consist of water conserving plants and/or native vegetation plants that are well-suited to the microclimate and soil conditions at the project site. Plants with similar water needs shall be grouped together in landscape zones as much as possible.

2. For projects located at the interface between urban areas and natural open space (non-irrigated), ~~e~~Extra-d~~D~~rought t~~T~~olerant ~~p~~Plants shall be selected that will blend with the native vegetation and are fire resistant or fire retardant. Plants with low fuel volume or high moisture content shall be emphasized. Plants that tend to accumulate excessive amounts of dead wood or debris shall be avoided.

~~3.~~ Areas with slopes greater than ~~30%~~25 percent shall be landscaped with deep-rooting, ~~w~~Water ~~c~~Conserving ~~p~~Plants for erosion control and soil stabilization. Irrigation devices are limited to drip emitters, bubblers or sprinklers with a maximum precipitation rate not to exceed 0.85 inches per hour.

~~3.4.~~ "Unless otherwise specified in these standards, "Plant Selection" requirements shall be consistent with the landscaping design standards of Section 21-25-4 of the land development code."

~~4.~~

B. Mulch.

~~After completion of all plantings, A~~all irrigated non-turf areas shall be covered with a minimum layer of ~~four~~three [3] inches of ~~M~~mulch to retain water, inhibit weed growth, and moderate soil temperature. Non-porous material shall not be placed under the mulch.

C. Soil Preparation.

~~Soil preparation shall be suitable to provide healthy growing conditions for the plants and to encourage water infiltration and penetration.~~ Soil preparation shall include scarifying the soil to a minimum depth of six [6] inches and amending the soil with organic material as per specific recommendations ~~of the landscape designer/landscape architect~~ based on the ~~S~~soils ~~R~~report.

3.08 IRRIGATION DESIGN STANDARDS

~~A.~~ All irrigation shall be appropriate for the designated plant material to achieve the highest water efficiency.

~~A.B.~~ A landscape water meter and backflow prevention assembly for landscaping that ~~are in compliance with~~complies with state code shall be installed after the City meter and outside the City maintained meter box on the customer's service line. The size of the meter shall be determined based on irrigation demand.

~~B.C.~~

~~A.~~ A pressure regulating valve shall be ~~installed in the backflow enclosure upstream of the backflow and shall be set at the appropriate psi rating established by the manufacturer of the installed irrigation components accounting for backflow pressure loss. installed and maintained by the consumer if the static service pressure exceeds 80 pounds per square inch (psi). The pressure regulating valve shall be located between the landscape water meter and the first point of water use, or first point of division in the pipe, and shall be set at the manufacturer's recommended pressure for sprinklers.~~

~~G.D.~~ Automatic Controller

1. All irrigation systems shall include ~~a WeatherTrak Controller an electric automatic controller with multiple program and multiple repeat cycle capabilities and a flexible calendar program.~~

2. All controllers shall be equipped with ~~an~~automatic ~~rain delay or Rain-s~~Shut-off ~~d~~Device ~~capabilities.~~

~~D.E.~~ On slopes exceeding ~~30%~~25 percent, the irrigation system shall consist of ~~d~~Drip

~~e~~Emitters, ~~b~~Bubblers, or sprinklers with a maximum ~~p~~Precipitation ~~r~~Rate of 0.85 inches per hour and adjusted sprinkler cycle to eliminate ~~r~~Runoff.

~~E.F.~~ Each valve shall irrigate a landscape zone with similar site, slope and soil conditions and plant materials with similar watering needs. Turf and non-turf areas shall be irrigated on separate valve(s). In addition, drip emitters and sprinklers shall be placed on separate irrigation valves.

~~F.G.~~ Drip irrigation or bubblers shall be used except in turf areas. Drip ~~e~~Emitters, Netafim tree rings or a ~~b~~Bubbler shall be provided for each tree, where practicable. Bubblers shall not exceed 1.5 gallons per minute per device. Bubblers for trees shall be placed on a separate valve unless specifically exempted by the Sandy City Public Utilities Department due to the limited number of trees on the project site.

~~G.H.~~ Sprinklers shall have matched ~~p~~Precipitation ~~r~~Rates with each control valve circuit.

~~H.I.~~ Check valves shall be required where elevation differences will cause low-head drainage. Pressure compensating valves and sprinklers shall be required where a significant variation in water pressure will occur within the irrigation system due to elevation differences.

~~I.J.~~ ~~PVC~~ Drip Irrigation lines shall be placed underground, ~~poly drip irrigation lines shall be placed on top of soil but below mulch~~ or otherwise permanently covered, except for ~~d~~Drip ~~e~~Emitters and where approved as a temporary installation. Drip irrigation systems shall be equipped with a pressure regulator, flush end assembly, and any other appropriate components. Filters and end flush valves shall be provided as necessary.

~~J.K.~~ Irrigation zones with overhead spray or stream sprinklers shall be designed to operate between 11:00 p.m. and 6:00 a.m. to reduce water loss from wind and evaporation. Drip or bubbler zones are excluded.

~~K.L.~~ Program valves for multiple repeat cycles where necessary to reduce runoff, particularly slopes and soils with slow infiltration rates.

3.09 PLAN REVIEW

As part of the Plan Approval Process, a copy of the above information shall be submitted to the City for review and approval before construction begins. All Landscape plans submitted must be certified by a licensed Landscape Architect or approved Landscape Designer. The Irrigation Plans submitted must be certified by an approved Irrigation Designer or a Landscape Architect.

END OF SECTION

SECTION 07200
GRADING FOR LANDSCAPES

PART 1 GENERAL

1.01 SECTION INCLUDES

Materials and procedures for landscape grading.

1.02 RELATED WORK

- A. Section 02230: Granular Material, Flowable Fill & Topsoil
- B. Section 07800: Topsoil
- C. Section 01620: Storage and Protection

1.02 QUALITY ASSURANCE

Landscape grading is aesthetic by nature and subject to continual monitoring and modification during backfilling. Work closely with Engineer particularly when grading and constructing berms, channels, or other aesthetic structures.

PART 2 PRODUCTS

1.01 BACKFILL MATERIALS

- A. For fill areas which are to be landscaped, provide soils which comply with Section 02230.
- B. Topsoil: Refer to Section 07800.

PART 3 EXECUTION

3.01 PREPARATION

Identify required line, levels, contours, and datum.

3.02 PROTECTION

Protect existing trees, shrubs, lawns, existing structures, fences, roads, sidewalks, paving, curb and gutter, and other features. Refer to Section 07900

3.03 CLEANING

- A. Remove stockpiles from the site. Grade site surface to prevent free standing surface water.
- B. Leave borrow areas clean and neat.

END OF SECTION

SECTION 07300

PRESSURIZED IRRIGATION SYSTEMS

PART 1 GENERAL

1.01 SECTION INCLUDES

Aboveground, underground, and drip irrigation systems complete with heads, valves, controls, and accessories.

1.02 RELATED SECTIONS

- A. Section 07600 - Vegetation Establishment Period.
- B. Section 03000 - Concrete Work.
- C. Section 03100 - Concrete Formwork
- D. Section 03200 - Concrete Reinforcement

1.3 REFERENCES

- A. ASTM A 53: Pipe, Steel, Black, and Hot-Dipped, Zinc-Coated, Welded and Seamless.
- B. ASTM B 88: Copper Pipe.
- C. ASTM B 687: Brass, Copper, and Chromium-Plated Pipe Nipples.
- D. ASTM D 1784: Rigid Poly(Vinyl Chloride) (PVC) Compounds and Chlorinated poly (Vinyl Chloride) (CPVC) Compounds.
- E. ASTM D 1785: Poly(Vinyl Chloride) PVC Plastic Pipe, Schedules 40, 80, and 120.
- F. ASTM D 2466 and D 2464: Poly(Vinyl Chloride) (PVC) Plastic Pipe Fittings; Schedules 40 and 80.
- G. ASTM D 2564: Solvent Cements for Poly(Vinyl Chloride) (PVC) Plastic Piping Systems.
- H. ASTM D 2672: Joints for IPS PVC Pipe Using Solvent Cement.
- I. ASTM F 656: Primers for Use in Solvent Cement Joints of Poly(Vinyl Chloride) (PVC) Plastic Pipe and Fittings.
- J. ASSE 1013, 1015: Backflow Preventers, Pressure Reducers.
- K. NEC: National Electric Code. (Latest edition)
- L. Utah Plumbing Code: Section 1003.
- M. Detail MC-01: 2" or Less Mainline Connection
- N. Detail MC-02: Larger than 2" Mainline Connection
- O. Detail IV-01: Valve Assembly
- P. Detail IV-02: Valve Manifold
- Q. Detail IV-03: Drip Irrigation Valve
- R. Detail IV-04: Quick Coupler Valve
- S. Detail IR-01: Typical Sleeving Detail
- T. Detail IR-02: Sleeving Diagram
- U. Detail IR-03: Trench Detail
- V. Detail IR-04: Pop-Up Spray Head
- W. Detail IR-05: Pop-Up Rotor Head
- X. Detail IR-06: PVC to Poly Pipe Connection
- Y. Detail IR-07: Emitter into Poly-Tube

- Z. Detail IR-08: Pedestal with Controller
- ~~AA.~~ Detail IR-09: Wall Mount Controller
- ~~AA.BB.~~ Detail IR-10: Wire Splice Detail
- ~~BB.CC.~~ Detail IR-11: Mini-click Detail

1.04 PERFORMANCE REQUIREMENTS

- A. Contractor shall provide documentation of the following:
 - 1. Contractor is licensed to perform landscape construction in the state of Utah.
 - 2. Contractor has been installing Sprinklers on commercial projects for ten previous years and has five projects of similar size as references.
 - 3. On site supervisor has five consecutive years of commercial irrigation installation experience. He or She shall be a current Certified Irrigation Contractor in good standing with the Irrigation Association. They must be on the project 85% of each working day.
 - 4. All laborers installing sprinkler must have the following certifications and carry them on the project at all times.
 - a. Training from IPS factory for Glue.
 - b. Training form Page Wire for wire install, wire connecting and grounding equipment
- B. Location of sprinkler heads: Design location is approximate.
 - 1. Adjust as necessary to avoid existing plants and other obstructions.
 - 2. At no time should the number of heads or valves for example be less than that indicated on the plans.
- C. Water Coverage:
 - 1. Head to head coverage in turf and other planting areas (100 percent).
 - 2. Do not increase or decrease number of heads or size of pipe indicated unless approved by Engineer.
 - 3. Meet the following Distribution Uniformity as determined through an irrigation audit pre-formed by an independent IA (Irrigation Association) certified Landscape Irrigation Auditor following IA Audit guidelines available from the Irrigation Association.
 - a. Spray Heads – 60%
 - b. Rotor Heads – 70%
- D. PVC Pipe: Must be stamped with certified NFS.
- E. If work is to continue after November 1 or resume before April 15, drain the system at the end of each work day. Do not permit water to remain in pipe overnight unless otherwise approved by the Parks Superintendent.
- F. Verify and have marked the location of all utilities and underground obstructions.

1.05 DEFINITIONS

- A. Mainline: The system of pipes that carry water from the Point of Connection (POC) to the valves.
- B. Lateral Lines: The system of pipes that carry water from the valves to the sprinkler heads and/or emitters.

1.06 SUBMITTALS

- A. Product Data: Manufacturer's technical data and installation instructions.
- B. Certificates of compliance to Engineer prior to installation.
- C. As-Built Drawings: Red-lined plan layout and details illustrating mainline and lateral lines location, size, and assembly. Include type and coverage of heads, wire runs not contained in mainline pipe trench, type of valves, controllers, fittings and accessories.
- D. Operating and Maintenance Data:
 - 1. Instructions covering full operation, care, and maintenance of system (an controls) and manufacturers parts catalog. Include drain procedures, blow out features for example.
 - 2. Instruct maintenance personnel in proper adjustment of sprinkler heads and use of special tools for adjustments.
- E. Keys:
 - 1. Gate Valve Key.
 - 2. Stop and Waste Valve Key: T-handle, rigid steel, 5 ft long minimum, key end to fit the stop and waste valve nut.
 - 3. Quick Coupler Valve Key Rainbird 44K or Hunter HK-44 and

shall have hose swivel PART 2 PRODUCTS

2.01 PIPE AND FITTINGS

- A. Mainline: Solvent welded schedule 40 PVC through 4 inch, then Class 200 PVC. ASTM D 1784 and ASTM D 1785.
- B. Lateral line: Solvent welded schedule 40 PVC up to 2-1/2", anything above 2-1/2" shall be Class 200 PVC. Meet ASTM 1784 and ASTM D 1785.
- C. Pipe Fittings:
 - 1. Lateral Line: Solvent welded schedule 40 PVC up to 2-1/2", anything above 2-1/2" shall be Solvent welded schedule 80 PVC . Meet ASTM D 2466.
 - 2. Main Line:
 - a. Solvent welded schedule 80 PVC. Meet ASTM D 2466.
 - b. Harco cast Iron or approved equivalent.
 - c. All cast iron fittings installed with joint restraints and/or thrust blocks.
- D. Valve Fittings: Schedule 80 Manifold system
- E. Risers: Threaded schedule 80 PVC. Meet ASTM D 2464.
- F. Copper Pipe: Type K as specified in ASTM B 88.
- G. Copper Fittings: Wrought or cast as specified in ASTM B 687.

- H. Poly and Vinyl Pipe
1. Poly Irrigation Tubing conforming to the following sizes:

Size	ID	OD
1/2"	0.600	0.700
5/8"	0.720	0.830
3/4"	0.830	0.940
1"	1.060	1.200
1-1/2"	1.390	1.550
 2. 1/4" Vinyl Distribution tubing with an ID of .16" and an OD of .22"
- I. Poly Pipe fittings: Compression, Barbor Spin LOC sleeve feedings as recommended by poly pipe manufacture.

2.02 VALVES

- A. Automatic Control Valve - For inventory control purposes use only the following models of Automatic Control Valves in there appropriate application:
~~1. Rainbird: PEB, PESB, 300BPE, 300BPES, XCZ-100 COM and/or XCZ-LF-100 PRF.~~
2.1. Hunter ICV, Hunter Drip ICV-101 or Low Flow PCz-10140 or approved equivalent.
- B. Master Valves - follow section 2.02 A. for master valves 3 inch or smaller. For Master Valves larger than 3 inches consult Parks Superintendent.
- C. Gate Valve - Resilient wedge: Milwaukee series 105 or equivalent, 200 psi rated (minimum) and sized according to main line.
- D. Ball Valve - Apollo or approved equal that is brass, 200 psi rated (minimum), sized according to main line and domestically made.
- E. Quick Coupler Valve - For inventory control purposes use only the Rainbird 44RC or Hunter HQ-44RC .
- F. Pressure Regulator - Use Wilkins Model 600xl or 600xlhr ~~500 or 500FC~~ or approved equal.

2.3 BACKFLOW PREVENTER

- A. Body and caps constructed of bronze with wear and corrosion resistant internal parts complete with bronze quarter turn ball valves.
- B. Reduced Pressure Principle Device (RP) as specified in ASSE 1013.
- C. Capable of being tested and serviced without removal of device from the line.

2.4 AUTOMATIC CONTROLLER

- ~~A. General: A commercial grade controller manufactured expressly for control of automatic valves and underground irrigation systems and equipped with the following minimum features:~~
- ~~1. 12-hour duration for any or all stations.~~
 - ~~2. Four programs, with eight start times each.~~
 - ~~3. Two master valve terminals, one programmable by station.~~

- ~~4. 365-day calendar with leap-year intelligence.~~
- ~~5. Event day off option.~~
- ~~6. Programmable rain delay.~~
- ~~7. Water budget by program with adjustments from 0 to 300 percent in one percent increments.~~
- ~~8. Capable of having total run time split into usable cycles.~~
- ~~9. Station timing: 0 to 12 hours for all stations (0 to 16 hours with water budget at 300 percent); 0 to 120 minutes selectable in 1-minute increments; above 120 minutes selectable in 10-minute increments~~
- ~~10. Manual or automatic operation.~~
- ~~11. Non-volatile.~~
- ~~12. Battery backup.~~
- ~~13. Heavy-duty electrical surge protection.~~
- ~~14. UL listed; GSA, CE approved~~

~~B.A. On sites one acre or larger Use a Rainbird MAXI Com Weather track controller - Consult with Parks Superintendent for specifics~~

~~C.B. Transformer: Capable of converting service voltage to control voltage in accordance with manufacturer's recommendations.~~

~~D.C. Controller is to be installed on a dedicated electrical circuit - 15 amp minimum.~~

2.5 PEDESTAL

Free-standing stainless steel unit typically specified for the controller. Hardware included.

2.6 SPRINKLER HEADS

A Fixed Riser

1. ½ inch x 24 inch schedule 80 riser Male Pipe Threads (MPT).
2. ½ inch shrub head adaptor Female Pipe Threads (FPT) x MPT.
3. ½ inch FPT barbed swing pipe adapter.

B Pop-up Spray Head - For inventory control purposes use only the following models with a minimum pop up height of 6 inches:

- ~~1. Rainbird 1800 Series PRS. Rainbird 1806SamPRS~~
- ~~2. Hunter Pro-Spray PR-30~~
- ~~4.3. Hunter Pro-Spray PR-40 if using MP Rotary Nozzles. Toro 570 Z.~~

C Rotary Head - For inventory control purposes use only the following models of Pop-up Rotor Heads

1. Rainbird
2. Hunter
3. Toro
4. Heads must include the following:
 - a. 5-inch minimum pop-up with water-lubricated gear driven design.
 - b. Integral rubber cover. - Purple if using non-potable water
 - ~~c. Built-in check valve.~~

~~4.5. All MPR nozzles need to be Hunter~~

D Pop-up Impact Head - Not allowed in Sandy Parks

E Above-ground Impact - Not allowed in Sandy Parks

2.7 PLASTIC NOZZLES

- A. Fixed Spray - use same manufacture as pop-up body
 - 1. Radius patterns and gal/min as shown on plans.
 - 2. Matched precipitation rates.
 - 3. Stainless steel adjustment screw.
 - 4. FPT to match 1/2 inch shrub head adapter.
 - 5. Pressure regulating: (Required on all fixed spray heads.)
 - 6. Filter screen.

- B. Bubbler - use same manufacture as pop-up body
 - 1. Made of high-impact plastic.
 - 2. Pressure compensating with adjustable flow and radius as shown on plans.
 - 3. 2 inch FPT.
 - 4. Attach to fixed riser or pop-up spray.
 - 5. Filter screen.

2.8 DRIP TUBING

- A. Self-cleaning, pressure compensating, polyethylene dripper line.

- B. Dripper discharge: ~~0.4 0.6~~ gal/hr to 0.9 gal/hr and choice of 12 inch, 18 inch, or 24 inch spacing.

- C. Pressure compensation range from 8 psi to 60 psi.

- D. 0.63 inch (16.1 mm) outside diameter; 0.54 inch (13.6 mm) inside diameter.

2.9 INDIVIDUAL DRIP EMITTERS - For inventory control purposes use only the following models of drip emitters

- A. Rainbird - XB pressure compensating emitters
 - TS-025 tubing stake
 - DBC-025 bug cap. Install flush cap at end of line in 10 inch round valve box.

2.10 LINE FLUSHING VALVE

- A. Made of high impact plastic.

- B. Maximum flow rate per flush valve: 15 gal/min.

- C. Automatic cleaning operation.

- D. Can be disassembled allowing for winterization blow-out.

- E. 1/2 inch MPT threads.

2.11 AIR/VACUUM RELIEF VALVE

- A. Brass body and cap and rated to 200 psi.

- B. Temperature resistant silicone disc seat.

2.12 Y FILTER

Part of the ~~Hunter ICZ-101XCZ-100-COM~~ assembly for flow rates of 3-20 GPM or the ~~Hunter PCZ-101 XCZ-LF-100-PRF~~ assembly for flow rates of 0.2-3 GPM.

2.13 SWING PIPE

- A. Flexible Polyethylene Pipe: Maximum flow 6.0 gal/min. Inside diameter of 1/2 inch (.490 inch) with a wall thickness of 6/32 inch (.200 inch) and 80 psi rated excluding rotors.
- B. Pre-fab swing pipe: For flows exceeding 6 gal/min or attached to quick coupler. As manufactured by Lasco or approved equivalent .
- C. 1/2 or 3/4 inch Barbed Male Elbow: Plastic
- D. 1/2 or 3/4 inch Street Elbow: Marlex

2.14 VALVE BOX

Precast plastic with adequate hand room to operate small tools and provisions for locking cover to frame.

2.15 WIRE

- A. Provide wire for connecting remote control valves to the automatic controllers that is Type "PE", 600 V, stranded or solid copper, single conductor wire with PE insulation and bearing UL approval for direct underground burial feeder cable. Page wire P7079D or equal.
 - 1. Make all connections with UL approved type seal to make a waterproof connection.
 - 2. Where possible, bury wires in the same trench as the pipe.
- B. Provide wire with 0.045 inches insulation
 - 1. For wire sizes 14, 12, 10, and 8 use a single conductor solid copper wire, and for sizes 6 and 4 use stranded copper wire.
 - 2. Make control or "hot" wires red, common or "ground" wires white, "spare" wires orange and "tracer" wires yellow.
- C. Tape wire to main line every 10 feet.
- D. Provide 18 inch minimum wire loop at all changes of direction and 30 inches inside each valve box.
- E. Provide a separate common and tracer wire for each controller; and provide one spare wire for every 10 valves with a maximum of 10 spares.
- F. All wires not taped to the mainline must be installed in a conduit.

2.16 QUICK COUPLER - For inventory control purposes use only the following models

- A. Rainbird 44RC or Hunter HQ-44RC
- B. Install in a 10 inch round valve box, minimum
- C. Rainbird 44K or Hunter HK-44 - 1 inch brass valve key.
- D. Rainbird SH-1 3/4 inch brass swivel hose ell.

2.17 WASHED AGGREGATE

1-1/2 inch maximum with 100 percent retained on a No. 4 sieve.

2.18 JOINT PRIMER AND SOLVENT CEMENT

Weldon P-70 & 711 or approved equivalent.

2.19 ACCESS SLEEVE

2 inch, Schedule 40 PVC with a yellow plastic snug cap Aspen Earth AE-(2)SC or approved equal.

2.20 TEFLON TAPE

For use on threaded joints. Quality grade, 0.004 inch and domestically made.

2.21 CONCRETE THRUST BLOCKS

- A. Thrust blocks shall be provided as required. They shall be placed between undisturbed soil and the fitting to be anchored. The area of bearing on the pipe and on the ground in each instance shall be that shown on the drawings. The block shall, unless otherwise shown or directed, be so located as to contain the resultant thrust force so that the pipe and fitting joints will be accessible for repair.
- B. Concrete for thrust blocks shall have a compressive strength of not less than 2500 psi in 28 days.
- C. Care should be taken not to pour concrete around bolts and wires.
- D. Wrap irrigation pipe with a poly wrap before pouring thrust block.

PART 3 EXECUTION

3.1 EXCAVATION

- A. Stake pipe and sprinkler locations for approval.
- B. Excavate trenches for sprinkler system pipe to provide 18-24 inches of cover over main lines and 12-18 inches over lateral lines. Where trenching is required in proximity to trees that are to remain, refer to Section 07900.
- C. Barricade trenches within the clear zone and along pedestrian routes that are left open overnight.

3.2 INSTALLATION

- A. General: Plans are diagrammatic. Proceed with installation in accordance with the following:
1. Install stop and waste valves, backflow preventers and other equipment required by local authorities according to Utah Laws and Regulations to make system complete.
 2. Install main line, automatic control valves, lateral lines, fittings, and heads/drip line as specified.
 3. Thoroughly flush main lines before installing automatic control valves, and laterals before installing sprinklers. Flush supply lines thoroughly before installing backflow preventers or other regulating devices.
 4. After completion of grading, seeding or sodding, and rolling of grass areas, adjust heads to be plumb and flush with finished grades (flush is even with top of soil level or top of material level).
- B. Piping: Assemble all mainline and lateral lines in accordance with manufacturer's recommendations with no cul-de-sacs. Install PVC pipe in dry weather above 40 degrees F as specified by manufacturer's recommendations. Allow joints to cure a minimum of 8 hours before testing.
- C. Sleeving: Coordinate sleeving installation before placing pavement.
- D. Control Valves: Install at plan locations and according to detail. Use Schedule 80 PVC pipe for nipples on valve header, length as necessary. Install valves two maximum per each jumbo, plastic valve box and provide 30 inches of expansion loop slack wire at all connections inside valve box. Refer to Standard Detail IV-02.
- E. Manual or Automatic Drains: **NOT ALLOWED** Except between Back Flow and Water Meter.
- F. Quick-Coupling Valves: Install using 1 inch Brass insert swing joint~~Schedule 80-PVC nipples for risers and elbows~~. Locations as indicated on plans and at every valve complex.
- G. Back-flow Preventers: Install assembly using the details.
- H. Valve Access Boxes:
1. Install over all automatic control valves, manual control valves, or zone shutoff valves and sized to provide adequate room for maintenance.
 2. Install valve boxes flush with finish grade and place parallel or perpendicular to adjacent curbs, sidewalks, or driveways.
 3. Imprint a valve control number on each valve box cover that corresponds to the valve controller (clock). Print the valve box number one inch high (minimum) in a permanent and legible manner.
 4. Place washed 1 ½ inch aggregate in sump as shown on details.
- I. Automatic Controller:
1. Stake or mark controller location for approval.
 2. Mount the panel enclosure so adjustments can be conveniently made by the operator.
 3. Properly ground controller in accordance with Utah Laws and Regulations
 4. Install lightning arrestor on the incoming power right before the transformer of the irrigation controller.
 5. Make all control wire connections to automatic controllers.

| Sandy City Corporation - Rev. 10/22

3.6. Coordinate controller installation with electrical work.

4.7. If pedestal controller is used, pour the concrete pedestal base with inserted

**SANDY CITY SPECIFICATIONS AND STANDARD DETAILS
GENERAL CONDITIONS – DEVELOPMENT**

PART 7.0 B PUBLIC UTILITIES DEVELOPMENT
STANDARDS AND REQUIREMENTS

PART 7.0 B PUBLIC UTILITIES DEVELOPMENT STANDARDS AND REQUIREMENTS

7.01 GENERAL

- A. It is anticipated that when all requirements of the Sandy City Public Utilities Department have been met, a Public Utilities Final Review and Approval Letter will be issued. Signing of this letter by the Developer or his/her representative is required. This letter serves as a water availability letter, which is required by the Salt Lake County Board of Health.
- B. Drawing/drawings, signed, as approved by the City and the Developer will be issued for use by the Developer and Contractor.
- C. The following must be completed prior to holding a pre-construction meeting and beginning construction work on the site:
 - 1. Plans approved.
 - 2. Signing of the Public Utilities Final Review and Approval Letter.
 - 3. Storm Water Pollution Prevention Plan and Post-Construction Storm Water Maintenance Agreement approved if required.
 - 4. Utility line-work (in AutoCAD or GIS format) received from the Developer.
 - 5. Payment of fees.
 - 6. Posting of a bond.
- D. A pre-construction meeting is required once final approval has been granted. The pre-construction meeting shall be scheduled through Sandy City Public Works Department.
- E. All current Sandy City standards and specifications, State rules and regulations, ordinances, policies, and fees pertaining to the development shall be adhered to, including improvements in Public right-of-way and on private property.
- F. Additional requirements may be required for the project beyond those identified herein.

7.02 DRAWINGS

- A. Drawings shall be submitted electronically 24" x 36" in paper scale for review and approval of the Sandy City Public Utilities Department.
- B. All final drawings and calculations shall be stamped, signed, and dated by a licensed Professional Engineer, licensed to practice in the State of Utah.
- C. All landscape drawings shall be stamped, signed, and dated by a licensed Architect.
- D. The location of all existing and proposed utility lines shall be shown on the drawings. Adequate separation from existing utilities shall be provided to meet the requirements of utility line owners.
- E. The following information shall be provided for existing and proposed utilities:
 - 1. Size and material of water lines.
 - 2. Size and location of meters, valves, fire hydrants, blowoffs, vaults, etc. relating to the water system.
 - 3. Size, slope, and material of storm drain and irrigation pipes.
 - 4. Top of lid/grate and flow line elevations of storm drain and irrigation structures.
 - 5. Type and location of streetlights, junction boxes, and electrical wiring. Power

source shall be determined during construction.

6. Irrigation system details for irrigation boxes, head walls, head gates, and grates.
- F. The following note shall be added to the Plat and Grading and Drainage Plan for residential subdivisions and individual residential lots:
1. No driveway shall be constructed to convey storm water runoff toward any building.
 2. Each residential lot is required to retain storm water on site, except for the portion of the lot that drains toward the street and/or to subdivision storm water flow control feature(s) as long as the downstream storm water system can accommodate the flows, during and after construction. This can be accomplished by use of swales, retention areas, berms, planter beds, underground infiltration, etc.
 3. Properties are to be graded such that storm water runoff will drain away from structures and towards property boundaries. However, new development or redevelopment shall not increase the burden of storm water on neighboring and/or downstream properties. Storm water runoff shall be entirely controlled within the limits of project site. Perpetrating property owners may be liable for damages in civil courts due to damages caused to adjacent properties from runoff (including flows that existed before the new development or redevelopment occurred). Any concentrated flows leaving a site shall have an agreement/easement with the affected property owners.
- G. The following shall be added to the Plat and Grading and Drainage Plan for commercial projects or projects with a Homeowner Association (HOA):
1. Volume of detention/retention.
 2. Note: For Storm Water Maintenance, refer to Post-Construction Storm Water Maintenance Agreement for maintenance of storm water system.
- H. Drainage structures (inlets, combo boxes, junction boxes, and pipe to structure collar) on the drawings, shall reference the Sandy City Standard Detail as listed below (e.g. Single Curb Inlet Box per SW-02):
1. Single Curb Inlet Box: SD-02.
 2. Double Curb Inlet Box: SD-03.
 3. Combo Box: SD-04 A/B.
 4. Junction Box: SD-05 A/B.
 5. Pipe to Structure Collar: SD-06.
- I. The location of existing water, storm water, and irrigation easements shall be shown on the drawings.

7.03 NOTES TO BE ADDED TO DRAWING(S)

A. WATER NOTES (to be added to the Utility Plan)

1. Notify Sandy City Public Utilities Inspector (801-568-7280), at least one business day (24 hours) prior to beginning construction.
2. A pre-construction meeting is required once final approval has been granted. The pre-construction meeting shall be scheduled through Sandy City Public Works Department.

3. All construction shall conform to the latest revision of the Sandy City Standard Specifications and Details for Municipal Construction and/or other requirements as set forth in the Public Utilities Final Review and Approval Letter established for the development. Specifications and details can be obtained on the Sandy City website.
 4. Submittals are required to be approved by the Engineer for all bedding, backfill, pipe, meters, boxes, vaults, valves, fire hydrants, blowoffs, vaults, etc. relating to the water system. Submittals must have sufficient information to show that the proposed items conform to Sandy City standards and specifications.
 5. Construction work shall be conducted in accordance with the Utah Pollution Discharge Elimination System (UPDES) regulations.
 6. Water lines shall be installed 4-feet off lip of gutter on the north and/or east side of roadway. Water lines shall not be installed within or through parking stalls or under concrete pavement, unless water line is to be maintained by private property owner.
 7. A minimum of 48-inches and a maximum 60-inches of cover from the top of the pipe to the finish grade is required.
 8. For construction east of the Utah Transit Authority's TRAX line, use Ductile Iron Pipe, use thickness Class 52 or better.
 9. For construction west of Utah Transit Authority's TRAX line, use Polyvinyl Chloride (PVC) Pipe, use class DR-14 or better. 10 gauge wire shall be placed on top of the pipe (per Sandy City specifications) for future relocation. No deflection in pipe joints will be allowed on PVC pipes.
 10. All mechanical joints must be restrained using mega lugs for DIP and ROMAC grip rings for PVC or approved equal. Mega lugs shall not be allowed on PVC pipe.
 11. Use 6-inch compression type hydrant by Mueller Centurion or Clow Medallion. Existing hydrants required for fire protection that do not meet current standards shall be upgraded to meet current Sandy City standards and specifications.
 12. When the distance from the water main to the fire hydrant is greater than 6-feet, an additional auxiliary valve shall be flanged to the fire hydrant.
 13. All dead ends shall be plugged with a 2-inch washout or end with a fire hydrant.
 14. All ductile iron water lines, fittings, and valves shall be poly-bagged in accordance with Sandy City standards and specifications.
 15. All water lines shall be bedded with sand (6-inches minimum below and 12-inches minimum on each side and on top of the pipe).
- B. STORM WATER NOTES (to be added to the Grading and Drainage Plan)
1. Notify Sandy City Public Utilities Inspector (801-568-7280), at least one business day (24 hours) prior to beginning construction.
 2. A pre-construction meeting is required once final approval has been granted. The pre-construction meeting shall be scheduled through Sandy City Public Works Department.

3. All construction shall conform to the latest revision of the Sandy City Standard Specifications and Details for Municipal Construction and/or other requirements as set forth in the Public Utilities Final Review and Approval Letter established for the development. Specifications and details can be obtained on the Sandy City website.
4. Submittals are required to be approved by the Engineer for all bedding, backfill, pipe, and structures (inlet boxes, combo boxes, and junction boxes). Submittals must have sufficient information to show that the proposed items conform to Sandy City standards and specifications.
5. Construction work shall be conducted in accordance with the Utah Pollution Discharge Elimination System (UPDES) regulations.
6. All materials and work done in UDOT right-of-way shall conform to UDOT standards and specifications (delete if not applicable).
7. Non-shrink grout shall be used wherever grout is required for the storm drain facilities.
8. Cut pipes off flush with the inside wall of the box or manhole and grout at connection of pipe to box to a smooth finish. Additionally, all jagged or sharp edges at pipe connections are to be removed and grouted smooth.
9. Grout between grade rings. For each inlet box that is located next to a curb, the curb and gutter Contractor is responsible to remove all protruding, jagged or sharp concrete edges and to grout between bottom of inlet lid frame and top of concrete box. Grout to create a smooth, beveled transition at all edges in clean out and inlet boxes. Grout around all edges of the restrictive orifice plate.
10. Remove snap ties, nails, rebar and other protrusions from the box or pipe inside surface, as well as all form work, plastic and cardboard.
11. Silt and debris are to be cleaned out of all inlet boxes, combo boxes, junction boxes, and pipe. The boxes and pipes are to be maintained in a clean condition until after the final bond release inspection.
12. Clean off all manhole lids and inlet grates of asphalt, concrete, tar or other adhesives to allow access.
13. Where a sump is required, the Sandy City Public Utilities Inspector shall be contacted prior to construction to provide an opportunity to check the volume of gravel and gravel gradation.
14. Signs must be posted near each inlet box located in a drinking water recharge zone, with the following words "WARNING THIS IS A DRINKING WATER AQUIFER RECHARGE AREA. DISPOSAL OF ANY WASTE MATERIALS IN THE STORM WATER IS STRICTLY PROHIBITED."
15. All inlet, combo and junction boxes shall be placed on 12-inch (min.) compacted stabilization material.
16. A video of all pipes must be completed before the 80% or 90% bond release and again before final bond release.

17. A representative of the manufacturer or supplier shall be on site during installation of oil/water separator, mechanical treatment devices, media filters, and underground detention/retention systems. The manufacturer or supplier shall provide a letter stating that the system was installed per manufacturer's specifications. If it is unknown whether a representative is required to be present during installation, contact the Sandy City Public Utilities Inspector.
18. A stamped "Letter of Conformance" from the Design Engineer is required to be submitted to Sandy City Public Utilities Department, prior to 90% bond release, stating that storm water flow control elements and storm water treatment facilities (e.g. detention, retention, LID Best Management Practices, oil-water separators, sumps, etc.) were constructed according to the approved plans.

C. STREETLIGHT NOTES (to be added to the Utility Plan)

1. Notify Sandy City Public Utilities Inspector (801-568-7280), at least one business day (24 hours) prior to beginning construction.
2. The Developer is required to grant to the City a minimum of 15-foot wide streetlight easement (7.5-feet each side of pipe) for conduit and wires to the power source on private property.
3. A pre-construction meeting is required once final approval has been granted. The pre-construction meeting shall be scheduled through Sandy City Public Works Department.
4. All construction shall conform to the latest revision of the Sandy City Standard Specifications and Details for Municipal Construction and/or other requirements as set forth in the Public Utilities Final Review and Approval Letter established for the development. Specifications and details can be obtained on the Sandy City website.
5. Submittals are required to be approved by the Engineer for streetlights, junction boxes, and electrical wiring. Submittals must have sufficient information to show that the proposed items conform to Sandy City standards and specifications.
6. Installations shall be located as indicated on the approved plans for the project. Field modifications must be approved by the Sandy City Public Utilities Inspector.
7. Street light poles shall be installed in a manner that will not hinder the operation of fire hydrants, underground water system isolation valves, and other utilities.
8. Installations within close proximity to trees shall be avoided unless approved by Sandy City Public Utilities Inspector.
9. Overhead power lines for streetlights are not allowed.

D. IRRIGATION/LANDSCAPE NOTES (to be added to the Irrigation/Landscape Plan)

1. Mulch: After completion of all planting, all ~~irrigated~~ non-turf areas, including parkstrips, shall be covered with a minimum layer of ~~four~~three (34) inches of mulch to retain water, inhibit weed growth, and moderate soil temperature. Non-porous material shall not be placed under the mulch. ~~4-inch mulch in all irrigated non-turf areas. If rock mulch, minimum is 3-inch.~~ Bark mulch is not allowed in park-strips. Landscape areas that are less than six percent slope and not located in concentrated surface drainage runoff areas can be 3/8 inch to four-inch angular crushed decorative rock that is compacted to stay in place. Landscape areas over

six percent slope or in concentrated surface drainage runoff areas must be two-inch to four-inch rock mulch.

2. All irrigation shall be appropriate for the designated plant material to achieve the highest water efficiency.
- 4.3. Landscape Water Meter: A water meter and backflow prevention assembly that are in compliance with state code shall be installed for landscape irrigation systems after the city meter and outside the city-maintained meter box on the customer's service line., and ~~T~~the landscape water meter and backflow prevention assembly shall be separate from the water meter and backflow prevention assembly installed for indoor uses. The size of the meter shall be determined based on irrigation demand.
- 2.4. Pressure Regulation: A pressure regulating valve shall be installed and maintained by the consumer if the static service pressure exceeds 80 pounds per square inch (psi). The pressure-regulating valve shall be located between the landscape water meter and the first point of water use, or first point of division in the pipe, and shall be set at the manufacturer's recommended pressure for sprinklers.
- 3.5. Automatic controller: All irrigation systems shall include a WaterSense labeled smart controller which automatically adjusts the frequency and/or duration of irrigation events in response to changing weather conditions. ~~an electric automatic controller with multiple program and multiple repeat cycle capabilities and a flexible calendar program.~~ All controllers shall be equipped with ~~an~~ automatic rain delay or Rain sShut-off Device capabilities.
- 4.6. On slopes exceeding ~~30%~~ 25 percent the irrigation system shall consist of ~~d~~ Drip e Emitters, b Bubblers, or sprinklers with a maximum p Precipitation r Rate of 0.85 inches per hour and adjusted sprinkler cycle to eliminate Runoff.
- 5.7. Each valve shall irrigate a landscape with similar site, slope and soil conditions, and plant materials with similar watering needs. Turf and non-turf areas shall be irrigated on separate valves. In addition, drip emitters and sprinklers shall be placed on separate irrigation valves.
- 6.8. Drip irrigation or bubblers shall be used except in turf areas. Drip e Emitters or a b Bubbler shall be provided for each tree, where practicable. Bubblers shall not exceed 1.5 gallons per minute per device. Bubblers for trees shall be on separate valve unless specifically exempted by Sandy City Public Utilities due to the limited number of trees on the project site.
- 7.9. Sprinklers shall have matched p Precipitation r Rates with each control valve circuit.
- 8.10. Check valves shall be required where elevation differences will cause low-head drainage. Pressure compensating valves and sprinklers shall be required where a significant variation in water pressure will occur within the irrigation system due to elevation differences.
- 9.11. Drip irrigation lines shall be placed underground or otherwise permanently covered, except for ~~d~~ Drip emitters and where approved as a temporary installation. Drip irrigation systems shall be equipped with a pressure regulator, flush end assembly, and any other appropriate components. ~~Filters and end flush valves shall be provided as necessary.~~
- 10.12. Irrigation zones with overhead spray or stream sprinklers shall be designed to operate between 6:00 p.m. and 10:00 a.m. to reduce water loss from wind and

evaporation. This would exclude drip or bubbler zones.

- ~~44.13.~~ Program valves for multiple repeat cycles where necessary to reduce runoff, particularly slopes and soils with slow infiltration rates.

Following construction and prior to release of the secondary bond guarantee posted for the project, a Water Use Efficiency Review will be conducted by a Landscape Irrigation Auditor. The auditor shall be independent of the Contractor, Design Engineer, and Developer/Project Owner. The water performance audit will verify that the irrigation system complies with the minimum standards required by Sandy City ordinance. The minimum efficiency required for the irrigation system is

60% for distribution efficiency for all fixed spray systems and 70% distribution efficiency for all rotor systems. The auditor shall furnish a certificate to the City, designer, installer and Developer/Project Owner certifying compliance with the minimum distribution requirements. Also, form "Substantial Completion of Water Audit" must be completed and sent to Public Utilities. Compliance with this provision is required before the City will release the bond for this project.

- ~~42.14.~~ The irrigation system shall be designed to prevent overspray and water run-off onto adjacent-property, non-irrigated areas, walks, roadways or structures.

- ~~43.15.~~ An automatic irrigation system using pop-up sprinkler heads shall be required for all new landscapes. Low flow sprinkler heads shall be used wherever possible.

- ~~44.16.~~ No irrigation of walkways or drive.

- ~~45.17.~~ Water audit is required prior to bond being released. Suggest the audit be done within 60 days of installing irrigation and landscape.

7.04 PUBLIC UTILITIES BONDS

A. GENERAL

1. Public water, storm water, and street light improvements shall be bonded at 100% estimated cost as determined by Public Utilities.
2. Private water and storm water improvements shall be bonded at 50% estimated cost as determined by Public Utilities.

B. The following table summarizes bonding details/requirements for bonds required by Public Utilities:

PUBLIC UTILITIES BOND DETAILS/REQUIREMENTS

Utility	Items Bonded	% Bond Release	Requirements for Bond Release
Water	Water system (e.g. waterlines, valves, vaults, services, meters, fire hydrants, etc.).	80%	<ul style="list-style-type: none"> • Water system is complete and operating including: <ul style="list-style-type: none"> ○ All lines have satisfactorily passed bacteriological and pressure tests. ○ All valves, fire hydrants, and other appurtenances are fully functional. ○ All meter boxes, valve boxes, fire hydrants, other access vaults are set to final grade, and are accessible to city personnel.
		90%	<ul style="list-style-type: none"> • Water system is complete. • Inspected and signed off by Public Utilities Inspector. • All punch list items have been addressed.
		100%	<ul style="list-style-type: none"> • 1-year warranty period is complete. • All punch list items have been addressed.
Storm Water	Storm water system (e.g. storm drains, boxes, manholes, storm water flow control elements, LID BMPs, storm water treatment facilities, etc.).	90%	<ul style="list-style-type: none"> • Storm water system is complete and operating. • Inspected and signed off by Public Utilities Inspector. • “Letter of Conformance” has been received. • All punch list items have been addressed.
		100%	<ul style="list-style-type: none"> • 1-year warranty period is complete. • All punch list items have been addressed.
Storm Water - SWPPP	Construction/long-term BMPs and individual lot storm water flow control features.	50%	<ul style="list-style-type: none"> • Storm water system is complete and operating. • Inspected and signed off by Public Utilities Inspector. • “Letter of Conformance” received. • Disturbed areas have been seeded. • All punch list items have been addressed.
		100%	<ul style="list-style-type: none"> • 1-year warranty period complete. • NOT has been submitted and approved • All punch list items have been addressed.
Streetlights	Streetlights	90%	<ul style="list-style-type: none"> • Streetlights are complete and operating. • All punch list items have been addressed.
		100%	<ul style="list-style-type: none"> • 1-year warranty period complete. • All punch list items have been addressed.

7.05 WATER

A. GENERAL

1. The City shall be given the first right of refusal to purchase any water rights accompanying the property in the development.
2. All water mains and service laterals shall be installed, pressure tested and bacteriological samples taken in accordance with the Sandy City Standard Specification and Details for Municipal Construction.

3. Any existing water facilities (lines, meters, hydrants, etc.) owned by Sandy City which are found to not meet current City standards and specifications or that are adversely affected by the development during construction, requiring them to be upgraded, moved or otherwise altered to facilitate maintenance (as determined by the City), shall be upgraded, moved, or altered by the Developer at no cost to the City. Water meters/connections that are older than five (5) years, need to be brought up to current Sandy City standards and specifications.
4. Fire flows and fire hydrant placement will be determined by the Fire Marshall during site plan review.
5. Water meter placement location will be determined by Sandy City Public Utilities Department during site plan review and water meter size shall be determined by owner's representative.
6. The Developer is required to pay a water line reimbursement fee based on the frontage of the property for pipe larger than 8-inches that was installed by the City.
7. The Developer is required to grant to the City a minimum of 15-foot wide water line easement (7.5-feet each side of pipe) for all water main lines, around fire hydrants, and around water meters installed on private property, that will be maintained by the City. Easement shall be on a signed standard easement form (template is available from Sandy City Public Utilities) or called out on the plat. Easements shall be completed and submitted to the City after all waterlines have been installed and before the 90% bond release. Structures, buildings, and other utilities shall not be installed within the waterline easement.
8. A separation of 2-feet shall be provided between water services on a ductile iron waterline and a separation of 3-feet shall be provided between water services on a PVC waterline.
9. Future waterline stubs such as water main, fire line and water meter box, and water service lateral shall not be allowed unless a final design has been accepted by Sandy City Public Utilities, on a case-by-case basis.

B. DESIGN

1. Water line pipe material:
 - a) If the project is located west of the Utah Transit Authority's TRAX line, PVC C-900 (DR-14) shall be used for pipe sizes 6-inch thru 12-inch in diameter (see Section 02669 – Water Supply Piping).
 - b) All other pipe shall be Ductile Iron Class 52 or better (see Section 02669 – Water Supply Piping), unless directed otherwise by Sandy City Public Utilities.
 - c) High Density Polyethylene pipe (see Section 02669 – Water Supply Piping) may be used in certain locations/situations only as directed by Sandy City Public Utilities.
2. Water line shall be installed 4-feet off lip of gutter on the north and/or east side of roadway.
3. Water lines shall not be installed within or through parking stalls or under concrete pavement, unless water line is to be maintained by private property owner.
4. Water meters that are 1 ½-inch or larger need to be located in a meter vault (See standard details WTR-10 thru WTR-12).

5. A separate landscape meter is required for commercial projects and projects with common landscaped areas. Call out a landscape meter both in the Utility Plan and in the Irrigation Plan. This meter can be a separate connection to the water main or it can come off the service line after the water meter.
6. All water meters shall be placed in a landscaped area and not in an existing or future driveway.
7. The horizontal distance between water lines and sanitary sewer lines shall be at least 10 feet. Where a water line and a sewer line must cross, the water line shall be at least 18 inches above the sewer line. A variance to this rule may be allowed on a case-by-case basis with additional requirements as approved by Sandy City Public Utilities and/or Utah Division of Drinking Water. Water lines and sewer lines shall not be installed in the same trench.

7.06 STORM WATER

A. GENERAL

1. The City shall be given the first right of refusal to purchase any irrigation shares accompanying the property in the development.
2. Public storm drains should be placed in public rights-of-way to service upstream properties. If storm drains must be placed outside the public rights-of-way, recorded easements are required:
 - a) The Developer shall grant to the City, a 20' wide storm drain or irrigation easement for all storm drains, irrigation lines, and around structures installed on private property, that will be maintained by the City.
 - b) Easements shall be on a signed standard easement form (template is available from Sandy City Public Utilities).
 - c) Easements shall be completed and submitted to the City after all storm drains have been installed and before the 90% bond release.
 - d) Easements shall be exclusive and granted to Sandy City.
 - e) Storm drains and irrigation lines are generally required to be placed in the center of the easement; however, on a case by case basis deviation from this standard can be addressed.
 - f) At all times, a horizontal minimum of 10 feet is required between the storm drain or irrigation line and the edge of the easement.
 - g) The easement shall be accessible from public rights-of way and shall be free of obstructions (including trees).
 - h) Fencing, permanent structures, buildings and other utilities are not be allowed within the easement area.
 - i) The easement area shall allow unrestricted 24 hour/day, 365 days per year access for all purposes related to the ownership, operation, maintenance, alteration, repair, inspection and replacement of storm drain or irrigation line.
 - j) In situations where encroachment into the easement with improvements cannot be avoided, a utility easement encroachment permit and shared utility agreement is required from the property owner.

3. Any existing storm drain and irrigation facilities (pipes, manholes, detention ponds, etc.) owned by Sandy City which are found to not meet current City standards and specifications or that are adversely affected by the development during construction, requiring them to be upgraded, moved or otherwise altered to facilitate maintenance (as determined by the City), shall be upgraded, moved, or altered by the Developer at no cost to the City.
4. For projects that adjoin the East Jordan Canal or Jordan and Salt Lake Canal rights-of-way, the Developer shall obtain a letter of approval from Salt Lake City Public Utilities, a copy of which should be submitted to Sandy City Public Utilities. The Developer shall first send a copy of the site plans, along with the enclosed memorandum, to Salt Lake City Public Utilities. It is recommended that this process be started as soon as possible so as not to delay the construction of the project.
5. For projects that the storm drain system connects to a County Storm Drain System, the Developer should submit a letter, giving approval to connect to the storm drain facilities, from Salt Lake County. It is recommended that this process be started as soon as possible so as not to delay the construction of the project.
6. For projects that the storm drain system connects to UDOT Storm Drain System, the Developer should submit a letter, giving approval to connect to the storm drain facilities from UDOT. It is recommended that this process be started as soon as possible so as not to delay the construction of the project.
7. A letter of approval from the irrigation company is required if storm drain and/or storm drain outfall is located on irrigation company property.
8. A stamped "Letter of Conformance" from the engineer shall be submitted to Public Utilities for final construction approval stating that storm water flow control elements and storm water treatment facilities (e.g. detention, retention, LID Best Management Practices, oil-water separators, mechanical treatment devices, etc.) were constructed according to the approved plans.

B. DESIGN

1. Design of storm water systems shall meet the requirements found in Part 7.0 B - Storm Water Design Criteria.

C. IRRIGATION

1. The Developer is required to provide a continuance of appropriate irrigation facilities for irrigation water users who historically have relied upon facilities on or crossing through the project site, including any needs that may become apparent during or after construction of the project. The design and construction of any irrigation facilities should be approved by any down-stream users, the irrigation company, and by Sandy City Public Utilities.
2. If there is no irrigation easements of record for an existing irrigation facility, an easement must be provided. Contact the irrigation facility owner to determine the required width.
3. It is required that all existing irrigation canal, ditch or pipe that is maintained by Sandy City be replaced with RCP. Irrigation pipes shall be sized to handle the existing flow requirements. Sandy City Public Utilities shall be contacted for information regarding these requirements.
4. There may be existing irrigation facilities which potentially could be abandoned. It is the responsibility of the Developer to complete any research necessary to make

that determination.

5. Irrigation facility design drawings shall be submitted to Sandy City and the ditch owners/users for approval. A letter must be obtained from the irrigation facility owner(s) and user(s) (approving the plans) and submitted to Sandy City Public Utilities.

D. STORM WATER POLLUTION PREVENTION PLAN

1. A Storm Water Pollution Prevention Plan (SWPPP) shall be prepared and submitted with plans for approval by Public Utilities Department. This plan shall meet the requirements of Jordan Valley Municipalities Permit UTS000001, Utah Construction General Permit (CGP) UTRC00000, and/or Common Plan Permit UTRH00000 where required. A copy of the SWPPP shall be submitted electronically.
2. A SWPPP is required to be prepared and submitted for review and approval by the Public Utilities Department for the following cases:
 - a) Land disturbing activity that generally disturbs one or more acres of land;
 - b) Land disturbing activity of less than one acre of land if such activity is part of a larger common plan of development that affects one or more acres of land;
 - c) Land disturbing of less than one acre of land, and, if in the discretion of the Public Utilities Director, such activity poses a unique threat to water quality, air quality, or public health safety;
 - d) The creation and use of borrow pits;
 - e) Development of a single-family home;
 - f) Processing of earthen materials such as topsoil and gravel screening;
 - g) Construction of parking lots;
 - h) Demolitions.
3. If a SWPPP and/or NOI are required for a project, they must be submitted and approved by the Public Utilities Department prior to obtaining any of the following Sandy City permits or approvals:
 - a) Grading permit.
 - b) Subdivision plan approval (residential).
 - c) Site plan approval (commercial).
 - d) Building permit.
 - e) Road cut permit.
 - f) Floodplain Development Permit.

4. For all projects that warrant compliance with the CGP or Common Plan Permit regulation, a Notice of Intent (NOI) for permit coverage must be obtained from Utah State Division of Water Quality under the respective permit. These projects are required to use the most current State templates, in order to satisfy state regulation. The templates are also necessary to create an environment of manageability and equality among all permit applicants.
5. For projects that warrant compliance with the CGP and Common Plan Permit, the SWPPP shall be managed via an internet-based management system.
 - a) The online SWPPP management system shall meet audit requirements of the State of Utah.
 - b) The online SWPPP management system shall be reviewed and approved by the Public Utilities Department prior to approval of the SWPPP and issuance of the permits or approvals listed in the section above.
 - c) Reports and data shall be made available upon request.
 - d) City Staff shall have viewing access rights.
6. There are four categories of SWPPPs based on size and type of development and construction (see below):
 - a) UPDES CGP SWPPP.
 - i. All commercial and industrial projects regardless of size.
 - ii. Demolition of commercial or industrial structures.
 - iii. Projects disturbing an area equal to or greater than 1 acre.
 - iv. Temporary use of borrow pits (including processing and screening of topsoil and gravel).
 - v. New parking lot less than 1 acre.
 - b) UPDES Common Plan SWPPP.
 - i. Residential development projects that disturb less than 1 acre including the following:
 - a. Individual lot.
 - b. Individual lot that is part of a larger common plan of development.
 - c) Small Excavation Project Disturbing Less Than 1 Acre SWPPP.
 - i. This SWPPP may be used at the discretion of the City. Contractor may be directed to use the CGP or Common Plan SWPPP for this category depending on the size and complexity of the project.

- d) Miscellaneous Small Project SWPPP.
 - i. Miscellaneous small project include but are not limited to the following:
 - a. Swimming pools.
 - b. New or replacement driveway.
 - c. Building addition.
 - d. Remodel.
 - e. New garage.
 - f. Overlay or remove and replace parking lot (does not include regrading asphalt projects).
 - g. Residential demolition.
 - h. Sidewalk.
 - i. Curb and gutter.
 - j. Drive approach.
 - k. Work in the park strip.
 - l. Other work in the public right-of-way that does not meet the criteria of the other three SWPPP categories.

E. CONSTRUCTION BEST MANAGEMENT PRACTICES

1. The City adopts as its Best Management Practice (BMP) manuals for construction, the following publications:
 - a) Salt Lake County Public Works Department “Guidance Document for Storm Water Management”.
 - b) Salt Lake Valley Health Department Storm Water Regulations.
 - c) Jordan River Commission “Best Practices for Riverfront Communities”.
 - d) Utah DEQ’s Top Ten BMPs for Construction Sites.
 - e) EPA’s Construction Site Storm Water Runoff Control website.
2. These manuals include lists of acceptable BMPs and specific design performance criteria and operation and maintenance requirements for each storm water practice. The manuals may be updated and expanded from time to time, at the discretion of the governing body of the City, based on improvements in engineering, science, monitory and local maintenance experience.

F. CONSTRUCTION

1. Construction work shall be conducted in accordance with UPDES, CGP, and Common Plan requirements.
2. For projects that warrant compliance with the CGP or Common Plan Permit, inspections shall be completed per the requirements of the CGP or Common Plan Permit. All inspections shall be documented and made available via the online SWPPP management system.
3. Regular review of the online SWPPP management system and inspections may be completed by Sandy City Public Utilities to confirm that construction work is being performed in accordance with CGP or Common Plan Permit requirements. Review and inspection reports completed by Sandy City Public Utilities will be provided to the Contractor which are to be posted to the online SWPPP management system. All identified violations are to be addressed and documented on the online SWPPP management system.
4. SWPPP requirements specific to Sandy City are found in Section 02010 – Storm Water Pollution Prevention Plan Requirements.

G. POST-CONSTRUCTION STORM WATER MAINTENANCE AGREEMENT

1. The purpose of the Post-Construction Storm Water Maintenance Plan and Agreement (PCMA) is to control storm water runoff and reduce pollutants in storm water runoff after construction is complete and the developed site is in operation. This is achieved by accomplishing the following:
 - a) Controlling erosion.
 - b) Controlling discharge of sediment into storm drain facilities or off-site.
 - c) Preventing illicit discharges into on-site soils, storm drainage facilities or off-site.
 - d) Prevention of debris and garbage from entering the storm drain system.
2. A PCMA is required for all privately-owned or maintained facilities that warrant compliance with the CGP regulation.
3. A Post-Construction Storm Water Maintenance Plan must be prepared and submitted with the plans for approval of the PCMA. The plan shall be contained on a plan sheet(s) of its own, rather than being a part of another plan sheet, and is to contain at least the following:
 - a) The site plan, proposed contours, permanent storm water features, and landscaping.
 - b) BMPs to accomplish the purpose of the plan. Examples of appropriate BMPs may include those addressing operation and maintenance of storm drainage quality control facilities, operation and maintenance of storm water discharge control facilities, maintenance of landscaping, good housekeeping practices, etc.

- c) Showing the following for each BMP specified:
 - i. Location and extent of specified BMPs, as appropriate.
 - ii. Detailed schedule of execution for each specified BMP, in terms of starting time, duration, frequency, etc., as appropriate.
 - iii. Any information in addition to or different from that shown on the BMP fact sheets as necessary to employ the BMPs on the site.
- d) For final approval, the Project Owner must submit the original signed and notarized PCMA to Public Utilities. The most current Sandy City Agreement template shall be used.
- e) Once the project has received final approval, Sandy City will record the PCMA at the Salt Lake County Recorder's Office. If there are changes to the storm drain system during construction, the PCMA will need to be modified and recorded.

H. NOTICE OF TERMINATION

- 1. Once the site is stabilized, the site operator must submit a Notice of Termination (NOT) to the Utah State Division of Water Quality and to Sandy City Public Utilities, for projects that warrant compliance with the UCGP and Common Plan Permit regulation. Once the NOT is received by Sandy City Public Utilities, a final inspection will be performed.

7.07 STREET LIGHTS

A. GENERAL

- 1. As per Sandy City Ordinance 01-8, the Developer may be required to install a residential or arterial streetlight along their frontage per Sandy City Standards and Specifications. Locations of the streetlight will be determined during the Preliminary Review.
- 2. Existing streetlights that are found to not meet current City standards and specifications are required to be upgraded per current City standards and specifications.
- 3. The Developer is required to grant to the City a minimum of 15-foot wide electrical easement (7.5-feet each side of pipe) for all conduit and junction box that was installed on private property, that will be maintained by the City. Easement shall be on a signed standard easement form (template is available from Sandy City Public Utilities) or called out on the plat. Easements shall be completed and submitted to the City after all have been installed and before the 90% bond release. Structures, buildings, and other utilities shall not be installed within the streetlight easement.

7.08 UTILITIES

A. GENERAL

1. Residential:

- a) To comply with Sandy City Ordinance 15A-21-19A, All utilities which will serve the parcel being subdivided shall be buried beneath the surface of the ground and shall be located within the easements provided for such use or within the streets at a location to be determined by the City.

2. Commercial:

- a) To comply with Sandy City Ordinance 15A-23-12, all utility lines shall be placed underground in designated easements. No pipe, conduit, cable, line for water, gas, sewage, drainage, steam, electricity, or any other energy or service shall be installed on a permanent basis above ground. However, back flow devices have to be installed above ground. Therefore, no pole or other support structure shall be erected, altered, or replaced upon any lot (outside of any building) above the surface of the ground except for hoses, movable pipes used for irrigation or other purpose during construction.
- b) Each Contractor and Developer/Project Owner shall be responsible to know the whereabouts of all underground utilities. Protection of such utilities shall also be their responsibility. Prior to construction, contact must be made with "Blue Stakes" to identify underground utility lines.
- c) Where overhead poles exist, service lines to new developments must be placed underground from the nearest overhead service pole.
- d) All utility lines associated with the pre-existing utility pole(s) shall be placed underground across the frontage of the development.
- e) All utility boxes, e.g., transformers, switch gear, telephone, cable tv, back flow preventers, etc., shall be shown on the site plan and utility plan and shall be placed a minimum of 5 feet from any sidewalk or parking lot curbing. Said utility boxes shall not be located within any required traffic sight triangle(s), as determined by the City Transportation Engineer and shall be screened from view with appropriate landscaping or architectural elements compatible in material and color with the primary structure. Each box shall be shown in its exact location and shall be noted with its exact height, width, and length. (Ord 09-01, Amended 3-5-2009)
- f) The Developer must contact Rocky Mountain Power for installation service, charges, permits, and related items that they will require for developments that are within Sandy City's borders.

7.09 WATER EFFICIENT LANDSCAPE

A. GENERAL

- 1. A Landscape Plan Documentation Package shall be submitted to and approved by the Sandy City Public Utilities Department as part of the final review process. The

Landscape Plan Documentation Package shall consist of the following items:

- a) Planting Plan. A detailed Planting Plan shall be drawn at a scale that clearly identifies the following:
 - i. Location of all plant materials, a legend with botanical and common names, and size of plant materials.
 - ii. Property lines and street names.
 - iii. Existing and proposed buildings, walls, fences, light poles, utilities, paved areas and other site improvements.
 - iv. Existing trees and plant materials to be removed or retained.
 - v. Designation of Landscape Zones.
- b) Irrigation Plan. Irrigation plans shall be prepared and stamped by a licensed landscape architect or a licensed landscape designer. A detailed Irrigation Plan shall be drawn at the same scale as the planting plan and shall contain the following information:
 - i. Layout of the irrigation system and a legend summarizing the type and size of all components of the system, including manufacturer name and model numbers.
 - ii. Static water pressure in pounds per square inch (psi) at the point of connection to the public water supply.
 - iii. Flow rate in gallons per minute and design operating pressure in psi for each valve and precipitation rate in inches per hour for each valve with sprinklers.
 - iv. Location and Size of Water Meter, which shall be used exclusively for landscape purposes.
 - v. Location of the point of connection, sprinkler heads, backflow prevention device, main and lateral irrigation lines, quick couplers, irrigation controller and moisture sensor overriding device.
 - vi. Size and flow rate of each irrigation zone, valve and sprinkler head; Static water pressure at point of connection; and Symbols, brand name and model number for each sprinkler head and irrigation device.
- c) Landscape Water Allowance. The annual Landscape Water Allowance shall be calculated using the following equation:

$$\text{Landscape Water Allowance} = \text{ETO} \times 1.0 \times 0.62 \times A$$

Where Landscape Water Allowance is in gallons per growing season

ETO = Reference Evapotranspiration in inches per growing season
1.0 = ETO adjustment factor, 100% of turf grass ETO (growing season adjustment factor)

0.62 = conversion factor
A = total Irrigated Landscape Area in square feet

- d) Irrigation Schedule. A monthly Irrigation Schedule shall be prepared that covers the initial 90-day plant establishment period and the typical long-term use period. This schedule shall consist of a table with the following information for each valve:
- i. Plant type (for example, turf, trees, low water use plants).
 - ii. Irrigation type (for example, sprinklers, drip, bubblers).
 - iii. Flow rate in gallons per minute.
 - iv. Precipitation rate in inches per hour (sprinklers only).
 - v. Run times in minutes per day.
 - vi. Number of water days per week.
 - vii. Cycle time to avoid runoff.

B. LANDSCAPE DESIGN

1. Design landscape according to the following criteria - refer to Ordinance ~~15-4121-~~25-4 for additional information:
 - a) Plants are well-suited to microclimate and soil conditions at site, are relatively free from pests and diseases, and are generally easy to maintain.
 - b) Water-Conserving plants are used on slopes exceeding ~~30-~~25 percent.
 - c) Minimum ~~four~~three-inches of mulch on all ~~irrigated~~ non-turf areas. If rock mulch, minimum is three-inches.

C. IRRIGATION DESIGN

1. Design irrigation according to the following criteria - refer to Ordinance ~~15-4121-~~25-4 for additional information:
 - a) Landscape Water Meter and backflow prevention assembly that are in compliance with state code shall be installed separate from the water meter installed for indoor use. The size of the meter shall be determined based on the irrigation demand. This meter must be installed after the main meter and shall remain within the Sandy City Easement. The Developer shall supply the landscape meter and materials. Show on the utility plan and landscape plan.
 - b) Pressure regulator provided where water pressure exceeds 80 psi operating pressure for the sprinkler heads or where significant variation in water pressure will occur.
 - c) Automatic controller provided with multiple program and repeat cycle capabilities, automatic rain shut-off device, and a flexible calendar

program.

- d) On slopes over 30 percent, irrigation system shall consist of Drip Emitters, Bubblers or Sprinklers with a maximum Precipitation Rate of 0.85 inches per hour and adjusted sprinkler cycle times to eliminate runoff.
- e) Each valve irrigates area with similar site, slope, and soil conditions and plants with similar water needs. Turf and non-turf areas irrigated on separate valves.
- f) Drip Emitters or a Bubbler shall be provided for each tree where practicable. Bubblers shall not exceed 1.5 gallons per minute per device. Bubblers for trees shall be on a separate valve unless specifically exempted by Sandy City Public Utilities due to the limited number of trees on the project. Filters and end flush valves shall be provided as necessary.
- g) Sprinklers have matched Precipitation Rate within each valve.
- h) Check valves specified where low-head drainage will occur due to elevation differences. Pressure compensating valves and sprinklers shall be required where a significant variation in water pressure will occur within the irrigation system due to the limited number of trees.
- i) Irrigation zones with overhead spray or stream sprinklers shall be designed to operate between 6:00 pm and 10:00 am to reduce water loss from wind and evaporation. This would exclude drip or bubbler zones.
- j) Following Construction and prior to release of the secondary bond guarantee posted for the project, a Water Use Efficiency Review will be conducted by a Landscape Irrigation Auditor. The auditor shall be independent of the Contractor, design firm, and Developer/Project Owner. The water performance audit will verify that the irrigation system complies with the minimum standards required by Sandy City ordinance. The minimum efficiency required for the irrigation system is 60% for distribution efficiency for all fixed spray system and 70% distribution efficiency for all rotor systems. The auditor shall furnish a certificate to the City, designer, installer and Developer/Project Owner certifying compliance with the minimum distribution requirements. Compliance with this provision is required before the City will release the bond for this project.

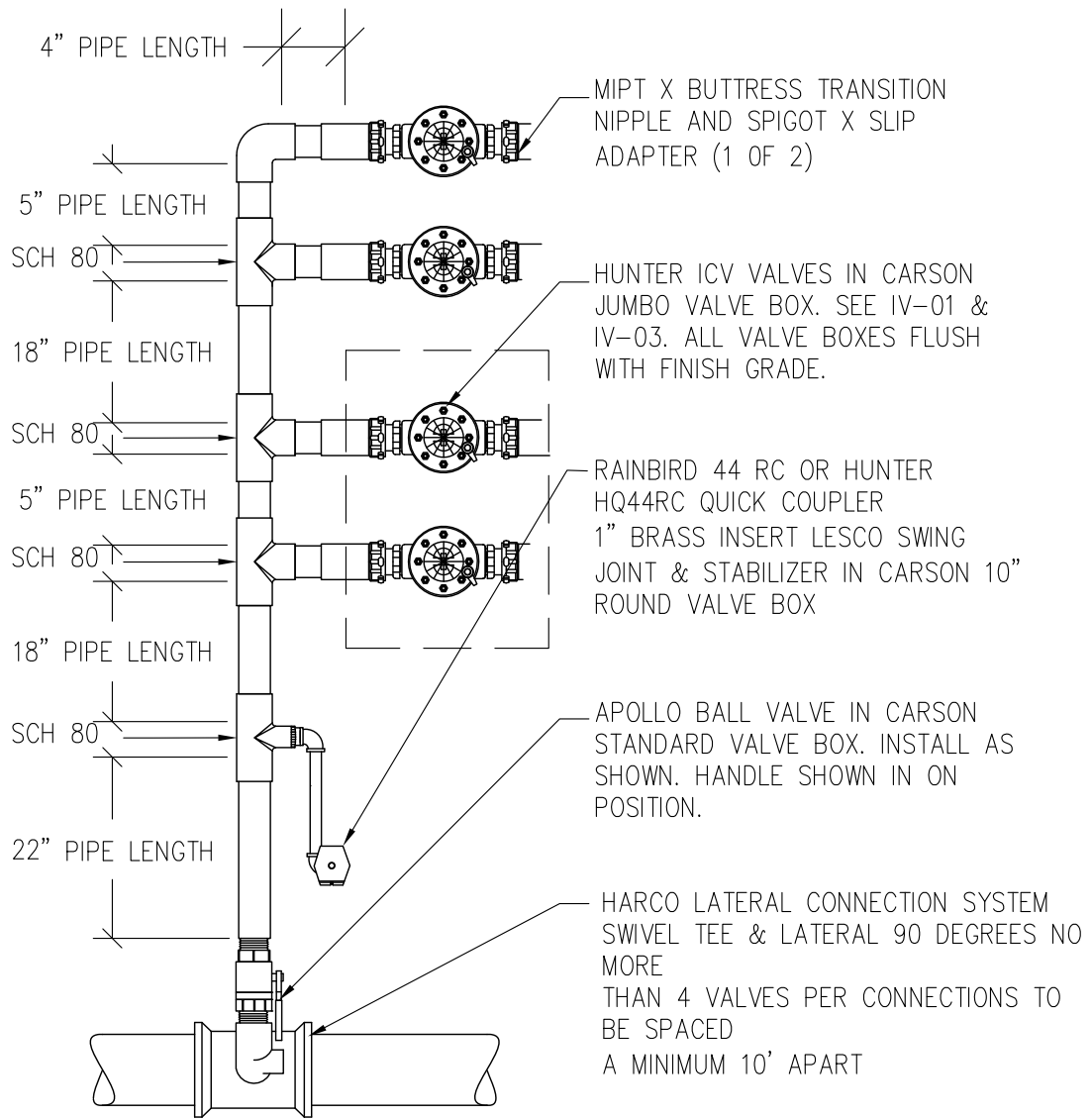

NOTE:
ALL MAINLINE FITTINGS TO BE SCH. 80 AND OR HARCO

1	C Kirk	DWG REVISION	5/1/17
1	D MEDINA	DWG REVISION	10/26/22
NO.	AUTHORIZED BY	REVISIONS	DATE



STANDARD DETAIL
PARKS & RECREATION
IV-02

VALVE MANIFOLD

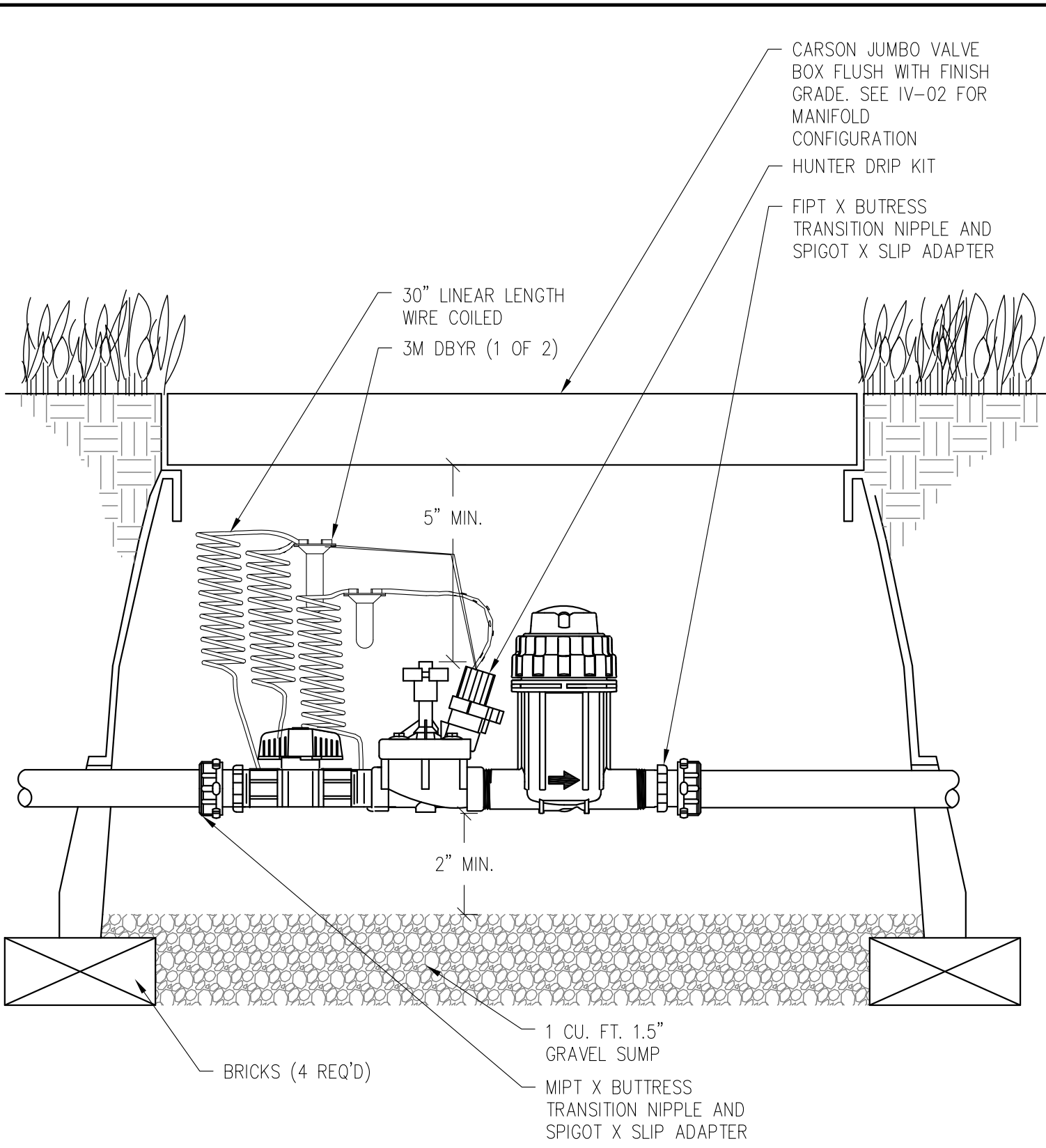

NOTE:
ALL MAINLINE FITTINGS TO BE SCH. 80 AND OR HARCO

1	C Kirk	DWG REVISION	5/1/17
1	D MEDINA	DWG REVISION	10/26/22
NO.	AUTHORIZED BY	REVISIONS	DATE



STANDARD DETAIL
PARKS & RECREATION
IV-03
DRIP VALVE ASSEMBLY

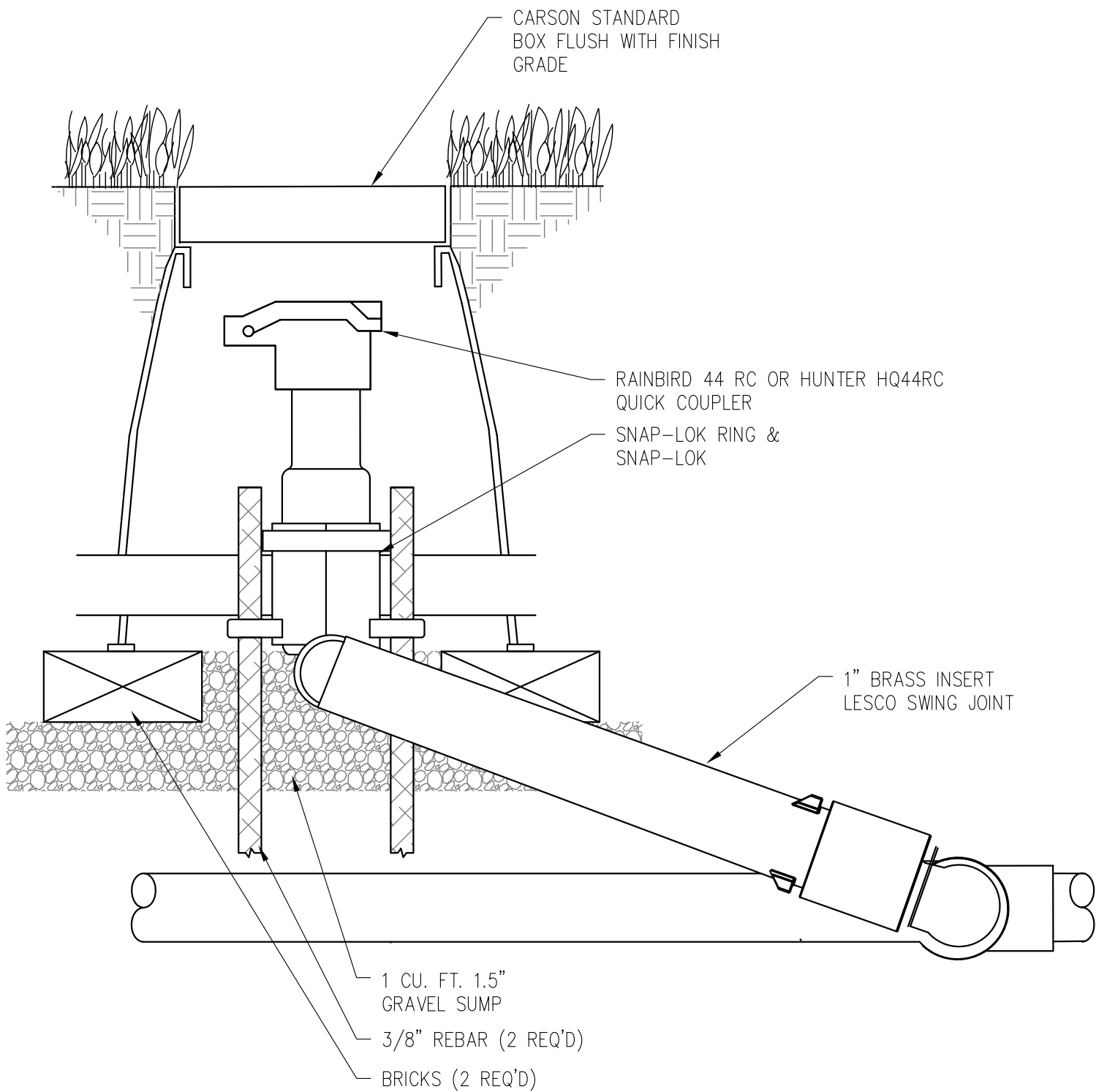

1	C Kirk	DWG REVISION	5/1/17
1	D MEDINA	DWG REVISION	10/26/22
NO.	AUTHORIZED BY	REVISIONS	DATE

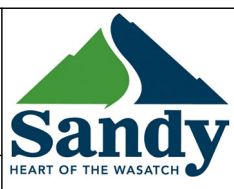

STANDARD DETAIL
PARKS & RECREATION
IV-04
QUICK COUPLER VALVE

SECTION 02503

BITUMINOUS PAVING COURSE

Follow APWA Section 32 12 16.13 Plant-Mix Bituminous Paving

APWA Link

PART 1 - GENERAL

1.01 - WORK INCLUDED

- ~~A. - Furnish all labor, materials, and equipment as required to mix, place, and compact a plant mix bituminous surface course.~~
- ~~B. - Prepare base course and compact prior to placing surface course.~~
- ~~C. - Prepare existing surfaces to be overlaid and install tack coat. Install geotextile paving fabric prior to placing surface course if required.~~
- ~~D. - Obtain permit and provide traffic control as required.~~
- ~~E. - Comply with requirements of Section 01041.~~

1.02 - RELATED WORK AND REFERENCES

- ~~A. - Division 1 - General Requirements~~
- ~~B. - Section 02260 - Engineering Geotextile Fabric~~
- ~~C. - Section 02505 - Bituminous Tack Coat~~
- ~~D. - Section 02513 - Bituminous Concrete Paving Materials~~
- ~~E. - Section 05000 - Material Testing~~
- ~~F. - ASTM D 2170 - Kinematic Viscosity of Asphalts (Bitumens)~~
- ~~G. - ASTM D 2950 - Density of Bituminous Concrete in Place by Nuclear Method.~~

1.03 - SUBMITTALS

- ~~A. - As required by Section 02513.~~

PART 2 - PRODUCTS

2.01 - BITUMINOUS MATERIAL

- ~~A. - Use the bituminous material as required on the plans in conformance with the requirements of Section 02513.~~
- ~~B. - If the source of asphalt changes during the course of the work, submit a new mix design.~~
- ~~C. - Do not intermix the asphalt from two different sources or gradations.~~

2.02 - MINERAL AGGREGATE

- ~~A. - Unless otherwise specifically designated on the plans or in the special provisions, use imported natural gravel, crushed gravel, crushed rock, or crushed slag conforming to the requirements of Section 02513 at the specified gradation.~~

~~2.03 — TACK COAT~~

- ~~A. — Furnish and apply a tack coat in conformance with the requirements of Section 02505.~~

~~2.04 — TEMPERATURE CONTROL~~

- ~~A. — Complete compaction operations before the temperature of the bituminous mixture drops below 220° F.~~

~~PART 3 — EXECUTION~~

~~3.01 — MIXING~~

- ~~A. — Use a mixing system that will supply bituminous paving materials in conformance with Section 02513. Supply materials that are of the proper temperature, gradation, and mix consistency as defined in the Marshall Mix design.~~
- ~~B. — Adjust the production of the mixing plant and material delivery so that a continuous uninterrupted forward paving speed operation is obtained.~~

~~3.02 — PREPARATION~~

- ~~A. — Locate, reference, and protect all utility covers, monuments, curb and gutters, and other structures in place prior to paving.~~
- ~~B. — Provide 48 hours written notice to residents and businesses as outlined in Section 01041, 3.04.~~
- ~~C. — For overlay process, clean road surface of debris, dust and gravel utilizing vacuum type equipment. Remove all water from surface and allow to dry.~~
- ~~D. — Apply a water soluble herbicide for removal of all vegetation within the paving limits; Monsanto Roundup or approved equal.~~
- ~~1. — Apply herbicide a minimum of seven days prior to paving operations. Coordinate directly with Engineer.~~
- ~~2. — Apply herbicide solution with a shield applicator that directs the solution onto the desired vegetation while shielding adjacent property and improvements.~~
- ~~3. — Replace any adjacent property or improvements damaged through this operation.~~
- ~~E. — Patch holes and level any uneven areas as identified 24 hours prior to placing surface course.~~
- ~~F. — Allow all adjacent concrete to cure for either seven days or until 75% of specified strength (f'c) is obtained prior to beginning paving operations.~~

~~3.03 — PAVING FABRIC INSTALLATION (WHEN REQUIRED)~~

- ~~A. — Geotextile paving fabric shall comply with specifications as outlined in Section 02260.~~
- ~~B. — Apply the type and amount of asphaltic sealant specified by the manufacturer or as approved by the Engineer. Apply sealant 6" beyond the area covered by the fabric to insure adequate coverage.~~
- ~~C. — Place fabric on substrate with no wrinkles. Cut fabric and overlap on curved roadways to prevent wrinkles as per manufacturer recommendation. Place fabric while asphaltic sealant is still tacky. Place correct surface of fabric against sealant. Meet all placement standards recommended by manufacturer.~~
- ~~D. — Broom fabric to increase contact with asphaltic sealant.~~

- ~~E. Overlap fabric at seams six (6) inches minimum. Overlap ends in "shingle" fashion in direction of overlay to ensure the end does not pick up.~~
- ~~F. Place overlay on fabric immediately after lay down and brooming.~~
- ~~G. Apply extra sealant at each fabric overlap area to seal joints.~~
- ~~H. Blot fabric with sand where sealant may have penetrated before laying down the overlay to ensure that the overlay machine or delivery equipment do not pick up the fabric.~~
- ~~I. Use care in turning, stopping, and starting equipment to ensure that the fabric is not twisted or wrinkled.~~
- ~~J. Repair tears or wrinkles by cutting and patching as specified in 3.03.E above.~~
- ~~K. Place fabric 18 inches from lip of curb with a minimum depth of 1-1/2 inches of bituminous mix.~~

~~3.04 SPREADING AND COMPACTION~~

- ~~A. Maintain the temperature of the bituminous mixture in the lay down operation at not more than 310° F. and not less than the value shown in the following chart.~~

MINIMUM LAY DOWN TEMPERATURE CHART (Fahrenheit)					
————— Compacted Paving Mat Thickness					
Ambient Air Temperature	3/4"	1"	1-1/2"	2"	3"
45-49					280
50-59				280	270
60-69			285	275	265
70-79		285	280	270	265
80-89	280	275	270	265	260
90+	275	270	265	260	255

- ~~B. Do not place asphalt when the ambient air temperature is below that allowed in the table for the given mat thickness and when frozen materials are present in the base or sub-base.~~
- ~~C. Spread the bituminous mixture with self-propelled mechanical spreading and finishing equipment capable of spreading the mixture to the proper grade, thickness, and typical section as specified in the plans or as designated by the Engineer. Pull lengths shall be a maximum of 1320 feet (1/4 mile) when using pickup machine. Pull lengths shall be a maximum of 800 feet when using any other equipment, to minimize the occurrence of cold longitudinal joints.~~
- ~~D. Use spreader box or other methods of spreading the material approved by the Engineer for small projects under 200 square yards, for irregular areas, for miscellaneous construction such as detours, sidewalks, and for initial leveling courses.~~
- ~~E. Unless otherwise designated or directed, place bituminous surface course more than three inches in total compacted thickness in two or more courses with no course exceeding three inches in compacted thickness. Top lift will be a two-inch minimum thickness.~~

- ~~F. Offset longitudinal joints 12 inches in succeeding courses and at least six feet transversely to avoid a vertical joint through more than one course. In the top course of minor collectors or larger facilities, restrict joint to one foot either side of the centerline of travel lane lines.~~
- ~~G. Provide sufficient equipment to compact the mixture to density meeting section 05000. Coordinate with an independent testing agency and the Engineer to develop a rolling pattern for compaction. Utilize the approved pattern as long as the compactive efforts are within specification.

 - ~~1. Provide sufficient rolling equipment to keep pace with the laydown operation.~~
 - ~~2. Use a release agent other than diesel fuel, unless specifically approved by Engineer.~~~~
- ~~H. Roll the surface longitudinally, beginning at the outside edge or lower side and proceeding toward the higher side. Overlap each pass of one roller over the preceding pass by at least one-half the width of the roller. For finish rolling, pneumatic rollers are required.~~
- ~~I. Place the bituminous mix as a continuous operation. Do not allow rollers to pass over the unprotected end of freshly placed mix. If so authorized and the end will be subjected to traffic, bevel the end at approximately 5:1 (horizontal to vertical). Make transverse joints by cutting back on the previous run to expose the full depth of the layer or course. Apply a light coat of bituminous tack coat, in conformance with Section 02505, on the contact surfaces just before fresh bituminous mix is placed against previously compacted mix. At bridge ends or at ends of other rigid-type structures, compact transversely as well as longitudinally.~~
- ~~J. Prevent traffic, including construction traffic, from crossing the vertical edge. Apply tack coat to the vertical edge prior to making another pass with the paver if the bituminous mix has cooled below 150° F.~~
- ~~K. Adjust production of mixing plant and paving material delivery to obtain a continuous uninterrupted forward paving operation. Contractor will provide sufficient labor and equipment to ensure a continuous paving operation.~~

~~3.05 FINISH~~

- ~~A. Place the bituminous course to the line, grade, elevations, thickness cross section and finish as shown on the plans or as directed by the Engineer.~~
- ~~B. Minimum pavement section:~~

Road Class	Right of Way width	Bituminous Paving Course	U.T.B.
Residential	60' or less	3" PG 58-28 (1/2" aggregate)	8"
Minor Collector	62' to 68'	4" PG 58-28 (1/2" aggregate)	8"
Major Collector	82'	4" PG 58-28 (1/2" aggregate)	12"
Arterial	86' or greater	5" PG 64-34 (3/4" aggregate)	12"

~~Note: For all roadways west of I-15 or in areas where the subgrade contains clay, install a minimum 4" pavement section (3/4" aggregate) unless specified by the Engineer. Geotextile fabric is required in roadways west of I-15, or in clay, under the base section or as directed by the Engineer.~~

- ~~C. Construction joints will be measured with a ten-foot straight edge. When tested longitudinally across the joint, the surface cannot vary more than 0.013 feet in ten feet. Bring the joint into specification tolerance immediately after the paving machine has moved away.~~
- ~~D. The variation of the surface from the testing edge of the string line between any two contacts with the surface will at no point exceed 0.025 feet for longitudinal measurements. The variation of the surface from the testing edge of the straight edge between any two contacts with the surface will at no point exceed 0.01 feet for transverse measurements.~~

~~Correct all humps or depressions exceeding the specified tolerances at no expense to the City with a method approved by the Engineer.~~

~~3.06 WEATHER AND SEASONAL LIMITATIONS~~

- ~~A. Place bituminous surface course only between April 15 and October 15 and when the air temperature in the shade and the roadbed temperature are as noted in 3.04, B. Do not place bituminous surface course during rain, when the roadbed is wet, or during other adverse weather conditions.~~
- ~~B. Bituminous surface course can be placed after October 15 only upon written authorization from the Engineer. An extended warranty period, additional pavement depth, and/or other considerations may be required.~~

~~C. For cold weather patching, emergencies, or other situations where conditions do not comply with 3.04, B, all bituminous surface course placed will be considered temporary and will be removed and replaced in accordance with this section and Section 02115.~~

~~3.07 ACCEPTANCE~~

~~A. Refer to Section 05000, 5.02.~~

~~3.08 TEMPORARY SURFACING~~

~~A. Temporary bituminous resurfacing will be at least two inches thick and consist of HMA. HMA mix design must be approved by the Engineer. "Cold Patch" is not allowed.~~

~~B. At major intersections and other critical locations a greater thickness may be required by Engineer.~~

~~C. Place temporary resurfacing as soon as the condition of the backfill is suitable and leave in place until ready for permanent resurfacing.~~

~~D. Maintain temporary surfacing until removal and replacement with permanent surface course.~~

~~PART 4 MEASUREMENT AND PAYMENT~~

~~4.01 TEMPORARY RESURFACING~~

~~A. Material which is placed by the contractor for his convenience or to maintain traffic will be placed at no cost to the City. The unit price for temporary material shall consist of full compensation for furnishing, placing, maintaining, removing, and disposing of such temporary surfacing materials.~~

~~4.02 PRICE ADJUSTMENT~~

~~A. Price adjustments for deficient material will be as outlined in Section 05000, 5.03.~~

END OF SECTION

SECTION 32 12 16.13
PLANT-MIX BITUMINOUS PAVING

PART 1 GENERAL

1.1 **SECTION INCLUDES**

- A. Place a bituminous concrete pavement base course, leveling course, surface course, overlay course, or an inlay course.

1.2 **REFERENCES**

A. **AASHTO Standards:**

- R9 Acceptance Sampling Plans for Highway Construction.
P68 Bulk Specific Gravity and Density of Compacted Asphalt Mixtures Using Automatic Vacuum Sealing Method.
T324 Hamburg Wheel-Track Testing of Compacted Hot-Mix Asphalt (HMA).

B. **ASTM Standards:**

- D979 Sampling Bituminous Paving Mixtures.
D1188 Bulk Specific Gravity and Density of Compacted Bituminous Mixtures Using Coated Samples.
D2041 Theoretical Maximum Specific Gravity of Bituminous Paving Mixtures.
D2726 Bulk Specific Gravity and Density of Non-Absorptive Compacted Bituminous Mixtures.
D2950 Density of Bituminous Concrete in Place by Nuclear Method.
D3549 Thickness or Height of Compacted Bituminous Paving Mixture Specimens.
D3665 Random Sampling of Construction Materials.
D5361 Sampling Compacted Bituminous Mixtures for Laboratory Testing.
D6927 Marshall Stability and flow of Bituminous Mixtures.

1.3 **DEFINITIONS**

- A. **Must Grind:** Defined in Section 32 01 31.
B. **Road Class:** Defined in Section 32 01 31.
C. Quality Control/Owner Verification Testing: Defined in Section 32 12 05

1.4 **SUBMITTALS**

- A. Bituminous Concrete Mix Design, Section 32 12 05
B. **Before Delivery:** Submit 48 hours before delivery:
1. Materials Quality Data, this section Article 1.5
2. [Traffic control plan, Section 01 55 26.](#)
3. Manufacturer's certificate of compliance for paving geotextiles. (Refer to [Section 31 05 19](#)).
4. Certification of profilograph and profilograph operator.
5. Cold weather paving plan.
C. **At Delivery:** For each batch delivered to site provide a paper or electronic (e-ticket) delivery ticket with the following:
1. Date and project description.
2. Producer and plant.
3. Name of contractor.
4. Serial number of ticket.
5. Mix identification number or code.
6. Truck number and time dispatched.

- 7. Weight of mix delivered.
 - D. **After Placement:**
 - 1. **Quality Control Test Report:** If required by Section 32 12 05S, submit density and thickness Quality Control data to the Engineer within 3 working days after completion of each day of paving or prior to the start of the next paving day, whichever is sooner.
 - 2. **After Placement:** Before final payment submit summary report describing profile deviation and profile roughness. [Section 32 01 31](#).
- 1.5 **MATERIALS QUALITY**
- A. Do not change aggregate source or binder grade until ENGINEER accepts new source and new mix design.
 - B. Perform Quality Control efforts identified in article 3.8.
 - C. Reject product and work that does not meet requirements of this Section.
 - D. Remove product found defective after installation and install acceptable product at no additional cost to **OWNER**.
 - E. Foreman of paving crew has completed at least three (3) projects of similar size and nature.
 - F. For all equipment and hand tools used to mix, haul, and place the bituminous concrete, use a release agent that does not dissolve asphalt and is acceptable to ENGINEER.
- 1.6 **WEATHER**
- A. Temperature:
 - 1. April 15 to October 15: Place pavement when air temperature in the shade and the roadway surface temperature are above 50 deg F. The ENGINEER determines may provide written approval if it is acceptable to place outside of this temperature limit.
 - 2. Before April 15 and After October 15: Provide a Cold Weather Paving Plan. ENGINEER must accept the plan before proceeding. Include the following details.
 - a. Haul details.
 - b. Placement details.
 - c. Compaction aids used in production.
 - d. Additional equipment and procedures for achieving compaction.
 - e. Coordination procedure for acceptance testing.
 - B. Moisture: Do not place on frozen base, during adverse climatic conditions such as precipitation, or when roadway surface is wet or icy.
- 1.7 **NOTICE**
- A. Follow [Laws and Regulations](#) concerning when and to whom notices are to be given. Send written notice at least three (3) days before start of paving.
 - B. Indicate paving time and when new surface can be used.
 - C. Warn of potential vehicle tow away and other construction issues affecting neighborhood.
 - D. Should work not occur on specified day, send a new notice.
- 1.8 **OWNER VERIFICATION TESTING and ACCEPTANCE**
- A. **General:**
 - 1. Acceptance is by **Lot**.
 - 2. If non-complying material has been installed and no price for the material is specified, apply pay adjustment against cost of work requiring complying material as part of its installation, [Section 01 29 00](#).
 - 3. Dispute resolution, [Section 01 35 10](#).
 - 4. Opening a paved surface to traffic does not constitute acceptance.
 - 5. Observation of CONTRACTOR's field quality control testing does not constitute acceptance. Such testing; however, may be used by ENGINEER for acceptance if requirements of Section 01 35 10 are met.
 - B. **Mix Material:** Accepted as specified for [bituminous concrete, Section 32 12 05](#), or [rubberized asphalt concrete, Section 32 12 08](#).
 - C. **Mix Temperature at Site:**

1. Reject mixes in the transport material exceeding the limits identified in the mix design.
 - a. Use calibrated temperature probes for rejection of mix. Use temperature guns for quick approximate temperature readings only.
 2. Dispose of cold mix in paver hopper as thin spread underlay.
- D. **Grade, Cross Slope:** Perform minimum one grade and one cross-slope check per sub-lot.
- E. **Compaction:** Options for acceptance are 1) core density, 2) non-destructive test density, or 3) control strip density with visual observation. Use core density unless specified elsewhere. A Lot is acceptable if density test averages are within pay factor 1.00 limits and no test is below Lowest Test limit. For remediated sublots, include remediated sub-lot tests in Lot evaluation.
1. Un-Accepted Lots: At the Engineer’s discretion, a lot with an average deviation that does not meet 1.00 pay factor and does not have an individual test deviation greater than pay factor 0.80 allowed limits may be accepted with a pay factor in accordance with Table 1.
 - a. Lots with a mat pay factor lower than 0.80 or with a sub-lot with a test deviation greater than the pay factor 0.80 limits, and with Engineer and Contractor concurrence, are subject to an Engineering Analysis.

Table 1 – Compaction Pay Factors				
Pay Factor	Mat Density, in Percent Relative to ASTM D2041 (a)		Joint Density, in Percent Relative to ASTM D2041 (a) (d)	
	Average	Lowest Test	Average	Lowest Test
0.80	More than 98.0	–	More than 98.0	–
1.00	93.0 to 98.0	90.0 or greater	91.0 to 98.0	89.0 or greater
0.90	93.0 to 98.0	Less than 90.0	91.0 to 98.0	Less than 89.0
0.80	Less than 93.0	90.0 or greater	Less than 91.0	89.0 or greater
Eng. Analysis	Less than 93.0	Less than 90.0	Less than 91.0	Less than 89.0

Notes:

- (a) For overlay design thicknesses of less than 2.0”, mat density targets are reduced by 1% and no joint density cores are taken.
- (b) Difference based on actual subplot mat density and subplot core density values.
- (c) Report and calculate all density values to 0.1%.
- (d) A paving Joint is defined as a longitudinal seam between two adjacent passes of asphalt placed during the project, and where the initial pass cools below 180 deg F prior to placement of the adjacent pass. Do not take Joint cores where the “Joint” is comprised of existing asphalt or concrete. Use 6” diameter cores for joint density determination.

2. **Core Density:** This method compares the average density of cores extracted from a pavement surface to maximum theoretical density. Contractor to take cores in the presence of and immediately deliver to the Engineer or Engineer’s representative.
 - a. Mat Lot Size: One (1) day production.
 - b. Mat Sampling Protocol: Use ASTM D3665 to randomly select in each sub-lot at least one (1) surface test location. Samples are full depth or overlay depth in overlay construction.
 - 1) Projects less than 500 Tons: Use 10 sublots and non-destructive tests. Coring may be used for dispute resolution.
 - 2) Projects between 500 and 1000 Tons: Use 4 equal sublots.
 - 3) Projects between 1000 and 1500 Tons: Use 6 equal sublots
 - 4) Projects greater than 1500 Tons: Use 8 equal sublots.
 - b. Joint Sampling Protocol: Use ASTM D3665 to randomly select a total of three (3) longitudinal joint test locations for each joint. Samples are full depth or overlay depth in overlay construction.
 - 1) Use 6” diameter cores, centered within 1 inch of center of joint.
 - 2) Do not core projects smaller than 250 Tons.
 - c. Testing Protocol: ASTM D2726 for core density and ASTM D2041 (Rice) for maximum theoretical density.
3. **Non-Destructive Density Testing by Electronic Gauge:**

- a. Lot Size: One (1) day production, with sublots as defined in Article 1.8.E 2 Core Density.
- b. Mat Sampling Protocol: Use ASTM D3665 to randomly select in each sub-lot at least two (2) surface test locations.
- c. Testing Protocol: ASTM D2950 (nuclear gauge) or AASHTO TP68 (non-nuclear gauge) and ASTM D2041 (Rice) for maximum theoretical density. A non-destructive test is the average of two (2) test samples at each test location with a minimum 90 degree offset between test samples using mix correlated gauges. Use minimum 60 second count with Nuclear Gauge.

4. **Compaction Dispute Resolution:**

- a. Submit an Engineering Analysis for approval within one week of receipt of test results or at least 24 hours before performing any work that may prevent the evaluation, correction, or removal of the lot in question.
 - b. Include information, engineering analysis, statistical analysis, and test results related to the dispute.
 - 1. Reasons for disputing the acceptance or verification test results.
 - 2. The Contractor’s project quality control test results, including any split sample test results.
 - a) Test results must be from a UDOT qualified laboratory using UDOT qualified technicians, or results must be verified and certified (stamped) by a Utah Registered Professional Engineer.
 - b) Include all supporting test data and calculations for reported values.
 - 3. Successful laboratory correlation information when required by material specification.
 - 4. Statistical analysis or identification of potential outliers.
 - 5. Procedures or issues leading to disputed acceptance test results.
5. Provide recommended corrective measures or adjusted pay factor based on engineering evaluation based on durability and serviceability relative to the specified product requirements, including expected performance compared to design life.

F. **Thickness:** A Lot is acceptable if average of test deficiencies, applied to the **total design thickness**, exceeds design thickness or is within pay factor 1.00 limits; and no subplot or individual test below 0.90 pay factor.

- 1. **Un-Accepted Lots:** At the Engineer’s discretion, a lot with an average deviation that does not meet 1.00 pay factor and does not have a sub-lot test deviation greater than pay factor 0.90 allowed limits may be accepted with a pay factor in accordance with Table 2.
 - a. Lots with a pay factor lower than 0.90 or with a sub-lot with a test deviation greater than the pay factor 0.90 limits, and with Engineer and Contractor concurrence, are subject to an Engineering Analysis.

Table 2 – Thickness Pay Factor	
Pay Factors	Deficiency Limits, in Inches
1.00	0.00 to 0.25
0.90	0.25 to 0.375
Remediate	>0.375

- 2. **Lot Size:** One (1) day production with 1,000 square yard sub-lots or part thereof.
- 3. **Sampling Protocol:** Use ASTM D3665 to randomly select at least one surface test location and one longitudinal joint test location in each sub-lot. Samples are full depth. Overlay construction measured only on overlay portion of core sample. Use one of the following methods for thickness determination:
 - a. Measurement of Density Cores

- b. Probe of uncooled mix – perform between intermediate and final rolling operations.
 - c. Ground Penetrating Radar (not applicable to overlay applications).
 - 1) Perform GPR evaluation by scanning and recording depth for full-width of the pavement at one random location for each subplot. Engineer will mark locations for scans. Measure HMA thickness every 6 inches on the recorded scan. Calculate the average thickness, and the percentage of the thickness below each of the tolerance levels described in Article 1.8 F 5.
4. **Testing Protocol:** ASTM D3549:
- a. Minimum Specified Thickness (Cores or Probes): A Lot specified to have minimum thickness will be accepted if all sub-lot measurements meet or exceed minimum.
 - 1) Cores not meeting full payment will be provided to the Contractor for verification of measurements.
 - 2) If thickness is deficient, additional material may be placed over the deficient thickness if rotomilling is utilized for edge tie-in; placement matches this section’s thickness tolerance; surface continues to drain; and roughness tolerance is met.
 - b. Actual Specified Thickness (Cores or Probes): A Lot specified to have actual thickness is acceptable if any sub-lot measurement does not exceed deficiency limits for thickness pay factor 1.00.
 - c. A lot is accepted for thickness based on GPR evaluation when:
 - 1) The average thickness of all scans is not more than ¼ inch less than the total thickness specified.
 - 2) No individual scan shows a deficient thickness of more than ⅜ inch for more than 5% of any scan.
5. **Thickness Dispute Resolution:**
- a. CONTRACTOR:
 - 1) Hire an [Independent Testing Agency, Section 01 45 00](#), or perform in the presence of Engineer (or their representative)
 - 2) Coring Option:
 - i. Take two (2) additional cores midway between deficient acceptance test locations, and midway between a deficient test location and the next adjacent acceptable test location.
 - ii. Patch core holes.
 - 3) Ground Penetrating Radar (GPR) Option:
 - i. Use GPR to determine extents of deficient area.
 - 4) Conduct testing at no additional cost to OWNER.
 - b. ENGINEER:
 - 1) Graph deficient areas by plotting new cores and original cores, or GRP results, to define deficient areas assuming the following.
 - a) The graph represents the thickness of the pavement.
 - b) Thicknesses vary linearly along the pavement length from core depth to core depth.
 - c) The pavement is a constant depth in the transverse direction.
 - 2) Accept Lot at full pay if new information shows minimum of 95% of sub-lot area is in compliance, or
 - 3) Accept Lot at pay reduction using new test information, or
 - 4) Reject Lot.
 - c. REJECT LOTS:
 - 1) Remediate reject thickness lots by adding additional thickness of bituminous concrete, adhering to all requirements of Sections 32 12 05

and 32 1216.13.

- 2) Utilize rotomilling as necessary to achieve proper cross-slope and elevations in relation to existing curb and gutter.

6. **Excess Thickness:** For projects paid by the ton, payment will be made for excess tonnage for thickness up to 1/2" over design thickness. Additional tonnage for thickness above 1/2" will be paid at a 50% pay factor.

G. **Profile Roughness and Profile Deviation:** [Section 32 01 31](#).

1.9 WARRANTY

- A. Joints at [Street Fixtures](#) and Portland Cement Concrete Flat Work: If wider than 1/2 inch before end of the [correction period](#) seal joints with asphalt rubber or rubberized asphalt; [Section 32 01 17](#).

PART 2 PRODUCTS

2.1 MATERIALS

- A. [Bituminous concrete, Section 32 12 05](#).
- B. [Tack coat, Section 32 12 13.13](#).
- C. [Prime coat, Section 32 12 13.19](#).
- D. [Paving geotextile, Section 31 05 19](#).
- E. [Paving geogrid, Section 31 05 21](#).

PART 3 EXECUTION

3.1 CONSTRUCTION EQUIPMENT

- A. Paver Machine: Use track equipment when operating on fabrics, geogrids or [pavement](#) mats hotter than 180 deg F
- B. Compactors: Steel wheel static or vibratory. Use pneumatic tire roller for intermediate rolling only.

3.2 PREPARATION

- A. General:
 1. Locate and preserve utilities [Section 01 31 13](#). Contact utility companies and other agencies, for dangerous concentration of combustible, flammable, or explosive matter.
 2. Lower [Street Fixtures](#) if paving machine is not capable of passing over the fixtures.
 3. Remove vegetation from cracks, edges and joints. Sweep surface clean. Blow cracks clean. Remove leaves.
 4. Fill cracks and fix [Potholes, Section 32 01 17](#).
 5. Stabilize Portland cement concrete [subgrade](#) slabs.
- B. Traffic Control:
 1. [Implement notification and traffic control plan requirements, Section 01 55 26](#). Do not proceed without certified flaggers.
 2. Apply temporary lane marking tape or paint after layout has been verified with [ENGINEER](#).
- C. Aggregate Base Course:
 1. Do not pave on aggregate base course without written confirmation from the general contractor that the aggregate base course has been inspected and meets the requirements of the project approving authority.
 2. Do not pave on uncompacted or uneven base course. Placement over uneven base course will not be acceptable justification for thickness deficiencies.
 3. If indicated, follow [Section 31 31 19 requirements for herbicide treatment](#) or [Section 32](#)

12 13.19 for prime coat applications.

3.3 **PROTECTION**

- A. Trees, Plants, Ground Cover:
 - 1. Protect trees, plants and other ground cover from damage.
 - 2. Prune trees to allow equipment passage underneath, [Section 32 01 93](#). Repair tree damage at no additional cost to **OWNER**.
- B. Protect all structures, including curb, gutter, sidewalks, guard rails and guide posts from physical damage. Remove spatter, over-coat, or mar.
- C. Do not discharge bituminous materials into borrow pits or gutters.
- D. Protect hot pavement from traffic until cool enough not to become marred.
- E. Remove saw-cut dust immediately. Protect neighborhood, storm drains and down-stream fish habitat.

3.4 **TEMPORARY SURFACING**

- A. Place, roll, maintain, remove and dispose of temporary **Pavement** surfaces.
- B. In sidewalk areas construct temporary **pavements** at least 1 inch thick and in all other areas at least two (2) inches thick. At major intersections and other critical locations a greater thickness may be required.

3.5 **LINE AND GRADE CONTROL**

- A. Provide necessary survey stakes for horizontal and vertical control.
- B. Furnish, place, and maintain supports, wire devices, and materials as required to provide continuous line and grade reference controls for placing pavement, matching existing pavement surfaces, etc.

3.6 **FABRIC PLACEMENT**

- A. [Section 31 05 19](#).

3.7 **PAVEMENT PLACEMENT**

- A. General:
 - 1. Barricade off or eliminate fall off edges.
 - 2. Provide continuous forward paver movement so temperature 10 feet behind paver is as follows:
 - a. Warm Mix Placement: 200 deg F minimum.
 - b. Hot Mix Placement:

Table 3 – Minimum Pavement Temperature in Degrees F.						
Air Temperature Deg F	Compacted Mat Thickness					
	3/4"	1"	1-1/2"	2"	3"	4"+
45 – 50	–	–	–	–	280	265
50 - 59	–	–	–	280	270	255
60 - 69	–	–	285	275	265	250
70 - 79	285	285	280	270	265	250
80 - 89	280	275	270	265	260	250
90 +	275	270	265	260	250	250

- B. Overlays or Subsequent Lifts:
 - 1. Allow new base **pavement** or new inlay **pavement** to cure (harden) before placing overlays.
 - 2. Apply tack coat per [Section 32 12 13.13](#) if inlay or sub-base **Pavement** surface is dirty or older than 24 hours.
- C. Irregular Areas: Handwork is acceptable if specified grade, slope, compaction and smoothness are achieved.
- D. Compaction:
 - 1. Test mix placement for density until a compaction pattern is acceptable to **CONTRACTOR**. Continue random quality control testing throughout placement.

2. Do not over compact or under compact.
 3. Complete compaction before mix cools to uncompactable condition. Cease compaction efforts if aggregate begins to fracture.
- E. Joints:
1. Construct joints to industry standards for texture, density and smoothness. Construct upslope matt flush or above downslope matt. Meet transverse smoothness requirements.
 2. Clean contact surfaces and apply tack coat. Ensure continuous bond between old and new **pavements**, or between successive day's work.
 3. Offset longitudinal joints a minimum of 12 inches in succeeding courses and at least six (6) feet transversely to avoid a vertical joint through more than one course. In the top course restrict longitudinal joint to 1 foot either side of lane lines.
 4. Prevent traffic, including construction traffic, from crossing vertical edges. Apply tack coat to vertical edges before making another pass with paver if mix has cooled to 90 deg F.

3.8 QUALITY CONTROL

- A. For projects less than 500 tons, perform Quality Control as identified below if identified as required by section 32 12 05s or project documents. For projects greater than or equal to 500 tons, perform Quality Control as identified below.
- B. Compaction
1. Use trained and experienced Density Technicians
 - a. Use technicians trained in the aspects of gauge operation and offsets, rolling patterns, mat temperature maintenance.
 - b. Use technicians that have controlled a minimum of 3 previous projects under the supervision of a UDOT TTQP certified (current certifications that cover sampling, density and field asphalt properties) technician.
 2. Develop Rolling Pattern for achieving density using gauges (nuclear or non-nuclear) correlated to mix being supplied.
 3. Perform systematic testing to verify full lot placement (length, width and joints) is in conformance with density requirements.
 4. Do not substitute owner Quality Assurance activities for Quality Control. Owner QA activities may be used to correlate Quality Control activities and devices.
- C. Thickness
1. Perform systematic depth determinations throughout each subplot. Determinations may be made on compacted mix, or on uncompact mix with appropriate adjustment for compaction.
 2. Perform a minimum of two depth determinations for each edge of paving pass and for center of paving pass for each subplot.
- D. Submit Quality Control Documentation to Engineer within 72 hours of placement of Lot, or prior to any subsequent overlay, whichever is sooner.

3.9 TOLERANCES

- A. Lift Thickness: If not indicated, meet the following tolerances.

Table 4 – Lift Thickness Tolerance (a)		
Mix	Minimum	Maximum
Bituminous Concrete	2.5 times <i>nominal</i> aggregate size	4.0 inches (b)
NOTES (a) Thickness is measured after compaction. (b) Maximum lift thickness may be exceeded if contractor can demonstrate ability to achieve consistent compaction from top to bottom of lift without breaking down aggregate. Determine compaction consistency by cutting a minimum of 3 random cores in half vertically and testing top and bottom half of cores. If density range between top half and bottom half of		

each core is equal to or less than 1%, compaction consistency is verified. If range exceeds 1%, placement must adhere to Maximum lift thickness requirement.

- B. Smoothness:
 - 1. Parallel to Centerline: [Section 32 01 31](#).
 - 2. Cross Slope: 1/4 inch in 10 feet except at cross section grade breaks.

3.10 **SURFACE REPAIR**

- A. Repair ride disturbing or unsafe butt joints. Repair expense is at no additional cost to OWNER.
- B. If pavement smoothness is deficient, follow Section 32 01 31 repair requirements.
- C. Corrective Action for Profile Deviations (“Must Grinds”): Grinding is acceptable. See [Section 32 01 26](#). Apply a fog seal over grind areas. See [Section 32 01 13.50](#). If depressions cannot be corrected by grinding, remove and replace.
- D. Corrective Action for Profile Roughness Index: Grinding is acceptable. Re-profile corrected segments to verify ride index meets tolerance. Apply a fog seal over grind areas. See [Section 32 01 13.50](#).
- E. When thickness is deficient, place additional material over deficient areas. DO NOT skin patch. Mill for inlay if necessary.
- F. Defective Joints, Seams, Edges: Repair.
- G. Unacceptable Paving: Remove and replace.

3.11 **OPENING TO TRAFFIC**

- A. Temperature of pavement surface is not more than 180 deg F

END OF SECTION

SECTION 02513

BITUMINOUS CONCRETE PAVING MATERIALS

Follow APWA Section 32 12 05 – Bituminous Concrete

APWA Link

PART 1 – GENERAL

1.01 – WORK INCLUDED

- ~~A. — Furnish all labor, materials, additives, and equipment as required for the production of bituminous concrete paving materials by plant mixing and meeting the requirements of this specification.~~
- ~~B. — Furnish all required material certifications and test data as required.~~
- ~~B. — Obtain permit and provide traffic control as required.~~

1.02 – RELATED WORK AND REFERENCES

- ~~A. — Division 1 – General Requirements~~
- ~~B. — Section 02503 – Bituminous Paving Course~~
- ~~C. — Section 02505 – Bituminous Tack Coat~~
- ~~C. — UDOT Section 402 – Asphalt Concrete Pavement~~
- ~~E. — Comply with applicable AASHTO, ASTM, and UDOT test procedures~~

1.03 – SUBMITTALS

- ~~A. — Prior to using pavement mixes, submit a Marshall mix design using ASTM D 1559 procedures. With the mix design also submit the following information:
 - ~~1. — Mix suppliers name and address.~~
 - ~~2. — Mix designers name.~~
 - ~~3. — Bill of Lading from asphalt vendor showing asphalt grade and hydrated lime used, if required.~~
 - ~~4. — Calculation sheets justifying the following:
 - ~~a. — Bitumen content in mix.~~
 - ~~b. — Marshall stability – 1200 pounds minimum.~~
 - ~~c. — Flow (0.01 inch) – 10 to 18.~~
 - ~~d. — Voids content 2 – 4%.~~~~~~
- ~~B. — If contractor opts to use a pre-approved supplier, submit the name and address of the supplier along with the mix design prior to using the mix on site. The contractor will conform to the following requirements:
 - ~~1. — The contractor will within 15 working days prior to the date of paving submit in writing which local supplier they will use.~~
 - ~~2. — Only one supplier can be used unless written approval from the Engineer is obtained. Under no conditions can an asphaltic mixture from different sources be used during the same day.~~~~

- ~~3. It is the contractor's responsibility to notify the City in writing 15 working days prior to paving if the supplier wishes to change their approved mix design.~~
- ~~4. Submit the Bill of Lading from the vendor for the bituminous material showing asphalt grade and hydrated lime used.~~

~~1.04 SAMPLING AND TESTING~~

- ~~A. Gradation and Bitumen Content: As per Section 05000, 5.01.A.~~
- ~~B. Sieve Analysis: As per Section 05000, 5.01.B.~~

~~PART 2 PRODUCTS~~

~~2.01 GENERAL REQUIREMENTS~~

- ~~A. Use bituminous material as specified in 2.02.A below.~~

~~2.02 ASPHALTIC CEMENT~~

- ~~A. Asphaltic Cement: Furnish asphalt cement meeting the requirements of ASTM D 3381, with the following modification. Delete the loss on heating requirement on residue from "Thin-Film Oven Test." Delete the ductility at 25°C. (77° F.) and replaced with ductility at 4°C. (39.2° F). Use the following values:~~

~~AC-10: greater than 15
AC-20: greater than 5~~

- ~~a. For arterial roadways use Performance Grade (PG) 64-34, SP ¾, 75 Nd meeting APWA specification Section 32-12-05 - Superpave.~~

~~2.03 ASPHALTIC EMULSIONS (SLURRY SEAL)~~

- ~~A. Anionic emulsified asphalt conforming to the requirement of ASTM D 977.~~
- ~~B. Cationic emulsified asphalt conforming to the requirements of ASTM D 2397.~~

~~2.04 AGGREGATE MATERIALS~~

- ~~A. Use mineral aggregate that consists of crushed stone, crushed gravel, or crushed slag conforming to the following requirements:~~
 - ~~1. Comply with APWA Section 32-12-05.~~
- ~~B. RAP (Reclaimed Asphalt Pavement) limited to maximum 15% of mix design.~~

~~2.05 HYDRATED LIME~~

- ~~A. Unless otherwise approved by the Engineer, the addition of hydrated lime will be added meeting the following requirements:~~
 - ~~1. Anti-stripping agent prohibited.~~
 - ~~2. Add hydrated lime to the aggregate to increase the unconfined compressive strength of the bituminous mix. Determine the exact amount of lime to be added. Submit at least three complete Marshall designs and three sets of Immersion-Compression tests based on the mineral aggregate used and the amount of lime added to bring the material in compliance with the specifications. Engineer will approve the amount of lime added as a part of the mix design.~~

~~2.06 AGGREGATE GRADATION~~

- ~~A. Use an aggregate that the combined dry mineral aggregate is uniformly graded and of such size that it meets the gradations specified below when tested in accordance with AASHTO~~

~~T-30. Use the gradation designated on the plans. When a specific gradation is designated do not use any other unless authorized in writing by the Engineer.~~

~~B. Gradation for Bituminous Paving Course:~~



3/4 INCH GRADATION

		Ideal
		Gradation
		Ideal
Sieve Size	(Percent Passing)	Gradation Tolerance
3/4 inch	100	0
3/8 inch	83	±8
No. 4	54	±8
No. 16		28
	+6	
No. 50		17
	+6	
No. 200	5	±2

1/2 INCH GRADATION

		Ideal
		Gradation
		Ideal
Sieve Size	(Percent Passing)	Gradation Tolerance
2 inch		100
		0
No. 4	70	±10
No. 16		35
		±7
No. 50		17
		±6
No. 200	5	±2

b. For arterial roadways, meet APWA Specification Section 32-12-06.

PART 3 EXECUTION

3.01 MIXING AND PLACEMENT

A. Mix, place, and finish the asphalt concrete paving materials in accordance to the requirements of Section 02503.

SECTION 32 12 05
BITUMINOUS CONCRETE

PART 1 GENERAL

1.1 SECTION INCLUDES

- A. Composition of a bituminous concrete mix.
- B. For placement of a bituminous concrete mix, refer to Section 32 12 16.13.

1.2 REFERENCES

A. AASHTO Standards:

- M323 Superpave Volumetric Mix Design, Single User Digital Publication
- R18 Standard Recommended Practice for Establishing and Implementing a Quality Management System for Construction Materials Testing Laboratories
- R30 Mixture Conditioning of Hot-Mix Asphalt (HMA)
- T324 Hamburg Wheel-Track Testing of Compacted Hot-Mix Asphalt (HMA)

B. Asphalt Institute Standards:

- SP-2 SUPERPAVE Mix Design Series No. 2

C. ASTM Standards:

- C29 Unit Weight and Voids in Aggregate.
- C88 Soundness of Aggregates by Use of Sodium Sulfate or Magnesium Sulfate.
- C117 Materials Finer Than 0.075mm (No. 200) Sieve in Mineral Aggregates by Washing.
- C131 Resistance to Degradation of Small-Size Coarse Aggregate by Abrasion and Impact in the Los Angeles Machine.
- C136 Standard Method for Sieve Analysis of Fine and Coarse Aggregate.
- C142 Clay Lumps and Friable Particles in Aggregates.
- D75 Sampling Aggregates.
- D140 Sampling Bituminous Materials.
- D242 Mineral Filler for Bituminous Paving Mixtures.
- D979 Sampling Bituminous Paving Mixtures.
- D995 Mixing Plants for Hot-Mixed, Hot-Laid Bituminous Paving

Mixtures.

- D2041 Theoretical Maximum Specific Gravity of Bituminous Paving Mixtures.
- D2419 Sand Equivalent Value of Soils and Fine Aggregate.
- D3203 Percent Air Voids in Compacted Dense and Open Bituminous Paving Mixtures.
- D3665 Random Sampling of Construction Materials.
- D3666 Minimum Requirements for Agencies Testing and Inspecting Bituminous Paving Materials.
- D4318 Liquid Limit, Plastic Limit, and Plasticity Index of Soils.
- D4552 Classifying Hot-Mix Recycling Agents.
- D4791 Flat or Elongated Particles in Coarse Aggregate.
- T283 Effect of Moisture on Asphalt Concrete Paving Mixtures (Lottman Test).
- D5444 Mechanical Size Analysis of Extracted Aggregate.
- D5821 Determining the Percentage of Fractured Particles in Coarse Aggregate.
- D6307 Determining Asphalt Content of Hot-Mix Asphalt by Ignition Method.
- D6373 Performance Graded Asphalt Binder.

1.3

DEFINITIONS

A. **Mix Designator:** An alphanumeric code that identifies binder grade, aggregate grade, and compaction level for a bituminous concrete mix. For example, in *PG64-34, SP-1/2, 75Nd*:

1. Binder grade (PG64-34): The alpha portion represents Performance Graded Asphalt Binder. The numerical portion represents the grade of the binder.
2. Aggregate gradation (SP-1/2): The alpha portion represents Superpave mix. The numerical portion represents the nominal maximum sieve size. aggregate gradation.
3. Compaction level (75Nd): This is the compaction level using Superpave mix design process.

B. **Bituminous Binder:** A graded bituminous cement composed of any of several viscous or solid mixtures of hydrocarbons and their nitrogen and sulfur derivatives, whose combined properties meet a defined standard.

1. Virgin Asphalt Binder: A refined or manufactured bituminous cement known as performance graded asphalt binder (PG or PGAB).
2. Recycled Asphalt Binder: A bituminous cement contained in

recycled asphalt pavement known as performance graded asphalt binder (PG or PGAB).

C. Binder Grades:

1. Virgin Binder Grade: The grade of asphalt binder received from binder supplier and added to the mix.
2. RAP Binder Grade: The grade of recycled asphalt binder contained in recycled asphalt pavement.
3. Resultant Binder Grade: The resultant grade of binder in the mix based on blending of virgin binder and RAP binder grades.
4. Design Binder Grade: The required grade of binder for the pavement based on environmental conditions, also the virgin asphalt binder specified when using 15% or less RAP.

D. Mean of Deviations: [Defined in Section 32 11 23.](#)

E. Nominal Maximum Size: One sieve size larger than first sieve size retaining more than 10 percent of the [Sample](#). One hundred percent of the aggregate might be able to pass through the nominal maximum size sieve but not more than 10 percent will be retained on the sieve below. The **maximum size** sieve will be one (1) sieve size larger than the nominal maximum size.

F. RAP: Acronym for reclaimed asphalt pavement. A granular product recovered from a bituminous pavement containing aggregate and an Asphalt Binder.

G. Quality Control: Sampling, testing and inspection efforts performed by the Contractor to control the mix production and placement operations. Locations, times, practices and personnel (other than Lab AMRL Accreditation and minimum requirements in Article 3.3) are the contractor's decision.

1. Requirements for Quality Control that may/will be used in acceptance decisions will be defined by the Owner in Section 32 12 05S - Project Specific Surfacing Requirements.

H. Owner Verification Testing: Sampling, testing and inspection efforts, and personnel/laboratory qualifications that are utilized by the Owner to verify compliance of the mix production and placement with specifications. Locations, times, practices and personnel are at the Owner's decision.

I. Road Class: Road Class as identified in Section 32 12 05S – Project Specific Surfacing Requirements, or as defined in section 32 01 31 Pavement Smoothness if not in 32 12 05S.

1.4 **SUBMITTALS**

A. General:

1. Pre-approved Mix Design: Submit name and address of [Supplier](#).

2. Allow ENGINEER 10 days to evaluate mixing equipment and mix design submittals.
3. Once a mix design is accepted, a new mix design submittal is required if the following occurs.
 - a. Asphalt Binder grade is changed.
 - b. Aggregate source is changed. When this occurs, submit a physical properties report on the proposed aggregates.

B. Quality Control:

1. Certified Laboratory: Submit names, certification levels, and years of experience of Quality Control field technicians that are assigned to the Work. Verify laboratory complies with ASTM D3666 or AASHTO R-18, and follows [Section 01 45 00](#) requirements.
2. Mix Production Equipment: Submit verification by an individual acceptable to ENGINEER, that plant equipment complies with requirements of ASTM D995.
3. Testing Report: If identified by contract requirements, submit a report of source quality control testing performed by [CONTRACTOR](#) and Suppliers.
4. Testing Report: If identified by Section 32 12 05S – Project Specific Surfacing Requirements, submit Quality Control data to the Engineer within 3 working days after completion of each day of paving or prior to the start of the next paving day, whichever is sooner.
5. Plant Production Report: If identified by Section 32 12 05S – Project Specific Surfacing Requirements, submit daily plant production records to the Engineer within 1 working day after completion of each day of paving and prior to the start of the next paving day.
 - a. Plant report must include weights of all individual aggregates, bitumens, water and other additives incorporated in mix, including RAP, lime, mineral filler, fiber or other additives.

C. Mix Design: Submit the following.

1. Valid mix design.
 - a. Mix designs dated from the previous paving season (calendar year) are invalid unless accompanied by a letter from the Asphalt Supplier certifying that the mix design is still valid for the current paving season.
 - b. Mix designs dated prior to the previous paving season are invalid.
 - c. Mix designs are invalid if aggregate source or binder grade are

changed.

- d. Invalidated mix designs must be revalidated for volumetric properties (minimum 4 pucks, $\pm 0.2\%$ from targets), or a replaced with a new mix design.
2. Virgin Binder source and grade, and Resultant Binder grade.
3. Optimum compaction temperature at the project site.
4. Theoretical maximum specific gravity.
5. Compaction density at design target air voids.
6. [Target Grading Curve](#) for aggregate.
7. Binder target percentage.
8. Dust to binder ratio.
9. Voids in the mineral aggregate (VMA).
10. Voids filled with Asphalt (Bituminous Binder), also known as VFA.
11. Hamburg Wheel Tracker results, if required
12. Percentages of 1) mineral filler, 2) anti-strip (if required), 3) reclaimed bituminous (asphalt) pavement (RAP), 4) recycle agent in the mix, and 5) virgin aggregate.
13. Aggregate physical properties (this section article 2.2). The information is for suitability of source and not for project control. A new report may be required if aggregate source is changed. Test results shall not be older than two (2) calendar years from the date of submission.1.5

1.5 MATERIALS QUALITY

- A. Do not change aggregate source or binder grade until [ENGINEER](#) accepts new grades and new or revalidated mix design.
- B. HMA Mixing Plant: Capable of meeting ASTM D995 requirements or use UDOT Qualified Plant.

1.6 ACCEPTANCE

A. General:

1. Acceptance is by [Lot](#). One (1) Lot is one (1) days' production. At Engineer's discretion and in concurrence with the contractor, multiple small lots may be combined into one lot. Obtain concurrence prior to placement of lots.
2. If non-complying material has been installed and no price for the material is specified, apply pay adjustment against cost of work requiring material as part of its installation, [Section 01 29 00](#).
3. If test results are not within this section's limits, options include correction of production procedures or production of an alternate

mix design acceptable to ENGINEER.

4. Observation of CONTRACTOR's field quality control testing does not constitute acceptance. Such testing; however, may be used by ENGINEER for acceptance if requirements in [Section 01 35 10](#) are met.

B. Mix Sampling and Testing:

1. Sub-lot size is 500 tons or part thereof.
 2. Sampling Protocol: ASTM D3665 and ASTM D979. Collect at least one (1) random Sample per sub-lot from behind paver and before compaction. For placements with a design thickness of 2 inches or less, samples may be taken at the plant. Any sample collected because of non-uniform appearance shall not be used in determining a pay factor for the Lot.
 - a. Sampling binder, ASTM D140. At owner's request, take 1 qt sample and provide to owner's representative.
 3. Testing Protocol (Performed by Owner's Verification Testing Organization):
 - a. Project Less than 1000 tons – At Owner's discretion, mix samples will be compacted in the laboratory and tested for:
 - 1) Binder content, ASTM D6307.
 - 2) Aggregate gradation, ASTM D5444.
 - 3) Maximum Specific Gravity (Rice), ASTM D2041
 - b. Project greater than 1000 tons - Mix samples will be compacted in the laboratory and tested for:
 - 1) Air voids, ASTM D3203.
 - 2) Voids in the mineral aggregate, AI MS 2.
 - 3) Binder content, ASTM D6307.
 - 4) Aggregate gradation, ASTM D5444.
 - 5) Maximum Specific Gravity (Rice), ASTM D2041
 4. Reporting: The Owner or the Owner's Verification Testing organization will provide the contractor with acceptance results within 3 working days after completion of each day of paving, or prior to the start of the next paving day, whichever is sooner.
- C. Lot Acceptance:** A Lot is acceptable if binder content and aggregate gradation test average deviations are within pay factor 1.00 limits in Table 1 and no sub-lot deviation exceeds 0.85 pay factor limit.
- D. Un-Accepted Lots (Contracts Issued by Someone Other Than The Ultimate Owner of The Pavement):** Provide recommended corrective measures based on Engineering Analysis, described below, based on durability and serviceability relative to the specified product requirements, including expected performance compared to design life.

The ultimate owner of the pavement or a representative of such will review and either approve corrective measures or provide basis for rejection.

E. **Un-Accepted Lots (Contracts Issued by The Ultimate Owner of The Pavement):** At the Engineer’s discretion, a lot with an average deviation that does not meet 1.00 pay factor and does not have a sub-lot test deviation greater than pay factor 0.85 limits may be accepted with a pay factor in accordance with Table 1.

1. Lots with a pay factor lower than 0.85 or with a sub-lot with a test deviation greater than the pay factor 0.85 limits, and with Engineer and Contractor concurrence, are subject to an Engineering Analysis.

Table 1 – Pay Factors					
Criteria	Pay Factor	Range of Mean of Deviations of Tests Results in Percentage Points from Binder and Gradation Targets			
		500 Tons	1,000 Tons	1,500 Tons	≥ 2,000 Tons
Binder Content	1.00	0.0 – 0.46	0.0 – 0.41	0.0 – 0.38	0.0 – 0.35
	0.95	0.47 – 0.58	0.42 – 0.52	0.39 – 0.58	0.36 – 0.52
	0.90	0.59 – 0.64	0.53 – 0.56	0.59 – 0.64	0.53 – 0.56
	0.85	0.65 – 0.69	0.57 – 0.61	0.65 – 0.69	0.57 – 0.61
Nominal Sieve	1.00	0.0 – 6.3	0.0 – 5.6	0.0 – 5.3	0.0 – 5.0
	0.95	6.4 – 7.9	5.7 – 7.0	5.4 – 7.9	5.1 – 7.0
	0.90	8.0 – 8.7	7.1 – 7.7	8.0 – 8.7	7.1 – 7.7
	0.85	8.8 – 9.5	7.8 – 8.4	8.8 – 9.5	7.8 – 8.4
No. 8 Sieve	1.00	0.0 – 4.8	0.0 – 4.3	0.0 – 4.0	0.0 – 3.8
	0.95	4.9 – 6.0	4.4 – 5.3	4.1 – 5.0	3.9 – 4.3
	0.90	6.1 – 6.6	5.4 – 5.8	5.1 – 5.6	4.4 – 4.8
	0.85	6.7 – 7.2	5.9 – 6.4	5.7 – 6.2	4.9 – 5.4
No. 50 Sieve	1.00	0.0 – 3.8	0.0 – 3.3	0.0 – 3.0	0.0 – 2.8
	0.95	3.9 – 5.0	3.4 – 4.3	3.1 – 4.0	2.9 – 3.3
	0.90	5.1 – 5.6	4.4 – 4.8	4.1 – 4.6	3.4 – 3.8
	0.85	5.7 – 6.2	4.9 – 5.4	4.7 – 5.2	3.9 – 4.4
No. 200 Sieve	1.00	0.0 – 2.0	0.0 – 1.8	0.0 – 1.8	0.0 – 1.8
	0.95	2.1 – 2.4	1.9 – 2.2	1.9 – 2.2	1.9 – 2.2
	0.90	2.5 – 2.7	2.3 – 2.4	2.3 – 2.4	2.3 – 2.4
	0.85	2.8 – 3.0	2.5 – 2.6	2.5 – 2.6	2.5 – 2.6
NOTES					
(a) Test binder content using a burn-off oven, ASTM D6307.					
(b) Determine aggregate gradation by extraction, ASTM D5444.					

F. **Engineering Analysis:**

1. Submit an Engineering Analysis, performed and stamped by a Utah Registered Professional Engineer or Mix Supplier QC Manager with commensurate experience in materials and pavements performance, for approval within one week of receipt of test results or at least one working day (M-F) before performing any work that may prevent the evaluation, correction, or removal of the lot in question.
2. The engineering analysis shall include the following:

- a. Reasons for disputing the acceptance or verification test results.
- b. The Contractor's project quality control test results, including any split sample test results.
 - 1) Test results must be from a UDOT qualified laboratory using UDOT qualified technicians, or results must be verified and certified (stamped) by a Utah Registered Professional Engineer.
 - 2) Include all supporting test data and calculations for reported values.
- c. Successful laboratory correlation information when required by material specification.
- d. Statistical analysis or identification of potential outliers.
- e. Procedures or issues leading to disputed acceptance test results.
- f. Impact of results on pavement performance and recommended cost adjustment to impacted materials based on impact to pavement performance.

G. **Installation:** See [Section 32 12 16.13](#) acceptance requirements.

PART 2 PRODUCTS

2.1 BINDER

A. **Performance Graded Asphalt Binder (PGAB):** See ASTM D6373.

1. Use the following minimum virgin mix binder grades unless otherwise specified.

Table 2 – Minimum Virgin Binder Grade		
Road Class	Elevation	
	Above 4000 Feet	Below 4000 Feet
Class I & II	PG 58-28 (\leq 15% RAP) PG 64-34 ($>$ 15% RAP) (a)	PG 64-22 (\leq 15% RAP) PG 58-28 ($>$ 15% RAP)
Class III	PG 64-34 (a) (Up to 30% RAP)	PG 70-28 (\leq 15% RAP) PG 64-34 ($>$ 15% RAP)
a. Blending chart limitations for mixes exceeding 15% RAP must meet -28 for low end PG temperatures.		

2. Adjust virgin binder grade to accommodate RAP contents in excess of 15% as identified in Table 2. Do not use grades lower than xx-34. Use M323 Appendix X1 Blending chart to determine acceptable RAP content up to maximum allowed based on virgin binder grade selected or additives incorporated. Submit RAP binder grading and

blending charts with mix design.

3. Use of Virgin Binder Grades exceeding the minimums, i.e. grades with ranges encompass greater temperature ranges than required for virgin binder, is acceptable.

2.2 AGGREGATE

- A. Crushed stone, crushed gravel, slag, sand, or combination.
- B. Use Table 3 to determine suitability of aggregate source.

Table 3 – Aggregate Physical Properties				
		Standard	Road Class	
			I & II	III
Coarse Aggregate				
Angularity, percent, minimum	One Fractured face	D5821	90	95
	Two Fractured faces		90	90
Wear (hardness or toughness), percent, maximum		C131	35	35
Flats or elongates (3:1 length to width), percent, maximum		D4791	--	20
Fine Aggregate				
Angularity (uncompacted void content), percent, minimum		T304	40	45
Sand equivalent, percent, minimum		D2419	45	60
Plastic limit, maximum		D4318	0	0
Blended Physical Properties				
Dry-rodded Unit Weight, lb/ft ³ , minimum		C29	75	75
Weight Loss (Soundness), percent, maximum		C88	16	16
Friable particles, percent, maximum		C142	2	2
NOTES				
(a) Coarse aggregate is material retained on No. 4 sieve.				
(b) Fine aggregate is material passing No. 4 sieve.				
(c) Angularity is determined by weight.				
(d) Wear of aggregate may have higher values if aggregate source is known to have higher values.				
(e) Sand equivalent is waived for RAP aggregate but applies to the remainder of the aggregate blend.				
(f) Plastic limit, passing No. 40 sieve. Aggregate is non-plastic even when filler material is added to the aggregate.				
(g) Weight loss, using sodium sulfate.				
(h) Friable particles are clay lumps, shale, wood, mica, coal passing the No. 4 sieve, and other deleterious materials.				
(i) Road class as identified in project documents and as defined in Section 32 01 31				

2.3 ADDITIVES

- A. Mineral Filler: ASTM D242.

- B. Recycle Agent: ASTM D4552.
- C. Anti-strip Agent: Heat stable cement slurry, lime slurry, or chemical liquid as required to meet Tensile Strength Ratio (Lottman) or Hamburg test requirements.
- D. **RAP**: Free of detrimental quantities of deleterious materials.
 - 1. Use RAP Content as requirements of Table 2.
 - 2. Determine RAP binder content by chemical extraction.

2.4

MIX DESIGN**A. Preparation:**

- 1. Road Class as defined by Section 32 12 05S – Project Specific Surfacing Requirements.
- 2. Determine submittal requirements from [paragraph 1.4C](#).

B. Aggregate Gradation: See Table 4. The [Target Gradation Curve](#) for the specified aggregate grade must lie within the [Master Grading Band](#) limits. The target grading band limits for the Target Grading Curve are the appropriate grading limits for pay factor 1.00 in Table 1. The target grading band limits are allowed to extend outside of the Master Grading Band limits.

Table 4 - Master Grading Bands - Superpave Mix Design		
Sieve	Gradation Limits of Target Gradation	
	SP-1/2	SP-3/8
3/4 inch	100	–
1/2 inch	90.0 – 100	100
3/8 inch	< 90.0	90.0 – 100
No. 4	–	< 90.0
No. 8	28.0 – 58.0	32.0 – 67.0
No. 200	2.0 – 10.0	2.0 – 10.0
NOTES		
(a) Gradation is expressed in percent passing by weight per ASTM C136. Percentage of fines passing No. 200 sieve determined by washing per ASTM C117.		
(b) The numerical portion of the grade designator (1/2, 3/8) represents the <i>nominal maximum</i> sieve size. Comparable <i>maximum</i> mix designs would be one sieve size larger, i.e. ½” nominal (superpave) maximum is comparable to ¾” maximum (Marshall).		

C. Design Parameters: Determined by AI SP-2 and in accordance with Table 5.

Table 5 - Mix Design Parameters	
Compaction Level (a)	Asphalt Institute SP-2
<i>Road Class I/II</i>	50Nd
<i>Road Class III</i>	75Nd
Design Air Void Target, percent (b)	3.5
Voids in Mineral Aggregate (VMA) relative to nominal sieve size grading and calculated using Gsb(dry), percent, minimum	ASTM D3203
Class II and III: SP-1/2	14.2
Class I: SP-3/8	15.2
RAP specific gravity for calculations	Gsb (dry) by chemical extraction
Dust to Binder Ratio, maximum	1.6
Tensile Strength Ratio (moisture sensitivity), minimum (a,c)	AASHTO T283
<i>Road Class I (e)</i>	80% or HWT
Rutting (Hamburg Rut Test) (a,d)	AASHTO T324
<i>Road Class II</i>	15 mm/10,000 passes
<i>Road Class III</i>	10 mm/20,000 passes
NOTES	
<p>(a) Road Class as identified in project documents and as defined in Section 32 01 31.</p> <p>(b) Design Density Target: ASTM D2041. Percent of maximum theoretical specific gravity.</p> <p>(c) Tensile Strength Ratio (moisture sensitivity): Use one cycle of Freeze-thaw conditioning. Compact test specimen to seven (7) percent plus or minus one (1) percent air voids. Applicable to Road Class I only.</p> <p>(d) With testing performed at temperatures representing the specified binder grade in the Hamburg rut test, the average rut depth of two (2) mix design test samples is less than the amount shown for the respective Road Classes.</p> <p>(e) Lottman not required if passing Hamburg Wheel Tracker</p>	

PART 3 EXECUTION

3.1 CONSTRUCTION EQUIPMENT

- A. Mixing Plant: Capable of meeting ASTM D995 or UDOT Qualified Plant. Provide:
1. Positive means to determine the moisture content of aggregate.
 2. Positive means to sample all material components.
 3. Sensors to measure the temperature of the mix at discharge.
 4. Ability to maintain discharge temperature of mix.
 5. Capability of maintaining plus or minus five (5) percent tolerance on component percentages in final mix.

6. Ability to document control efforts.

3.2 **INSTALLATION**

- A. [Pavement placement, Section 32 12 16.13.](#)
- B. [Pavement restoration, Section 33 05 25](#)

3.3 **QUALITY CONTROL**

Perform the following:

- A. For all projects, test temperature of mix placed in the transport vehicle at the production plant.
 - a. Reject mixes exceeding the limits identified in the mix design.
- B. For projects requiring testing, collect mix [samples](#) randomly from the plant (from truck or hot-drop) or the field (windrow or behind paver), ASTM D3665.
 1. Sampling bituminous paving mixture, ASTM D979, minimum one sample per sub-lot.
- C. If Quality Control is required by Section 32 12 05S – Project Specific Surfacing Requirements or project documents, submit Quality Control data to the Engineer. Submit data within 3 working days after completion of each day of paving or prior to the start of the next paving day, whichever is sooner.
- D. For projects less than 500 tons, if identified as required by Section 32 12 05S – Project Specific Surfacing Requirements, provide one of the following:
 1. Plant Report; or
 2. Test results for binder content and combined gradation of mix
- E. For projects between 500 and 1500 tons, provide the following:
 1. Combined aggregate gradation in the mix, ASTM D5444.
 2. Binder content in the mix, ASTM D6307.
 3. Maximum Specific Gravity (Rice), ASTM D2041.
- F. For projects greater than 1500 tons, provide the following:
 1. Combined aggregate gradation in the mix, ASTM D5444.
 2. Binder content in the mix, ASTM D6307.
 3. Air voids, ASTM D3203.
 4. Voids in the mineral aggregate, AI MS 2.
 5. Maximum Specific Gravity (Rice), ASTM D2041.
- G. Warm Mix Testing: When rutting or moisture susceptibility tests are

required on warm mix produced at temperatures below 275 deg F, condition the warm mix material before testing for two (2) hours at design mixing temperature plus or minus five (5) deg F per AASHTO R30 (short term aging). The material may be cooled to room temperature before conditioning.

END OF SECTION