

# The Cairns Design Standards

A DOCUMENT OF DEVELOPMENT REQUIREMENTS FOR  
SANDY'S DOWNTOWN DISTRICT



THE  
CAIRNS



# Acknowledgments

## Sandy City Mayor

---

**Kurt Bradburn**

## Sandy City Council

---

**Brooke Christensen, District 1**

**Maren Barker, District 2**

**Kristin Coleman-Nicholl, District 3**

**Chris McCandless, District 4**

**Steve Fairbanks, At-Large**

**Linda Martinez-Saville, At-Large**

**Zach Robinson, At-Large**

## Sandy City Administration

---

**Evelyn Everton** - Deputy Mayor

**Matthew Huish** – Chief Administrative Officer (CAO)

**Shane Pace** – Assistant CAO

**Korban Lee** – Assistant CAO

**Eric Richards** – Communication Director

## Sandy City Planning Commission

---

**Joe Baker**

**Dave Bromley**

**Michael Christopherson**

**Monica Collard**

**Jared Clayton**

**Ron Mortimer**

**Cyndi Sharkey**

**Cory Shupe**

**Jamie Tsandes**

## Sandy City Staff

---

**James Sorensen** – Director, Community Development Department

**Jared Gerber** – Assistant Director, Community Development

**Brian McCuistion** – Planning Director, Community Development

**Mike Wilcox** – Zoning Administrator, Community Development

**Olivia Cvetko** – Zoning Technician, Community Development

**Mike Gladbach** – Director, Public Works

**Ryan Kump** – City Engineer, Public Works

**Tom Ward** – Director, Public Utilities

**Richard Benham** – Engineering Manager, Public Utilities

**Scott Earl** – Director, Parks and Recreation

**Dan Medina** – Assistant Director, Parks and Recreation

**Robert Thompson** – City Attorney

**Darien Alcorn** – Senior Civil Attorney

**Nick Duerksen** – Director, Economic Development/Redevelopment

**Kasey Dunlavy** – Project Manager, Economic Development/Redevelopment

## Participating Agencies/Individuals

---

**Andrew King**

**Blu Line Design**

**Dan Hartman**

**IBI Group**

**Lisa Hartman**

**Mike Coulam**

**Nancy Day**

**Redevelopment Agency of Sandy**

**Rob Wall**

**Utah Transit Authority**

**With a special thanks to Tom Dolan, Scott Bond, and Byron Jorgenson for their vision and leadership**

# Table of Contents

|  |           |  |           |
|--|-----------|--|-----------|
| <b>CHAPTER 1 INTRODUCTION</b>                      | <b>1</b>  | <b>CH 7 FURNISHINGS AND LANDSCAPING</b>        | <b>55</b> |
| 1.1 DOCUMENT SUMMARY                               | 2         | 7.1 FURNISHINGS                                | 56        |
| 1.2 DOCUMENT AUTHORITY                             | 2         | 7.1.2 TREE GRATES                              | 57        |
| 1.3 REQUIRED PROCESS                               | 4         | 7.1.3 MANHOLE COVERS AND SIDEWALK MEDALIANS    | 57        |
| 1.4 THE CAIRNS                                     | 4         | 7.1.4 TRASH RECEPTACLE                         | 58        |
| 1.4.1 "WHERE MOUNTAIN MEETS URBAN"                 | 6         | 7.1.5 BIKE RACK                                | 58        |
|  |           | 7.1.6 BENCHES                                  | 59        |
|  |           | 7.1.8 BOLLARD                                  | 60        |
|  |           | 7.1.7 FENCING                                  | 60        |
| <b>CHAPTER 2 STREETScape STANDARDS</b>             | <b>11</b> | <b>7.2 LANDSCAPING</b>                         | <b>61</b> |
| 2.1 PUBLIC REALM                                   | 12        | 7.2.2 RAISED PLANTERS                          | 62        |
| 2.1.2 VEHICULAR REALM                              | 12        | 7.2.3 IN-GRADE PLANTER                         | 62        |
| 2.1.3 PEDESTRIAN REALM                             | 12        | 7.2.4 FIRE PITS                                | 63        |
| 2.1.4 PEDESTRIAN REALM INTERRUPTIONS               | 13        | 7.2.5 NATURALISTIC PLAY STRUCTURE              | 63        |
| 2.2 PARKSTRIP TREATMENTS                           | 14        | 7.2.6 STEPPING STONES                          | 63        |
| 2.3 DESIGN PRIORITY                                | 17        |  |           |
| 2.4 TRAFFIC-CALMING ELEMENTS                       | 18        | <b>CHAPTER 8 MONUMENTS &amp; WAYFINDING</b>    | <b>65</b> |
| 2.5 ROW ENCROACHMENTS                              | 19        | 8.1 PRIMARY GATEWAY MONUMENTS                  | 66        |
| 2.6 BUILDING FRONTAGE                              | 20        | 8.2 SECONDARY GATEWAY MONUMENTS                | 68        |
| 2.7 COMMERCIAL SPACE PROVISIONS                    | 21        | 8.3 VEHICULAR AND PEDESTRIAN WAYFINDING        | 70        |
| 2.8 DRIVE THRU AND WALK UP WINDOWS                 | 21        |  |           |
|  |           | <b>CHAPTER 9 COMMUNITY SPACES</b>              | <b>73</b> |
| <b>CHAPTER 3 STREETScape DESIGNS</b>               | <b>23</b> | 9.1 OPEN SPACE                                 | 74        |
| STREETScape DESIGN-TYPE 1                          | 26        | 9.1.2 POCKET OPEN SPACE                        | 75        |
| STREETScape DESIGN-TYPE 2                          | 28        | 9.1.3 SQUARE                                   | 76        |
| STREETScape DESIGN-TYPE 3                          | 30        | 9.1.4 PLAZA                                    | 77        |
| STREETScape DESIGN TYPE 4                          | 32        | 9.1.5 NEIGHBORHOOD OPEN SPACE                  | 78        |
|  |           | 9.1.6 BLOCK BREAKS                             | 79        |
| <b>CHAPTER 4 BUILDING MASSING</b>                  | <b>35</b> | <b>CH 10 DEVELOPMENT ENHANCEMENTS</b>          | <b>81</b> |
| 4.1 WHERE MOUNTAIN MEETS URBAN                     | 36        | 10.1 ENHANCMENTS INTENT                        | 82        |
| 4.2 BASE, MIDDLE, AND TOP TREATMENTS               | 37        | 10.2 DEVELOPMENT ENHANCEMENTS                  | 83        |
| 4.3 SPECIALTY USES                                 | 38        |  |           |
| 4.4 BUILDING HEIGHTS                               | 38        | <b>CH 11 UTILITY &amp; LOADING ARRANGEMENT</b> | <b>85</b> |
|  |           | 1.1 LOADING AND UTILITY AREAS                  | 86        |
| <b>CHAPTER 5 BUILDING ARCHITECTURE</b>             | <b>41</b> | 11.1.1 LOADING AREAS                           | 86        |
| 5.1 ARCHITECTURE                                   | 42        | 11.1.2 TRASH AND WASTE DUMPSTERS               | 86        |
| 5.1.2 COMMERCIAL AND HOSPITALITY USES              | 42        | <b>11.2 MECHANICAL AND UTILITY EQUIPMENT</b>   | <b>87</b> |
| 5.1.3 RESIDENTIAL USES                             | 44        | 11.2.1 MECHANICAL AND UTILITY BOXES            | 87        |
| 5.1.4 INSTITUTIONAL, CIVIC, AND ENTERTAINMENT USES | 46        | 11.2.2 WALL MOUNTED EQUIPMENT                  | 87        |
| 5.2 SITE GRADE                                     | 48        | 11.2.3 ROOF MOUNTED EQUIPMENT                  | 87        |
| 5.3 ROOF TREATMENTS                                | 48        |  |           |
| 5.4 LIGHTING                                       | 48        | <b>CHAPTER 12 TERMS DEFINITIONS</b>            | <b>89</b> |
|  |           |  |           |
| <b>CHAPTER 6 PARKING ARRANGEMENT</b>               | <b>49</b> | <b>APPENDIX</b>                                | <b>93</b> |
| 6.1 SURFACE PARKING                                | 50        | APPENDIX A - REQUIRED PROCESS                  | 94        |
| 6.1.2 PHASED DEVELOPMENT SITES                     | 51        | APPENDIX B - PREAPPROVED FURNISHINGS           | 98        |
| 6.2 STRUCTURED PARKING                             | 52        | APPENDIX C - LANDSCAPING                       | 100       |
| 6.2.2 SUB-SURFACE PARKING STRUCTURES               | 53        | APPENDIX D - LIST OF REQUIREMENTS              | 104       |
| 6.3 PARKING ENTRANCES                              | 54        | APPENDIX E - EXAMPLES OF INTERPRETIVE SIGNS    | 114       |



## Chapter 1

# Introduction

---

Document Summary  
Document Authority  
Required Process  
The Cairns  
Where Mountain Meets Urban

The purpose of this design standards document is to create design excellence in The Cairns while providing flexibility to encourage creativity in addressing The Cairns Master Plan goals and objectives. Many of the regulations contained in this document are intended to complement a new theme for approximately 1,000 acres of Sandy City (see pg. 3) – Where Mountain Meets Urban. This area will become the ultimate base camp for the resorts and recreational opportunities to the east of the City. As such, The Cairns will become the premier destination for locals, travelers, and everyone in between who wants to experience the Wasatch Mountains. This document will help ensure long-term vitality to a new downtown in the Salt Lake Valley.

THE  
CAIRNS



## 1.1 Document Summary

This new downtown provides a mixture of uses, vibrant community spaces, and opportunities to live, work, shop, dine, and play in Sandy City. Convenient access to light rail and commuter transit lines will play a pivotal role in getting people to and from this area quickly and affordably. The Cairns Design Standards document, in association with The Cairns Master Plan, will regulate architecture, building massing and arrangement, landscape, streetscape, parking arrangement, and general practices of good urban design to facilitate The Cairns brand and create predictability in quality development practices. Reading and becoming familiar with The Cairns Master Plan and Cairns Design Standards documents during the planning phases of any project in The Cairns is strongly encouraged. Within this document are design standards for site layout, architecture, streetscape designs, parking, landscape elements, loading areas, utilities, and wayfinding. The Cairns Design Standards are required in addition to other applicable laws, ordinances, codes, regulations, and standards.

## 1.2 Document Authority

The Cairns Design Standards (this “document”) are enacted by the Sandy City Council pursuant to and in accordance with the Municipal Land Use, Development and Management Act, Utah Code Ann. §10-9a-101 et seq. and shall be incorporated in and be part of the Development Code of Sandy City. Throughout this document, there are regulations and requirements both in charts and in text. Within these regulations the word ‘shall’ will be used for required elements and ‘should’ for strongly encouraged elements. For a complete list of regulations see Appendix D. Regulations shall be interpreted consistent with the purpose and intent set forth in this document. The Cairns Design Standards are subject to revision by the City in accordance with applicable law, and exceptions to The Cairns Design Standards may be granted in accordance with the procedures set forth in this document.

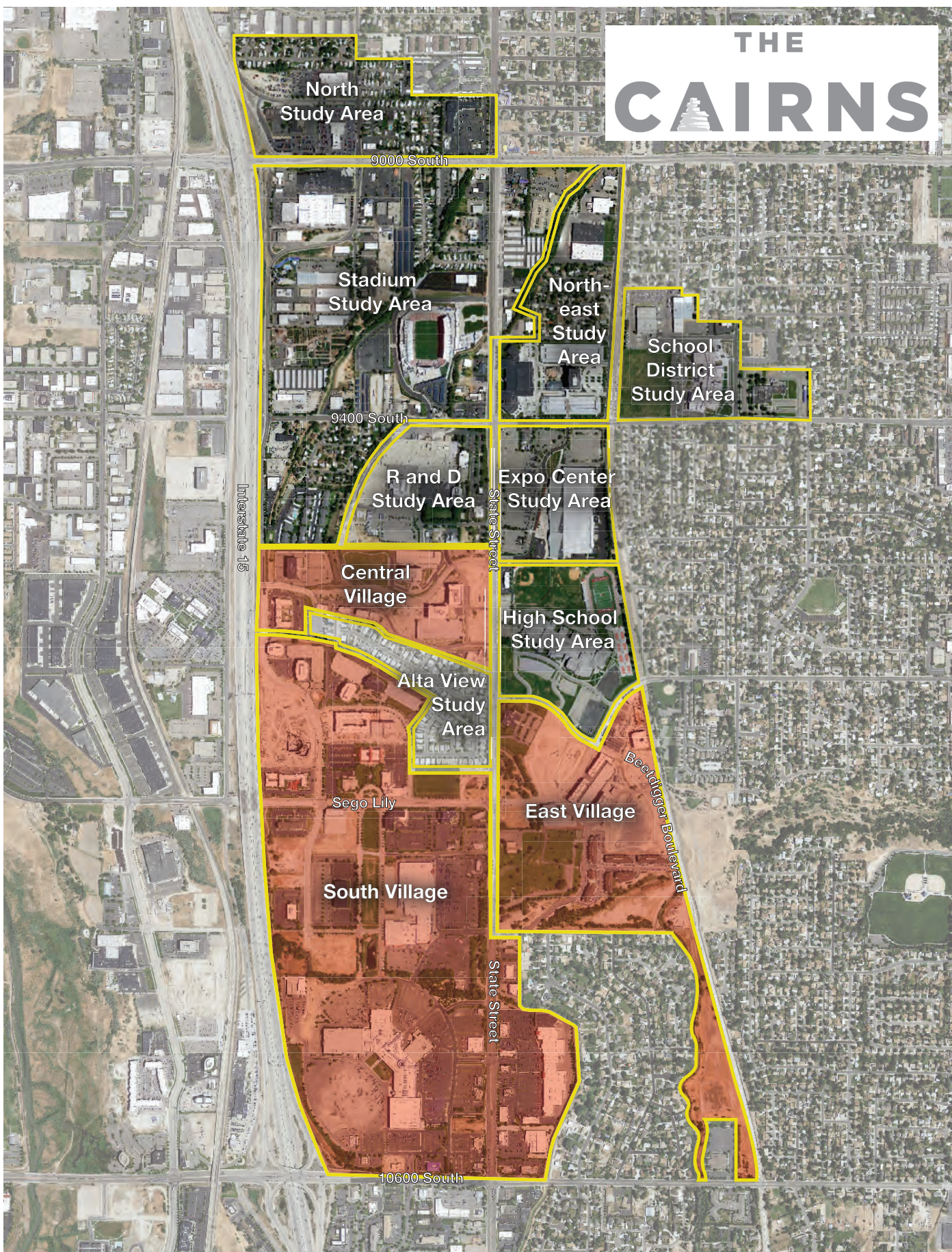

Figure 101 - The Cairns area map with villages and study areas



Figure 102 - View of Sandy City from Lone Peak

## 1.3 Required Process

The following flow chart (figure 103) explains the required process for development in The Cairns. This process is designed to limit the number of submittals and reviews required for project approval. It is not the intent of the City to design each project, but to ensure that the requirements of this document are understood and adhered to. The earlier in the design process the City can be involved, the less likely that the review process will be drawn out due to compliance issues.

The dark blue arrows in figure 103 are intended to illustrate the quickest path to approval. The smaller blue arrows indicate extra meetings and reviews, which consequently also represent additional time. Extra steps should only be necessary if exceptions to The Cairns Design Standards are requested, major design issues are discovered, or redline comments are not timely addressed. In a streamlined scenario, a project could be reviewed and approved in a 2-4 month window. For a complete explanation of this development process, please refer to appendix A in this document.

## 1.4 The Cairns

The Cairns is a downtown for Sandy City and a “base camp” for recreation in the Cottonwood Canyons. The Cairns is a mixed-use community that offers opportunities to live, work, shop, dine, and recreate. It is a regional destination for people looking for local restaurants, world-class entertainment, a vibrant night-life, and unique shopping opportunities.

The Cairns, which consists of approximately 1,000 acres has been divided into 10 villages and study areas (see figure 101 on pg. 3). Existing villages have been master planned and are ready for redevelopment. It is intended that through the development, redevelopment, and adherence to the standards of this document, The Cairns will become the premier destination for the patrons of the Wasatch Mountain resorts by providing critical services to the resort industry.

# THREE-PHASE SITE DEVELOPMENT PROCESS

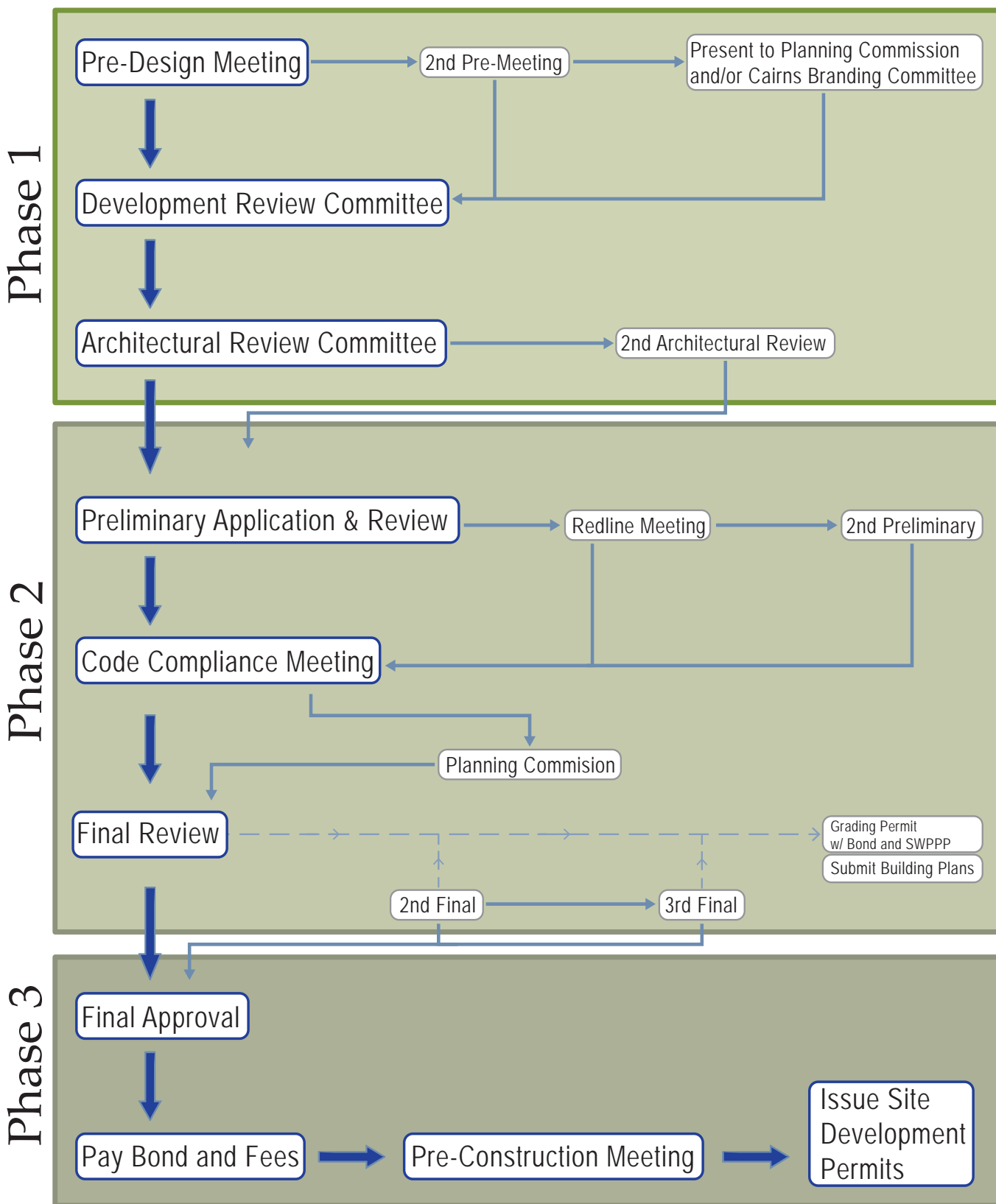

Figure 103 - Cairns area Three-Phase Site Development Process

## 1.5 “Where Mountain Meets Urban”

The Where Mountain Meets Urban theme is intended to create a vision for the design process of any new development or redevelopment. In simple terms, this theme encourages the use of mountain forms and features like canyons, valleys, meadows, streams, cliffs, ledges, forests, rocks, and peaks. These elements of the natural environment should be the inspiration for all features of the urban landscape. Elements such as street walls, pathways, nodes, enclosures, landscape, building massing, architectural styles, and materials provide opportunities to implement these “natural” elements and are the critical framework of development in The Cairns. Finding the right balance between “mountain” and “urban” will be the unique design opportunity for each project.

The following four elements of the Wasatch Mountains should be used in an urban context to connect the two environments.

- a. Forest: shade, shelter, habitat, aroma, texture, enclosure, sound, edges, grove, and canopy
- b. Meadow: open, flexible, edges, relax, color, and passable
- c. Stone: foundation, strata, tectonic, permanence, escarpment, ledge, cliff, boulder field, and fissure
- d. Water: life, movement, cool, sound, eddy, seep, cut bank, river, stream, and creek



Figure 104 - Visual Comparison of an urban forest and the natural environment



Figure 105 - Visual Comparison of an urban meadow and a natural meadow



Figure 106 - Visual Comparison of stone in an urban and natural setting



Figure 107 - Visual Comparison of a man-made water feature and a natural body of water

1.5.1 FOREST

Wild, peaceful, and dynamic; forests are a vital thread in the fabric of the mountains; they define edges for meadows, prevent erosion, cover slopes with texture and color, and provide refuge for wildlife. In the sanctuary of a forest, rays and gradients of light penetrate the canopy as we are dwarfed and humbled by the mass and verticality of pines and aspens. The aura of a forest can exist on our streets and in our parks through appropriate planning and design. Whether through organic groupings or formal patterns, producing the feel of a forest should be the primary concern.

Figures 108-114 are examples of trees framing a view and defining paths in the wild, and how a similar form can be conveyed in the streetscape as an “urban canyon”.

FOREST FORMS & ELEMENTS

Below is a partial list of some forest elements that can influence the design of urban forests in The Cairns. While the images are not meant for duplication, they are good illustrations of how using nature provided principles and combining trees with other mountain elements and forms will help create the ambiance of a forest, while simply placing a few trees in an urban setting will not.

- a. Clustering Tree Placement
- b. Filtered Light
- c. Canopy
- d. Undergrowth
- e. Wilderness
- f. Evergreen
- g. Leaves
- h. Branches
- i. Fallen trees/logs



Figure 108 - Natural mountain forest



Figure 109 - Nature defining a path



Figure 110 - Landscaping defining a path



Figure 112 - Urban clustering tree placement



Figure 111 - Urban filtered light



Figure 113 - Urban canopy



Figure 114 - Urban wilderness

## 1.5.2 MEADOW

Soft, open, and accessible; mountain meadows offer relief from the rugged terrain and thick brush of the hillsides, an area for wildlife to gather, feed, and rest. Grasses and wildflowers stretch like a carpet over the meadow soil with trees and shrubs scattered where conditions are right. The ambiance of a meadow can be carried into any urban environment of choice with proper selection and distribution of vegetation, as well as spatial definition.

Figures 115-121 are examples of how edges, spatial qualities, and natural uses of a mountain meadow can be carried into publicly used open spaces.

### MEADOW TYPES & ELEMENTS

Below is a general list of meadow elements and types that can be used to influence meadow-like spaces and landscapes in The Cairns. Note that a meadow feel can and should be applied to many pieces of the cityscape and should not be restricted to wide open spaces.

- a. Alpine Meadow
- b. Lawns
- c. Middle ground
- d. Hillside
- e. Wet Meadow
- f. Desert Meadow
- g. Wooded Meadow
- h. Prairie
- i. Flora + Fauna
- j. Edges
- k. Grasses + Wildflowers
- l. Wildlife
- m. Open Space



Figure 115 - Natural mountain meadow



Figure 116 - Wildlife enjoying a meadow



Figure 117 - Pedestrians enjoying an urban meadow



Figure 118 - Urban example of an alpine meadow



Figure 119 - Urban Grasses



Figure 120 - Urban prairie

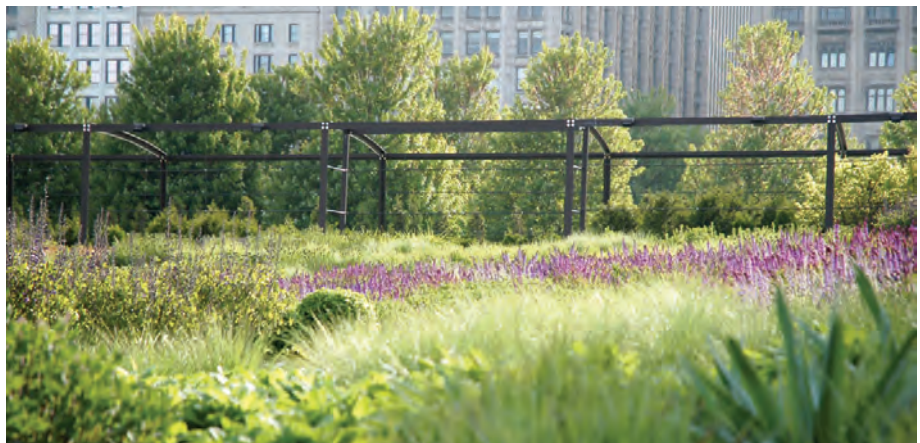

Figure 121 - Urban edge

### 1.5.3 STONE

Rugged, permanent, and gritty; stone is visually indispensable for achieving a mountain aesthetic and feel. In the wilderness, stone features act as landmarks, barriers, shelters, look out points, a window into the geological history of the area, and much more. Nearby canyons are known for their breathtaking views of mineral and stone contrasting against the soft and organic vegetation, and can be utilized as a source of inspiration. The introduction of stone into the urban environment of The Cairns should be both tactful and bold.

Figures 122-127 are examples of a natural setting with an outlook point and views of featured elements, and how it could be transferred into a city environment.

#### STONE FORMS & ELEMENTS

Below is a starter list of natural stone elements that can be represented in the cityscape. The matching images are not so much design suggestions as they are thought-starters for ways that stone forms can be creatively interpreted into an urban setting.

- a. Scree Fields
- b. Boulders
- c. Crag/Cliff/Precipice
- d. Canyon
- e. Stone Run or Moraine
- f. Tor (Natural Cairn)
- g. Escarpment
- h. Outcrop
- i. Mesas + Buttes
- j. Quarry



Figure 122 - Lone Peak rocks overlooking the Salt Lake Valley



Figure 123 - Natural rock elements



Figure 124 - Urban rock elements



Figure 125 - Urban scree field



Figure 126 - Urban canyon



Figure 127 - Urban outcrop

## 1.5.4 WATER

Flowing, vibrant, and limited; water attracts life, in natural and urban environments alike. People enjoy observing, hearing, interacting with, and gathering around water. From high-mountain snow fed lakes and streams to valley ponds and beaver dams, the Utah wilderness is flowing with liquid inspiration. Water features, whether for aesthetics, recreation, function, or all of these, should be either interpretive or literal reproductions of natural mountain water systems and features, innovatively integrated into the urban aesthetic.

Figures 128-134 are examples of natural interactions, elements, and functions that occur at a body of water both in natural and urban settings. Instances of such an experience being placed into an urban setting with visual and recreational appeal adds to the Where Mountain Meets Urban feel.

## WATER SYSTEMS & ELEMENTS

Below is a starter list of water systems found in nature that can inspire urban water features. The corresponding images are examples of thoughtful water feature design and are meant to provoke creative thought processes and design results.

- a. Canyons
- b. River
- c. Lake
- d. Tributary/Stream
- e. Mist/Vapor
- f. Spring
- g. Marsh
- h. Waterfall
- i. Dry river beds creating form



Figure 128 - Bell Canyon Reservoir



Figure 129 - Bears playing on rocks and in water



Figure 130 - Pedestrians playing on rocks and in water



Figure 131 - Urban appearance of a river



Figure 132 - Urban example of a stream



Figure 133 - Urban appearance of a spring



Figure 134 - Urban example of a waterfall

## Chapter 2

# Streetscape Standards

---

Public Realm  
Parkstrip Treatments  
Design Priority  
Traffic-calming Elements  
ROW Encroachments  
Building Frontage  
Commercial Space Provisions  
Drive Thru and Walk Up Windows

The following concepts and terms need to be understood to fully comprehend the requirements of this document. These streetscape standards provide a list of best practices, or principles of success, that give guidance on how best to implement these practices. Many of these concepts and terms are just explanations, while some of them will contain regulations pertinent to a project.

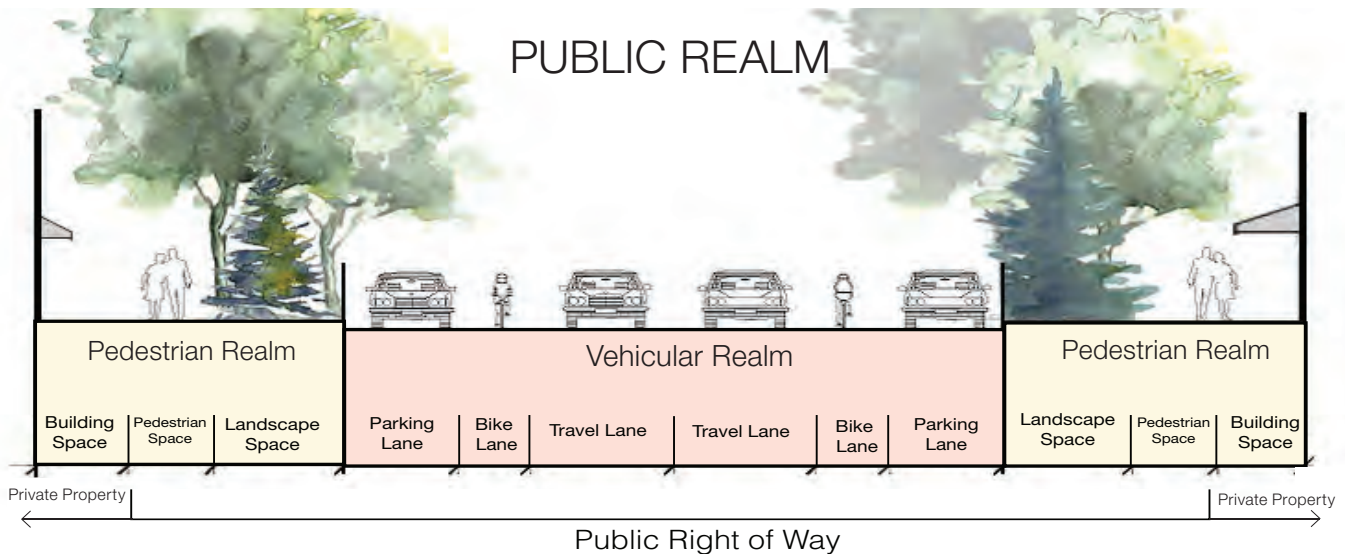

Figure 201 - Graphic of the public realm and its components

## 2.1 Public Realm

The public realm is a term used to reference the entire area between buildings along a right-of-way (ROW), pedestrian mew or alley, or the full width of the ROW where there is not a building(s). The land may be publicly or privately owned but will be visually “public” due to its location, purpose, and visibility. The public realm consists of two sub-realms, vehicular, and pedestrian, which each serve a unique purpose in creating inviting places. These areas will ultimately determine the success and enjoyment of residents and visitors to The Cairns. The public realm will vary depending on a specific streetscape design-type. Within this chapter are general standards and principles, whereas the specific details are located in chapter three of this document.

### 2.1.1 PRINCIPLES OF SUCCESS

- a. Carefully design each realm to accommodate elements that ensure all modes of transportation are safe and convenient.
- b. Provide a variety of connections that distribute traffic and make it easier to navigate The Cairns.
- c. Provide a variety of repeating elements architecturally on buildings and with raised planters and furnishings to create a pedestrian (human) scale.
- d. Make this area inviting with a variety of small and large spaces, landscape to soften edges and buffer uses, and street fronting uses that puts “eyes on the street”.

### 2.1.2 VEHICULAR REALM

This area is measured between the front face of curbs on a street and includes on-street parking, bike lanes, transit lanes, and vehicular lanes, depending on the street. This realm should accommodate the safe and efficient circulation of motorized vehicles, mass transit, and bicycles. Multi-modal streets are encouraged wherever possible. Design elements that control traffic speeds should be implemented wherever possible. The design for this realm shall comply with Sandy City Specifications and Details for Municipal Construction and the Manual on Uniform Traffic Control Devices (MUTCD).

### 2.1.3 PEDESTRIAN REALM

The pedestrian realm consists of three spaces, two public and one private, which are all important in creating a successfully designed street. This realm is measured between the face of buildings and the face of the adjacent curb. The safe and enjoyable circulation of pedestrians is the primary objective of this realm.

#### LANDSCAPE SPACE

The landscape space is a softscape or hardscape area between the front face of curb and the pedestrian space (usually indicated by a change in material and/or edge of a sidewalk). This area should include a variety of landscape treatments such as a parkstrip, outdoor dining, seating, street lighting, and other furnishings that create a sense of separation between travel methods. Treatments should be intermittent.

PEDESTRIAN SPACE

The pedestrian space is an area designated for the movement and circulation of pedestrians. This area is located between the landscape space and building space. Widths of this area may vary but the clear walkway shall never be less than eight feet. Where possible, the pedestrian space should have a small meander, created by a variety of parkstrip and building elements that encourages a pedestrian to not walk in straight paths. The full width of this area may meander in and out of the public ROW.

BUILDING SPACE

The building space is between the pedestrian space and the front face of the building. This space is provided to display merchandise, private landscaping, and temporary signage, enhance entryways, provide outdoor seating or dining, or provide a stoop for residential uses. The building space should activate the street and create visual interest for those walking, biking, or driving by. This space should not be less than six feet wide.

////////////////////  
**2.1.4 PEDESTRIAN REALM INTERRUPTIONS**

Breaking up the streetscape design patterns with deliberately designed “interruptions” adds complexity and visual interest to The Cairns streetscape experience. Interruptions can be achieved through a combination of design details. Some details in the pavement include paving material, paving articulation, and paving color. Other design details that create interruptions can include: custom furnishings, branding and wayfinding, LID elements, vegetation, public art, and/or plant material that varies from the consistent design of the streetscape.

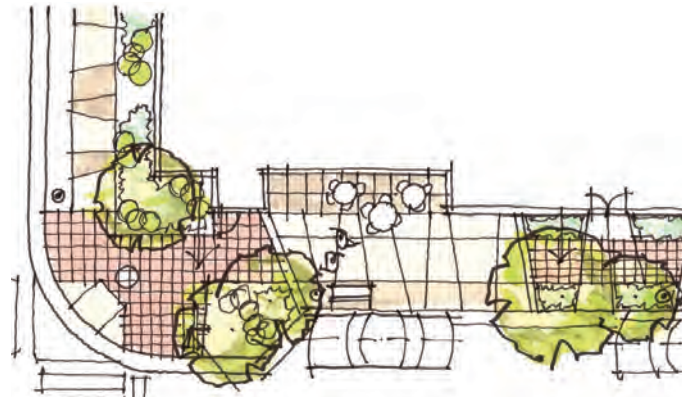
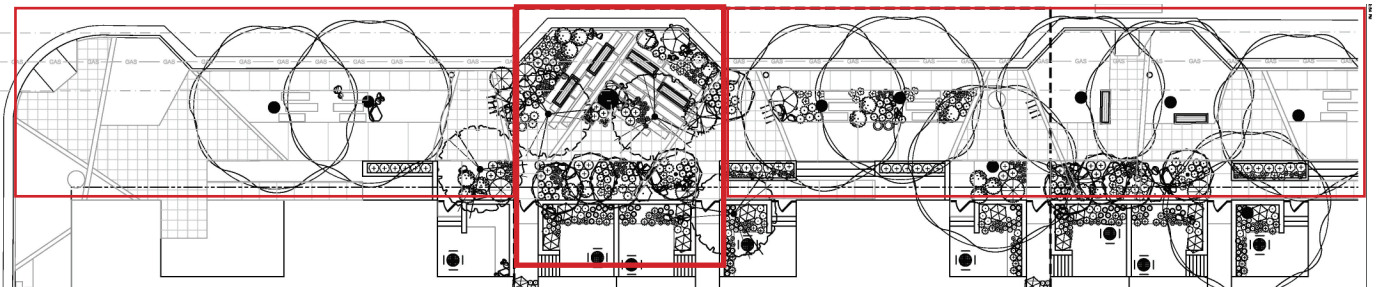

Figure 202 - Corner scenario streetscape design



Figures 203 and 204 (top left and right) - Images of streetscapes with different paving materials, different types of “interruptions” and a meandering walkway. Figure 205 (bottom) - A hypothetical streetscape showing all 3 Pedestrian spaces in a Combination-streetscape design.

## 2.2 Parkstrip Treatments

Parkstrips are one of the design elements of the landscape space. These areas can be formal, informal, or a combination which will dictate the planting, shape, and spacing. The type of parkstrip treatment required for each street will be detailed in chapter three of this document. They are intended to soften street edges and provide a critical buffer between the pedestrian activities of the pedestrian realm and the vehicular activities of the vehicular realm. Parkstrips provide one of the best opportunities to implement mountain landscape themes into the public realm of The Cairns. The parkstrips implemented in The Cairns are essential to the Where Mountain Meets Urban design theme and should soften the urban setting. The use of native plants is encouraged to increase this vision; annuals, perennials, grasses, and small flowering shrubs are encouraged in informal parkstrip settings (see chapter seven and the plant list in Appendix C of this document).



Figure 206 - Parkstrip used to soften the street edge



Figure 207 - Artistic example of an informal parkstrip

### 2.2.1 PRINCIPLES OF SUCCESS:

- a. The use of native and/or drought tolerant plant species is encouraged.
- b. Parkstrip treatments should be an extension of landscape treatments in the building space.
- c. Trees and other landscape materials should be planted in clusters where possible.
- d. Raised planter beds and planter boxes are encouraged.
- e. Traditional parkstrip treatments of a continuous width of sod planted areas should be used sparingly.
- f. Parkstrips should be strategically designed to meander the pedestrian space.
- g. Parkstrips should provide separation between on-street parking and landscape treatments that would otherwise limit pedestrians from exiting a vehicle.
- h. Parkstrips should be planted after streetlights are installed or planned.
- i. Parkstrips should be maintained by a drip irrigation system.
- j. Parkstrips should include storm water quality and flood control elements. Grade hard surfaces and streets to depressed medians with curb cuts for storm water quality treatment and rainwater harvesting.



Figure 208 - Example of grasses and shrubs in the parkstrip

**2.2.2 FORMAL TREATMENT REQUIREMENTS (SEE FIGURE 211):**

- ❑ There shall be a minimum of one street tree for every 35 feet of street frontage (from the plant list in this document or as approved by the Parks and Recreation Department)
- ❑ Trees shall have a two-inch caliper at the time of planting
- ❑ There should be an organized tree planting pattern that creates a consistent tree canopy
- ❑ Tree types should alternate between two tree species (from the plant list in this document or as approved by the Parks and Recreation Department)
- ❑ 15% of the parkstrip should include raised planter(s)

**2.2.3 INFORMAL TREATMENT REQUIREMENTS (SEE FIGURE 212):**

- ❑ Street trees should be planted in clusters: four-foot minimum separation between trees
- ❑ At least 40% of parkstrip area shall include softscape treatment
- ❑ Softscape areas shall be a minimum of 70% plant material
- ❑ Planting areas may have an irregular shape
- ❑ Parkstrips shall include at least three different trees species (from the plant list in this document or as approved by the Parks and Recreation Department)
- ❑ All trees with a canopy that extends beyond the planter edge should have a minimum 25-foot mature height
- ❑ 10% of the parkstrip should include raised planter(s)
- ❑ Trees shall have a two-inch caliper at the time of planting
- ❑ Parkstrips should include storm water quality and flood control elements. Grade hard surfaces and streets to depressed medians with curb cuts for storm water quality treatment and rainwater harvesting

**2.2.4 COMBINATION TREATMENT REQUIREMENTS (SEE FIGURE 213):**

- ❑ Street trees shall be planted with a combination (both) of the Formal and Informal treatments (see requirements for those treatments)
- ❑ 10% of the parkstrip should include raised planter(s)
- ❑ There shall be a minimum of one street tree per 45 feet of street frontage (from the plant list in this document or as approved by the Parks and Recreation Department)
- ❑ Trees shall have a two-inch caliper at the time of planting



Figure 209 - Example of a formal parkstrip



Figure 210 - Street trees as a traffic-calming element

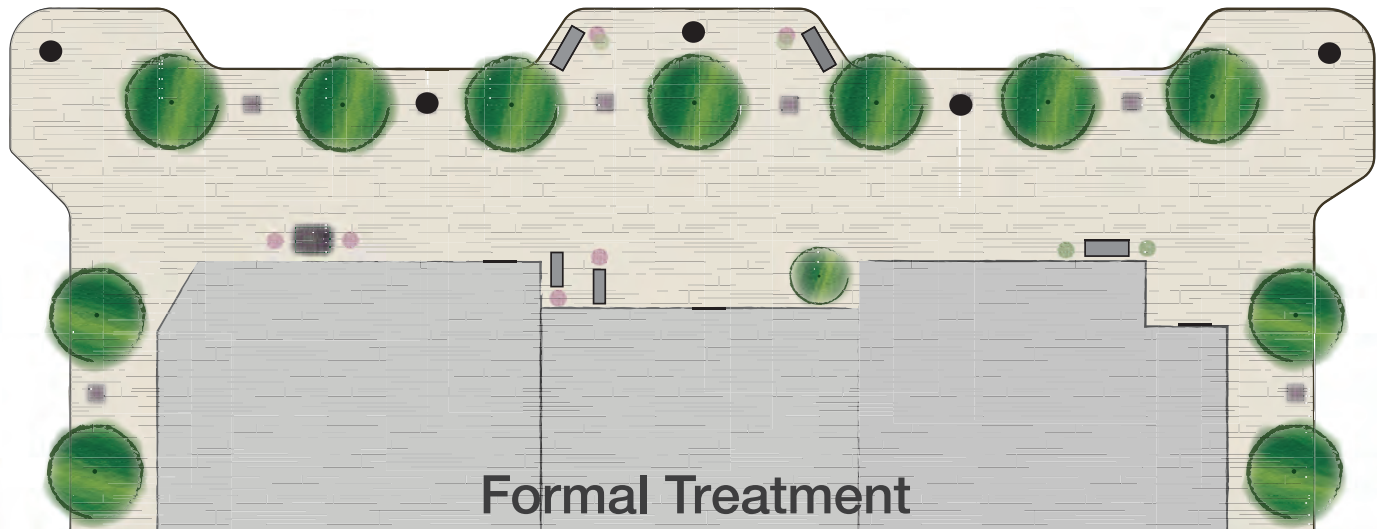

Figure 211 - Rendering of a typical formal parkstrip treatment



Figure 212 - Rendering of a typical informal parkstrip treatment



Figure 213 - Rendering of a typical combination parkstrip treatment

## 2.3 Design Priority

The design priority of a street is intended to apply to the spaces where vehicles and pedestrians interact. In all cases, vehicular and pedestrian realm areas should receive the same high-quality design attention. The chart below explains requirements associated with this design criteria. The design priority will vary from street to street depending on-streetscape design-type outlined in chapter three of this document.



Figure 214 - Rendering of a street with a pedestrian priority

### 2.3.1 PRINCIPLES OF SUCCESS

- a. Design treatments should consider the most vulnerable user of any particular space, including pedestrians, vehicles, cyclists, etc.
- b. Design treatments should implement certain traffic-calming measures as feasible, including bulb-outs, painted crosswalks, platforms, landscape, etc.
- c. Design treatments may be used to visually communicate how a space is used and who is the primary user. Use different paving materials, colors, bollards, etc.



Figure 215 - Example of a street with shared pedestrian and vehicular priority

### 2.3.2 DESIGN PRIORITY REQUIREMENTS

- Each site shall comply with the requirements in Table 201 for their assigned design priority according to chapter 3 of this document

| DESIGN PRIORITY REQUIREMENTS |   |   |   |   |
|------------------------------|---|---|---|---|
| DESIGN ELEMENTS              | PEDESTRIAN                                  | SHARED                                      | VEHICULAR                                   | EXPLANATION   |
| Crosswalk Treatment          | Stamped & colored concrete                  | Stamped & colored concrete                  | Thermal plastic                             | Standard applies to any public or private street crossing.                        |
| Crosswalk Width              | 6 feet                                      | 8 feet                                      | 6 feet                                      | Measured between the inside of the painted lines                                  |
| Driveway Crossings Treatment | Raised                                      | Raised                                      | Stamped & colored concrete                  | “Raised” denotes crossings that are raised to the level of the adjacent sidewalk. |
| Driveway Crossing Width      | 6 feet                                      | 6 feet                                      | 6 feet                                      |   |
| Pedestrian Refuge Required   | Yes (if the pedestrian crossings > 38 feet) | Yes (if the pedestrian crossings > 38 feet) | Yes (if the pedestrian crossings > 48 feet) | Crossings are measured from face of curb to face of curb at the crosswalk.        |
| Bulb-Outs                    | Yes   | Where on-street parking exists              | Where on-street parking exists              | Bulb-outs should extend the full width of any on-street parking.                  |

Table 201- Shows requirements that shall be implemented for design elements under different design priorities

## 2.4 Traffic-calming Elements

Traffic-calming elements remind vehicles and pedestrians that a space is shared. These elements should make drivers aware of possible pedestrian traffic in vehicular spaces and provide pedestrians a designated way to cross vehicle paths. Traffic-calming elements may also be elements that encourage drivers to move more slowly through an area.

**Bulb-outs:** bulb-outs are areas of sidewalks extended into the roadway to provide shorter pedestrian crossings, to break up on-street parking and to calm traffic.

**Pedestrian Island or Refuge:** pedestrian islands are also known as “safety islands, pedestrian safety islands, refuge islands, and pedestrian refuge areas”. These spaces are raised islands in the center of the street adjacent to a crosswalk to provide pedestrians an “island” in the road to make crossing distance shorter or to provide a comfortable waiting area if a street cannot be crossed in the allotted time. These areas should include curbs, bollards, landscaping, or other elements to protect pedestrians from traffic as they wait to cross.

**Street Trees:** street trees are mature trees planted close to a vehicular ROW. They enclose the street and make it feel tighter, which naturally slows traffic.

**Crosswalks:** crosswalks in The Cairns should help build the brand and encourage the Where Mountain Meets Urban theme. Figure 216 demonstrates a couple creative ways crosswalks can create a brand for the area.

**Intersections:** intersections are of significant importance as they are areas of high visibility that often serve as a gateway into The Cairns. They should be designed as small plazas to create a sense of place. Figures 217 and 218 show design scenarios where visitors can be drawn into the space through a themed crosswalk.

### 2.4.1 CHECKLIST OF REQUIREMENTS:

- ❑ Crosswalks shall have a defined edge according to street code requirements. Borders may be added to designs as needed
- ❑ In locations where a building is present at the corner, there shall be a specialty paver area of 500 square feet or more in size (see figure 218)
- ❑ In locations with a monument at the corner, there shall be a specialty paver area of 200 square feet or more in size (see figure 217)
- ❑ Crosswalks shall offer a route from the intersection to either the building entrance or a point of interest

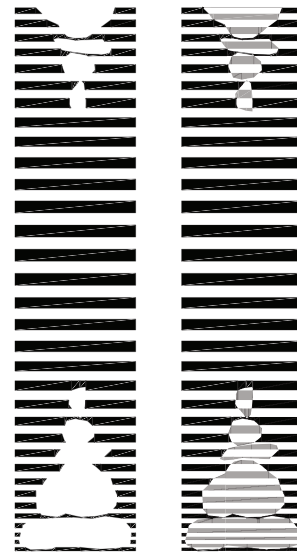

Figure 216 - Unique crosswalk designs for The Cairns

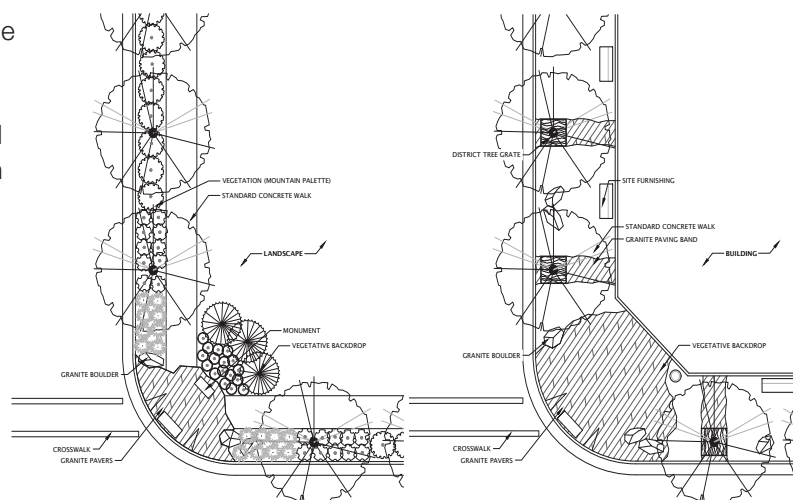

Figure 217 - Intersection design with monument

Figure 218 - Intersection design near building or point of interest

## 2.5 ROW Encroachments

Right-of-way (ROW) encroachments should be limited, however, certain elements will be allowed to encroach into the ROW to improve the human scale of buildings and activate the public realm. All ROW encroachments, including permitted ones, are subject to review and removal if it is determined necessary for health, welfare, safety, if the building or business has unresolved code enforcement issues, or if the City needs the space for other purposes. Permitted encroachments include the following:

- a. Temporary outdoor displays (shall be removed at the end of each day)
- b. Temporary signage (shall be removed at the end of each day)
- c. Outdoor dining areas (shall maintain clear walkway)
- d. Permanent projecting wall signs as long as they are at least eight feet above walkways
- e. Private street furnishings intended for public use
- f. Building footings, or other sub-grade infrastructure (as approved by the City Engineer)
- g. Balconies and awnings (as approved by the Community Development Director)



Figure 219 - Outdoor dining as a right of way encroachment



Figure 220 - Outdoor Displays as a right of way encroachment



Figure 221 -Outdoor Signage as a right of way encroachment

## 2.6 Building Frontage

Building Frontage is a term that references the bottom two stories or 20 feet of a building along a ROW. Frontages often include the adjacent building space, pedestrian space, and landscape space to create an activated and cohesive public realm. Minimum and maximum setbacks for all buildings will be determined by the streetscape design-type (see Chapter 3). Corner lots will have two building frontages (a primary and a secondary) and possibly two sets of streetscape design-type requirements to follow. Each frontage shall follow the requirements in the public realm for the streetscape design-type it faces (the interior of a project will be governed by the project's primary frontage).

The purpose of this section is to encourage interaction with buildings and the streets, pushing building entrances close to the pedestrian space to activate the public realm.

### 2.6.1 CHECKLIST OF REQUIREMENTS:

- All buildings in The Cairns shall have frontage on at least one public or private ROW or mew.
  - a. Primary frontage:
    - The primary frontage shall be the frontage of a building on the smallest numbered streetscape design-type, types 2-4, where two or more frontages exist
    - The primary frontage shall be the frontage that shall satisfy the ground floor commercial requirement (see Chapter 3)
    - The primary frontage shall include the primary entrance to the building for streetscape design-types 2 and 3
    - At least 70% of either the facade of the building or a community gathering space (see Chapter 9) shall be built within five feet of the minimum setback for the applicable streetscape design-type (For restaurant and entertainment uses, outdoor seating and dining may count towards 70%)
  - b. Secondary frontage:
    - The secondary frontage shall be the frontage of a building on the larger numbered streetscape design-type, where the types are different
    - At least 70% of the facade of the building or community gathering space (see Chapter 9) shall be built at or closer than the maximum setback for the applicable streetscape design-type (For restaurant and entertainment uses, outdoor seating and dining may count towards 70%)



Figure 222 - Example of a building with a strong primary frontage

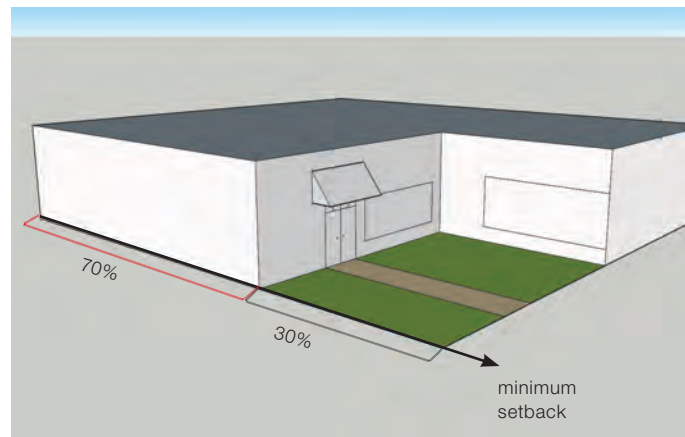

Figure 223 - Graphic showing example of how to implement the 70 % rule

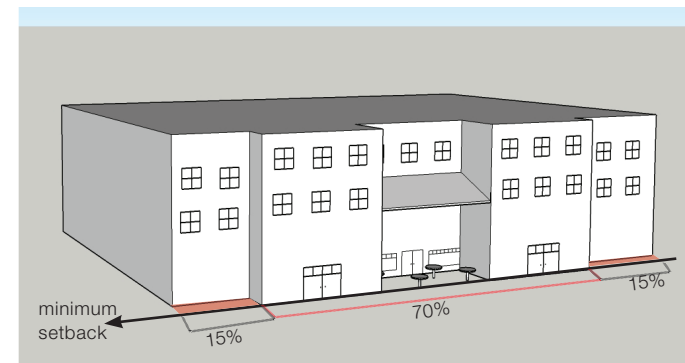

Figure 224 - Graphic showing example of how to implement the 70 % rule

## 2.7 Commercial Space Provisions

### FLEX-COMMERCIAL SPACE

When it is not economically viable to build commercial space consistent with the requirements of this document, commercial space may be designed as flex-commercial space. This allows spaces to be used for an economically feasible purpose immediately while preserving the ability to convert to commercial uses when such use becomes economically viable.

Flex-Commercial Space shall be minimally designed with all of the following elements:

- a. All necessary venting, electrical, and plumbing for a standard restaurant user
- b. Minimum ten-foot ceilings
- c. Street entrances for pedestrians

### TRANSFER OF COMMERCIAL SPACE

As a second option for relief from minimum commercial requirement required commercial space may be transferred to another building or project on the same street or within 300 feet of the building. Transfer of commercial space shall require all of the following:

- ❑ Commercial space shall be transferred on at least a 1:1 square foot ratio
- ❑ Commercial space shall be transferred to another building or project on the same street (up to 1,000 feet away) or to another building within 300 feet as long as the new project is in The Cairns
- ❑ The transferred commercial space shall not be built as flex-commercial space
- ❑ The transferred commercial space shall be constructed simultaneously with the proposed project
- ❑ Commercial space shall not be transferred away from any streetscape design-type 2 street but may be transferred to a streetscape design-type 2 street

## 2.8 Drive Thru and Walk Up Windows

Drive-thru's should be limited in The Cairns area to promote a more pedestrian friendly atmosphere. Where drive-thru's are permitted, they should be screened with buildings and landscaping so they are not obviously visible to pedestrians. Though drive-thru's should be limited, walk-up windows are encouraged in pedestrian friendly spaces to promote pedestrian activity.

### 2.8.1 CHECKLIST OF REQUIREMENTS

- ❑ Where permitted, drive thru windows and lanes shall be behind buildings or heavily screened to eliminate or minimize the view from the public realm
- ❑ No more than one drive thru lane shall be allowed for any one business
- ❑ Walk-up windows are allowed and encouraged in type 1 and 2 streetscape design-types (see chapter 3)

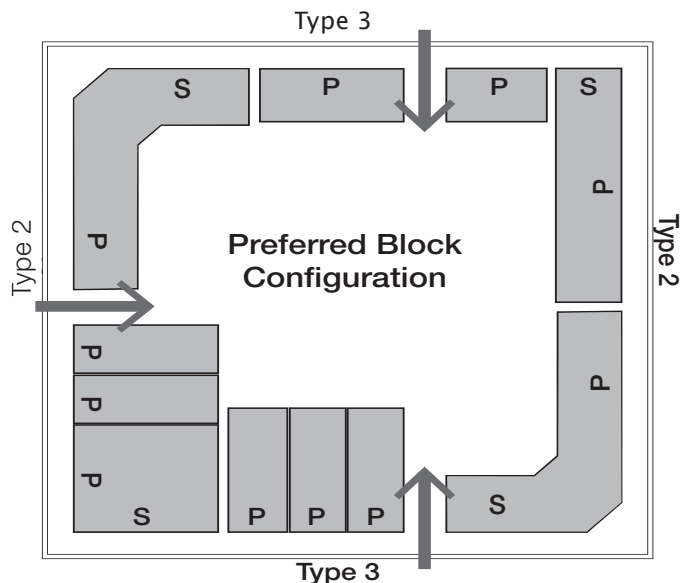

Figure 225 - rendering of a preferred block configuration in The Cairns  
 P shows a primary frontage  
 S shows a secondary frontage



## Chapter 3

# Streetscape Designs

---

Street Design-Type Classification Map  
Streetscape Design-Type 1 Chart  
Streetscape Design-Type 2 Chart  
Streetscape Design-Type 3 Chart  
Streetscape Design-Type 4 Chart

These streetscape design-type standards complement the existing standards for thoroughfares in Sandy City. Road and lane widths shall comply with the Sandy City Specifications and Details for Municipal Construction. Pedestrian and landscape spaces shall be a minimum of 14 feet (measured from the top back of curb) on all streets. The design of the public realm shall be based on these regulatory streetscape design-type charts.

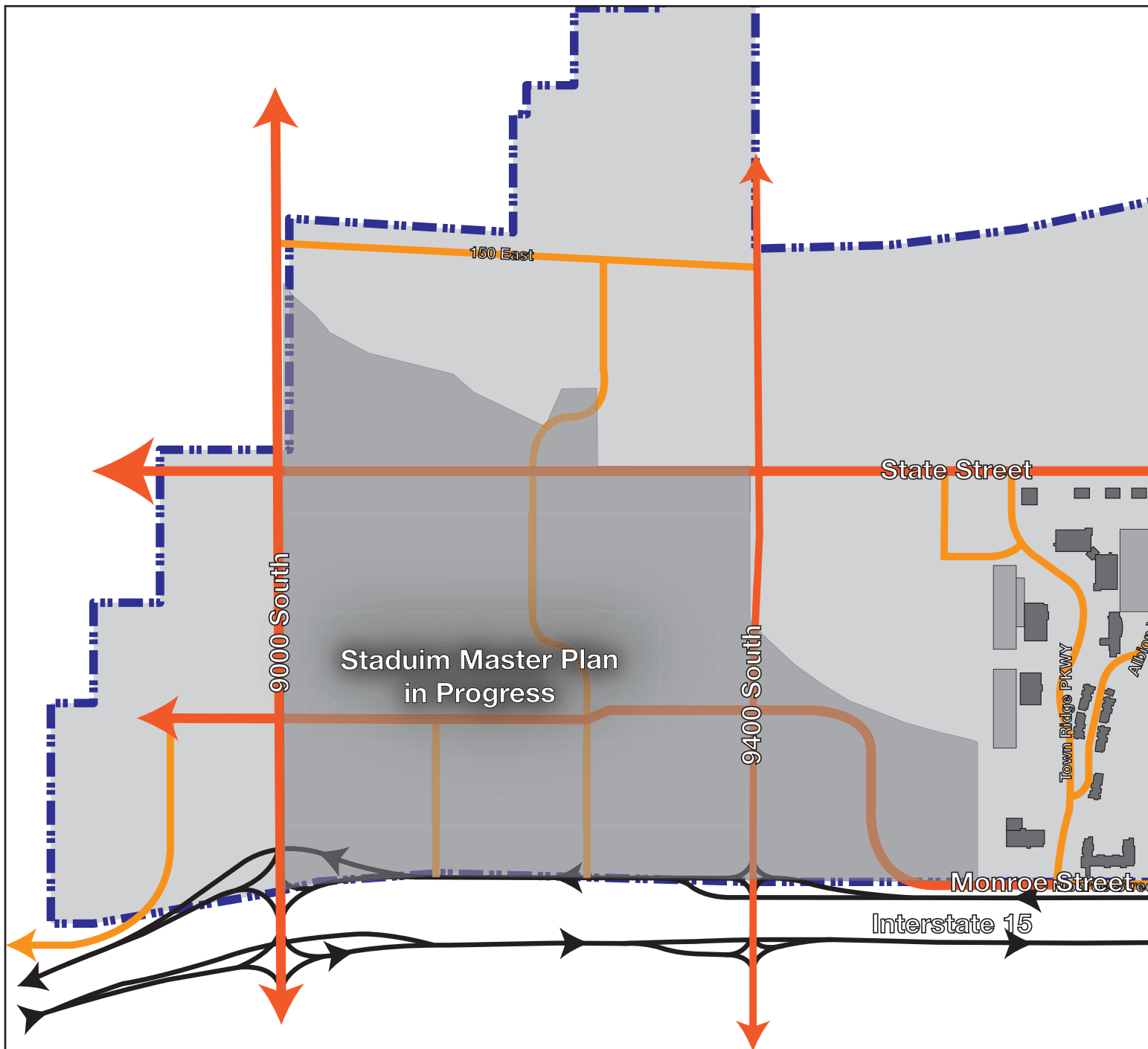

**STREETSCAPE DESIGN-TYPE 1**

East Village Mew

**STREETSCAPE DESIGN-TYPE 2**

Midvillage Boulevard  
 10080 South  
 Centennial Parkway  
 10200 South

**STREETSCAPE DESIGN-TYPE 3**

Sego Lily Drive  
 Beetdigger Boulevard  
 Creek Run Way  
 Civic Center Drive  
 Town Ridge Parkway

See in Cairns Master Plan as:

Streetscape Design-Type 1 = Pedestrian Mew and Mid-block Break  
 Streetscape Design-Type 2 = Residential, District, RDE Streets

Streetscape Design-Type 3 = Collector and Distributor Streets  
 Streetscape Design-Type 4 = Arterial and Boulevard Streets

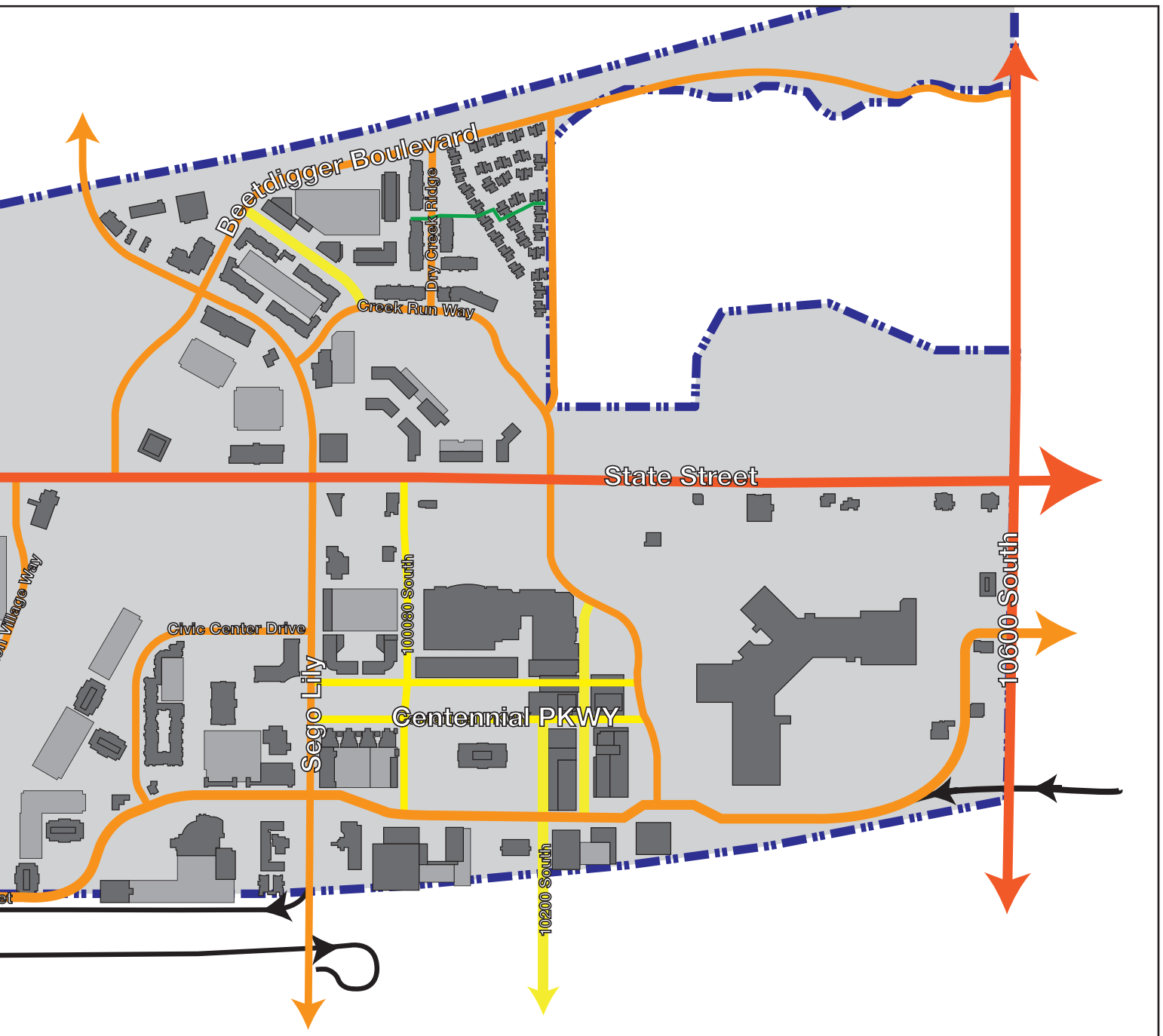

Figure 301 - Cairns Streetscape Design-Type map updated 2017

**STREETSCAPE DESIGN-TYPE 3 cont.**

- Albion Village Way
- Stadium Way
- Dry Creek Ridge Lane
- Harrison-street
- 10200 South (west of State)
- Monroe

**STREETSCAPE DESIGN-TYPE 4**

- State Street
- 10600 South
- 9000 South
- 9400 South

## STREETSCAPE DESIGN-TYPE 1

See in master plan as = pedestrian mew, mid-block breaks

| STREETSCAPE ELEMENT  | REGULATION THAT SHALL BE IMPLEMENTED  |  | EXPLANATION   | REFERENCE                         |
|--|---|--|---|-----------------------------------|
| Design Priority  | Pedestrian  |  | In areas where there is or could be direct pedestrian and vehicular interaction, this requirement shall denote which user will be given the design priority.  | Section 2.3                       |
| Parkstrip Treatment  | Encouraged<br>(all types allowed)   |  | This requirement explains how to design the designated eight-foot parkstrip area. Parkstrip treatment areas may be larger or smaller than eight feet.   | Section 2.2                       |
| Clear Walkway  | 10 feet   |  | This requirement dictates the smallest amount of clear walkway space that shall exist at any given point along the street. Walkways should have a small meander.  |                                   |
| Minimum Setback from Pedestrian Space<br>(Building Space Size) | 6 feet  |  | This requirement shall dictate minimum setbacks. It creates a minimum extension to the pedestrian realm by forcing the building back.   | Subsection 2.1.3 &<br>Section 2.6 |
| Maximum Building Setback                                       | Primary Frontage  | Secondary Frontage   | Dictates the maximum distance any portion of the building frontage may be setback from the property line. Secondary Frontage setbacks will only be applicable on corner lots or lots with two or more frontages.  | Section 2.6                       |
|  | N/A   | N/A  |   |                                   |
| Paving Material  | Primary Material  | Secondary Material   | Dictates what type of pavement materials should be required in the pedestrian realm. Treatments for adjacent applications of both public and private portions of the pedestrian realm should be the same or similar. Saw cuts should create irregular shapes and patterns.  |                                   |
|  | Specialty paver &/or stamped, special, &/or colored concrete  | Specialty paver &/or stamped, special, &/or colored concrete |   |                                   |
| Pavement Interruption Frequency                                | 50 feet   |  | Dictates the minimum frequency at which a pavement interruption, LID measures, or a unique furnishings and/or amenity shall be incorporated into the public realm.  | Subsection 2.1.4                  |
| Number of Pedestrian Building Entrances                        | 2 per 200 feet  |  | Dictates the minimum number of street entrances to a building that shall be required.   |                                   |
| Block Breaks   | N/A   |  | The maximum length of any one block side allowed before another pedestrian break shall be required. Breaks should be created with streets and/or pedestrian mews. (May be substituted with the creation of a community gathering space with all applicable amenities, furnishings, and features).   | Subsection 9.1.6                  |
| Drive-Thru   | Prohibited  |  | Dictates whether or not a business with a drive-thru may be located on the thoroughfare.  | Section 2.8                       |
| On-Street Parking  | Temporary   |  | Dictates whether on-street parking is required, limited, temporary, or prohibited. This provision may require the dedication of additional right-of-way.  |                                   |
| Minimum Ground Floor Commercial                                | Encouraged  |  | Dictates the minimum amount of a building that shall be used for a retail, restaurant, entertainment, or other consumer based business or use.  | Section 2.7                       |
| Maximum Retail Space   | 8,000 sq/ft   |  | Dictates the maximum ground floor size of a single retail, restaurant, or other consumer based business or use. Commercial uses wanting additional space shall be required to use multiple stories.   | Section 2.7                       |
| Preferred Retail Uses  | Casual dining, fine dining, counter service dining, live entertainment venues, small scale consumer goods |  | When implemented in a vertical mixed use project, preferred retail uses can receive exemption from certain regulations at the discretion of the Community Development Director.<br><br>1. Relief from maximum retail space requirements up to 12,000 sq/ft.<br>2. Reduction of 70% frontage rule (section 2.6) to 50% minimum build to setback. |                                   |

*This chart does not contain all requirements. It is intended to be a quick reference for most requirements related to the streetscape and public realm design. The associated references must be read to understand all requirements and intents. A complete review of the entire document is encouraged to understand all requirements. To the extent there is any conflict between this chart and any Section(s) of the Design Standards referenced in this chart, the Section(s) shall govern.*



Figure 302 - Type 1 design example: street raised to match the sidewalk



Figure 303 - Type 1 design example: outdoor seating



Figure 304 - Type 1 design example: ground floor commercial



Figure 305 - Type 1 design example: street lighting



Figure 306 - Type 1 design example: pavement interruptions



Figure 307 - Type 1 design example: festivals and pedestrian interaction



Figure 308 - Type 1 design example: residential mew



Figure 309 - Type 1 design example: temporary landscaping in the building space



Figure 310 - Type 1 design example: public art

## STREETSCAPE DESIGN-TYPE 2

See in master plan = residential, RDE, district streets

| STREETSCAPE ELEMENT   | REGULATION THAT SHALL BE IMPLEMENTED  |  | EXPLANATION   | REFERENCE                      |
|---|---|--|---|--------------------------------|
| Design Priority   | Pedestrian  |  | In areas where there is or could be direct pedestrian and vehicular interaction, this requirement shall denote which user will be given the design priority.  | Section 2.3                    |
| Parkstrip Treatment   | Formal  |  | This requirement explains how to design the designated eight-foot parkstrip area. Parkstrip treatment areas may be larger or smaller than eight feet.   | Section 2.2                    |
| Clear Walkway   | 8 feet  |  | This requirement dictates the smallest amount of clear walkway space that shall exist at any given point along the street. Walkways should have a small meander.  |                                |
| Minimum Setback from Pedestrian Space (Building Space Size) | 10 feet   |  | This requirement shall dictate minimum setbacks. It creates a minimum extension to the pedestrian realm by forcing the building back.   | Subsection 2.1.3 & Section 2.6 |
| Maximum Building Setback                                    | Primary Frontage  | Secondary Frontage   | Dictates the maximum distance any portion of the building frontage may be setback from the property line. Secondary Frontage setbacks will only be applicable on corner lots or lots with two or more frontages.  | Section 2.6                    |
|   | 15 feet   | 20 feet  |   |                                |
| Paving Material   | Primary Material  | Secondary Material   | Dictates what type of pavement materials should be required in the pedestrian realm. Treatments for adjacent applications of both public and private portions of the pedestrian realm should be the same or similar. Saw cuts should create irregular shapes and patterns.  |                                |
|   | Saw-cut concrete  | Specialty paver &/or stamped, special, &/or colored concrete |   |                                |
| Pavement Interruption Frequency                             | 50 feet   |  | Dictates the minimum frequency at which a pavement interruption, LID measures, or a unique furnishings and/or amenity shall be incorporated into the public realm.  | Subsection 2.1.4               |
| Number of Pedestrian Building Entrances                     | 4 per 200 feet  |  | Dictates the minimum number of street entrances to a building that shall be required.   |                                |
| Block Breaks  | 400 feet  |  | The maximum length of any one block side allowed before another pedestrian break shall be required. Breaks should be created with streets and/or pedestrian mews. (May be substituted with the creation of a community gathering space with all applicable amenities, furnishings, and features).   | Subsection 9.1.6               |
| Drive-Thru  | Prohibited  |  | Dictates whether or not a business with a drive-thru may be located on the thoroughfare.  | Section 2.8                    |
| On-Street Parking   | Required  |  | Dictates whether on-street parking is required, limited, temporary, or prohibited. This provision may require the dedication of additional right-of-way.  |                                |
| Minimum Ground Floor Commercial                             | 30% and commercial or flex commercial on all corners  |  | Dictates the minimum amount of a building that shall be used for a retail, restaurant, entertainment, or other consumer based business or use.  | Section 2.7                    |
| Maximum Retail Space  | 8,000 sq/ft   |  | Dictates the maximum ground floor size of a single retail, restaurant, or other consumer based business or use. Commercial uses wanting additional space shall be required to use multiple stories.   | Section 2.7                    |
| Preferred Retail Uses                                       | Casual dining, fine dining, counter service dining, live entertainment venues, small scale consumer goods |  | When implemented in a vertical mixed use project, preferred retail uses can receive exemption from certain regulations at the discretion of the Community Development Director.<br>1. Relief from maximum retail space requirements up to 12,000 sq/ft.<br>2. Reduction of 70% frontage rule (section 2.6) to 50% minimum build to setback. |                                |

*This chart does not contain all requirements. It is intended to be a quick reference for most requirements related to the streetscape and public realm design. The associated references must be read to understand all requirements and intents. A complete review of the entire document is encouraged to understand all requirements. To the extent there is any conflict between this chart and any Section(s) of the Design Standards referenced in this chart, the Section(s) shall govern.*



Figure 311 - Type 2 design example: on-street parking



Figure 312 - Type 2 design example: prominent building frontages



Figure 313 - Type 2 design example: formal parkstrip treatment



Figure 315 - Type 2 design example: ground floor commercial



Figure 316 - Type 2 design example: pavement interruptions



Figure 314 - Type 2 design example: bicycle amenities

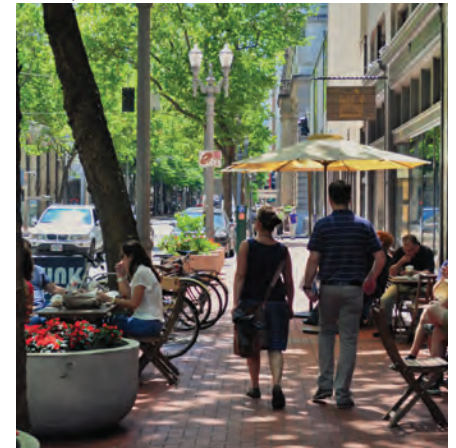

Figure 317 - Type 2 design example: encroachments should leave a clear walkway



Figure 318 - Type 2 design example: transit-oriented development



Figure 319 - Type 2 design example: outdoor seating



Figure 320 - Type 2 design example: ground floor fenestration



Figure 321 - Type 2 design example: awnings in the building zone

## STREETSCAPE DESIGN-TYPE 3

See in master plan = Collector and Distributor Street

| STREETSCAPE ELEMENT   | REGULATION THAT SHALL BE IMPLEMENTED  |   | EXPLANATION   | REFERENCE                      |
|---|---|---|---|--------------------------------|
| Design Priority   | Shared  |   | In areas where there is or could be direct pedestrian and vehicular interaction, this requirement shall denote which user will be given the design priority.  | Section 2.3                    |
| Parkstrip Treatment   | Informal  |   | This requirement explains how to design the designated eight-foot parkstrip area. Parkstrip treatment areas may be larger or smaller than eight feet.   | Section 2.2                    |
| Clear Walkway   | 8 feet  |   | This requirement dictates the smallest amount of clear walkway space that shall exist at any given point along the street. Walkways should have a small meander.  |                                |
| Minimum Setback from Pedestrian Space (Building Space Size) | 8 feet  |   | This requirement shall dictate minimum setbacks. It creates a minimum extension to the pedestrian realm by forcing the building back.   | Subsection 2.1.3 & Section 2.6 |
| Maximum Building Setback                                    | Primary Frontage  | Secondary Frontage                      | Dictates the maximum distance any portion of the building frontage may be setback from the property line. Secondary Frontage setbacks will only be applicable on corner lots or lots with two or more frontages.  | Section 2.6                    |
|   | 16 feet   | 25 feet                                 |   |                                |
| Paving Material   | Primary Material  | Secondary Material                      | Dictates what type of pavement materials should be required in the pedestrian realm. Treatments for adjacent applications of both public and private portions of the pedestrian realm should be the same or similar. Saw cuts should create irregular shapes and patterns.  |                                |
|   | Saw-cut concrete  | Stamped, special, &/or colored concrete |   |                                |
| Pavement Interruption Frequency                             | 75 feet   |   | Dictates the minimum frequency at which a pavement interruption, LID measures, or a unique furnishings and/or amenity shall be incorporated into the public realm.  | Subsection 2.1.4               |
| Number of Pedestrian Building Entrances                     | 3 per 200 feet  |   | Dictates the minimum number of street entrances to a building that shall be required.   |                                |
| Block Breaks  | 400 feet  |   | The maximum length of any one block side allowed before another pedestrian break shall be required. Breaks should be created with streets and/or pedestrian mews.   | Subsection 9.1.6               |
| Drive-Thru  | Limited - Only allowed where a project also fronts a type 4 street  |   | Dictates whether or not a business with a drive-thru may be located on the thoroughfare.  | Section 2.8                    |
| On-Street Parking   | Required  |   | Dictates whether on-street parking is required, limited, temporary, or prohibited. This provision may require the dedication of additional right-of-way.  |                                |
| Minimum Ground Floor Commercial                             | 15% and commercial or flex commercial on 1/2 of all corners   |   | Dictates the minimum amount of a building that shall be used for a retail, restaurant, entertainment, or other consumer based business or use.  | Section 2.7                    |
| Maximum Retail Space  | 10,000 sq/ft  |   | Dictates the maximum ground floor size of a single retail, restaurant, or other consumer based business or use. Commercial uses wanting additional space shall be required to use multiple stories.   | Section 2.7                    |
| Preferred Retail Uses                                       | Casual dining, fine dining, counter service dining, live entertainment venues, small scale consumer goods |   | When implemented in a vertical mixed use project, preferred retail uses can receive exemption from certain regulations at the discretion of the Community Development Director.<br>1. Relief from maximum retail space requirements up to 12,000 sq/ft.<br>2. Reduction of 70% frontage rule (section 2.6) to 50% minimum build to setback. |                                |

*This chart does not contain all requirements. It is intended to be a quick reference for most requirements related to the streetscape and public realm design. The associated references must be read to understand all requirements and intents. A complete review of the entire document is encouraged to understand all requirements. To the extent there is any conflict between this chart and any Section(s) of the Design Standards referenced in this chart, the Section(s) shall govern.*



Figure 322 - Type 3 design example: transit oriented design



Figure 323 - Type 3 design example: on-street parking



Figure 324 - Type 3 design example: ground floor retail and dining



Figure 325 - Type 3 design example: clear walkways



Figure 326 - Type 3 design example: primary frontage for a corner building



Figure 327 - Type 3 design example: safe pedestrian travel spaces

## STREETScape DESIGN-TYPE 4

See in master plan = Arterial and Boulevard Street

| STREETScape ELEMENT  | REGULATION THAT SHALL BE IMPLEMENTED                 |   | EXPLANATION  | REFERENCE                         |
|--|--|---|--|-----------------------------------|
| Design Priority  | Vehicle  |   | In areas where there is or could be direct pedestrian and vehicular interaction, this requirement shall denote which user will be given the design priority.   | Section 2.3                       |
| Parkstrip Treatment  | Combination  |   | This requirement explains how to design the designated eight-foot parkstrip area. Parkstrip treatment areas may be larger or smaller than eight feet.  | Section 2.2                       |
| Clear Walkway  | 10 feet  |   | This requirement dictates the smallest amount of clear walkway space that shall exist at any given point along the street. Walkways should have a small meander.   |                                   |
| Minimum Setback from Pedestrian Space<br>(Building Space Size) | 8 feet   |   | This requirement shall dictate minimum setbacks. It creates a minimum extension to the pedestrian realm by forcing the building back.  | Subsection 2.1.3 &<br>Section 2.6 |
| Maximum Building Setback                                       | Primary Frontage                                     | Secondary Frontage                      | Dictates the maximum distance any portion of the building frontage may be setback from the property line. Secondary Frontage setbacks will only be applicable on corner lots or lots with two or more frontages.   | Section 2.6                       |
|  | 20 feet  | 30 feet                                 |  |                                   |
| Paving Material  | Primary Material                                     | Secondary Material                      | Dictates what type of pavement materials should be required in the pedestrian realm. Treatments for adjacent applications of both public and private portions of the pedestrian realm should be the same or similar. Saw cuts should create irregular shapes and patterns. |                                   |
|  | Saw-cut concrete                                     | Stamped, special, &/or colored concrete |  |                                   |
| Pavement Interruption Frequency                                | 100 feet   |   | Dictates the minimum frequency at which a pavement interruption, LID measures, or a unique furnishings and/or amenity shall be incorporated into the public realm.   | Subsection 2.1.4                  |
| Number of Pedestrian Building Entrances                        | 2 per 200 feet                                       |   | Dictates the minimum number of street entrances to a building that shall be required.  |                                   |
| Block Breaks   | 500 feet   |   | The maximum length of any one block side allowed before another pedestrian break shall be required. Breaks should be created with streets and/or pedestrian mews.  | Subsection 9.1.6                  |
| Drive-Thru   | Limited  |   | Dictates whether or not a business with a drive-thru may be located on the thoroughfare.   | Section 2.8                       |
| On-Street Parking  | Limited  |   | Dictates whether on-street parking is required, limited, temporary, or prohibited. This provision may require the dedication of additional right-of-way.   |                                   |
| Minimum Ground Floor Commercial                                | 10% and commercial or flex commercial on all corners |   | Dictates the minimum amount of a building that shall be used for a retail, restaurant, entertainment, or other consumer based business or use.   | Section 2.7                       |
| Maximum Retail Space   | 20,000 sq/ft   |   | Dictates the maximum ground floor size of a single retail, restaurant, or other consumer based business or use. Commercial uses wanting additional space shall be required to use multiple stories.  | Section 2.7                       |

*This chart does not contain all requirements. It is intended to be a quick reference for most requirements related to the streetscape and public realm design. The associated references must be read to understand all requirements and intents. A complete review of the entire document is encouraged to understand all requirements. To the extent there is any conflict between this chart and any Section(s) of the Design Standards referenced in this chart, the Section(s) shall govern.*

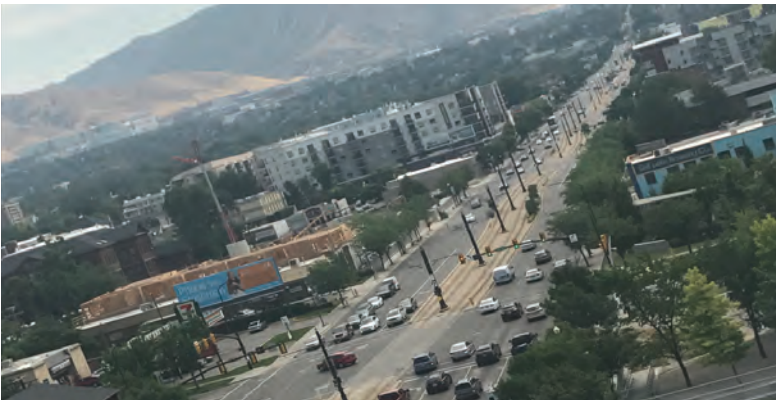

Figure 328 - Type 4 design example: convenient route for vehicular traffic



Figure 329 - Type 4 design example: vehicular oriented design



Figure 330 - Type 4 design example: high-quality pedestrian and vehicular design elements



Figure 331 - Type 4 design example: creative use of concrete in pedestrian space



Figure 333 - Type 4 design example: secondary building frontages



Figure 332 - Type 4 design example: car, train, and bikes lanes included



Figure 334 - Type 4 design example: easily visible crosswalks



## Chapter 4

# Building Massing

---

Where Mountain Meets Urban  
Base, Middle, and Top Treatments  
Specialty Uses  
Building Heights

This chapter will provide regulations to create buildings that promote pedestrian activity, safety, and community interaction through appropriate massing and arrangement. Massing and arrangement will help create the character of the street that is consistent with The Cairns Master Plan. All buildings should be designed with a variety of vertical and horizontal planes that provide physical breaks in a buildings' facade. This relief treatment will reduce the mass of buildings and provide an appropriate scale to each street. The massing of buildings has a significant influence on the overall character of The Cairns, and greatly affects the experience one will have when visiting. Evaluating how the building mass is broken up should be the first step in designing a new building.

## 4.1 Where Mountain Meets Urban Architecture

The following natural Wasatch Mountain Range elements should be used within buildings and architecture in The Cairns to connect mountain and urban.

**Architectural Canyons** – large, straight, continuous breaks in the facade that typically extend through multiple levels of the building.

**Architectural Crevices** – smaller breaks in a building used to break up planes and help create a rhythm in design. Can be horizontal, vertical, or angular.

**Architectural Cliffs** – large, uninterrupted drop of a building wall from a high part of the building. Usually done in conjunction with a series of ledges.

**Architectural Ledges** – one or more small drops in a buildings' mass. Best when done in a series of multiple ledges and with a cliff element.

**Architectural Hanging Valleys** – large and small uncovered decks usually used to help distinguish one level from the next. These spaces provide opportunities for outdoor areas and are used to reduce the mass of a building.

**Architectural Peaks** – the top of a building that is narrower than the base and middle. The peak is typically articulated with a different material or application of the material used in the middle. Peaks are best articulated with a series of ledges.



Figure 401- Lone Peak example of mountain features



Figure 402 - Office example of a modern take on Where Mountain Meets Urban architecture



Figure 403 - Residential example of a modern take on Where Mountain Meets Urban architecture

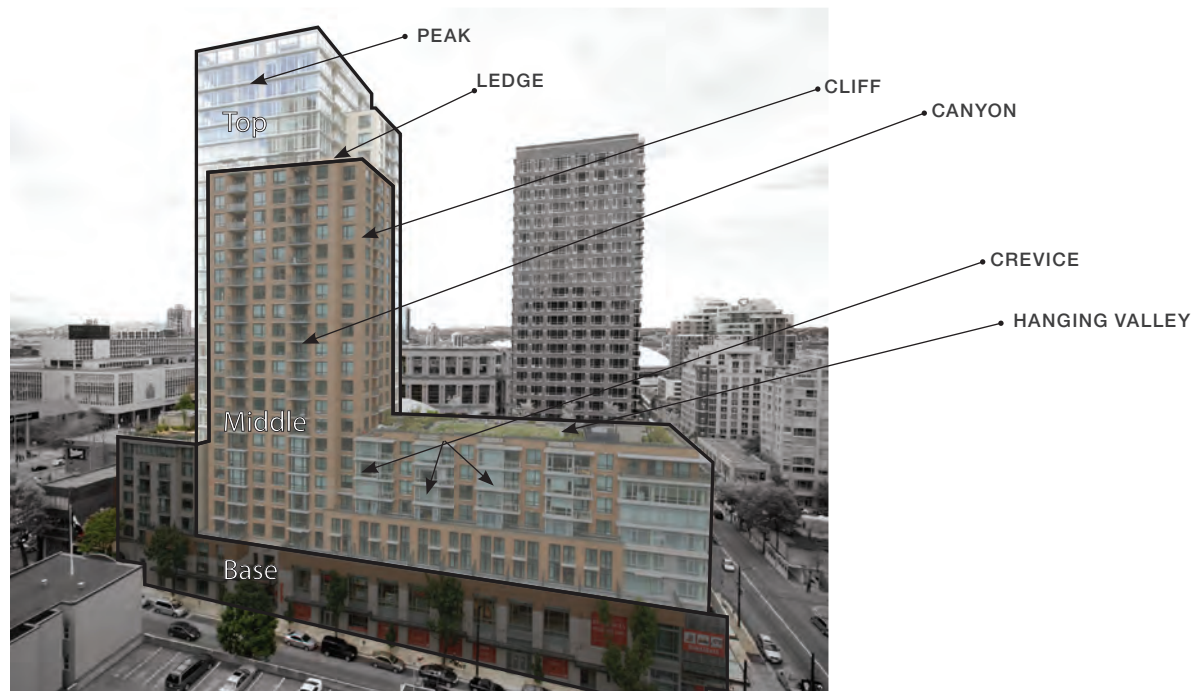

Figure 404 - graphic example showing how to implement mountain elements into buildings

## 4.2 Base, Middle, and Top Treatments

Along with the mountain elements, designing buildings with a defined base, middle, and top creates a connection to the Where Mountain Meets Urban theme. For a more in-depth interpretation of base, middle, and top treatments see The Cairns Master Plan pages 54-55.

**Building Base:** the base of the building should be well defined, with a clear break from the middle. It should include large windows with a unique treatment that help distinguish it from the middle and top of the building. The base should contribute to the quality of the public realm, having active frontages (windows with transparent glass providing views to the interior), porches, awnings, lighting, and high-quality materials, thus grounding the building to the site. In limited portions, the base and top treatments may intersect. (See figures 405 and 406)

**Building Middle:** the middle of the building should define the building, with multiple and varied planes that give the appearance of canyons, crevices, cliffs, and ledges. Step-backs between the middle and bottom or top provide opportunities for elevated ledges or hanging valleys. The middle should include elements that break up the building into multiple small elements and planes instead of one or two large elements. The middle should complement the architectural features of the base and the top by including windows and materials (see figure 406) that are visually cohesive with the base and the top, and that maintains the overall scale of the street.

**Building Top:** the top of a building should be tapered from the base and middle of the building – particularly for buildings ten stories or more. It should be a different material to further distinguish it from the other levels of the building. The top and middle of the building can and should have several elements that encroach one another. The majority of the top of a building should not be more than a couple stories. For smaller buildings (four stories or less), the top should consist of the roof and cornice treatment. This section should integrate the base and the middle to provide a visually coherent building.



Figure 405 - graphic highlighting a buildings base, middle, and top.



Figure 406 - Example of a building with a strong base, middle, and top



Figure 407 - Example of a building with a prominent top section

### 4.2.1 PRINCIPLES OF SUCCESS

- a. Create and preserve a human scale in architecture and articulation.
- b. Use Where Mountain Meets Urban and natural mountain elements to break up the mass of buildings.
- c. Reduce the mass of buildings by stepping them back as they increase in height.
- d. Create varied roof lines and levels with a series of step-backs, punched openings and protrusions in building architecture.

### 4.2.2 CHECKLIST OF REQUIREMENTS

- Each building facade shall have at least one horizontal break. Horizontal breaks shall be offset at least 3 feet from the building face. (See figure 408) This requirement may be excused if the building design meets this document's definition for iconic architecture
- All buildings shall have a distinguishable base, middle, and top as defined in this document.

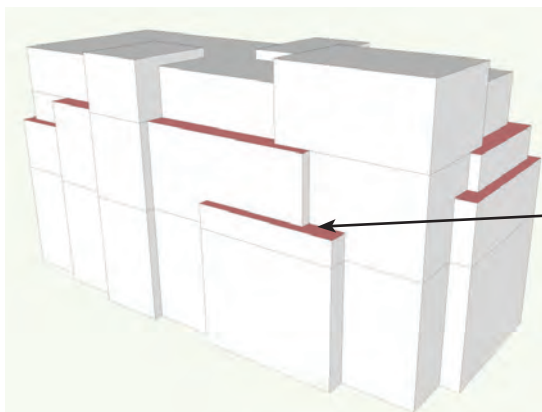

Figure 408 - Graphic illustrating examples of horizontal breaks

## 4.3 Specialty Uses

Entertainment, civic, and institutional uses present a unique opportunity to get iconic architectural buildings in Sandy City. All specialty uses shall go to the Planning Commission for review and approval. These uses may not be held to the same massing or building height standards as other uses. Specialty use buildings shall receive additional review and approvals, and will be given more flexibility in their design. For architectural requirements, please see section 5.1.4 of this document.

## 4.4 Building Heights

Residential, office, and hospitality use building heights in The Cairns shall be regulated by their location shown in figure 409. This map reflects areas that have been master planned. It will be updated as Study Areas are master planned and appropriate building heights are determined.

Although some areas allow single-story buildings, it is strongly encouraged that all buildings be at least two stories, or 20 feet in height in a single-story building. Development on properties associated with the Shops at South Town (shown in a hatch) may be allowed to go up to ten stories.

The preservation of mountain views is critical to maintaining the relationship between The Cairns and the Wasatch Mountains. The preservation of these views should be a consideration for each project in The Cairns.

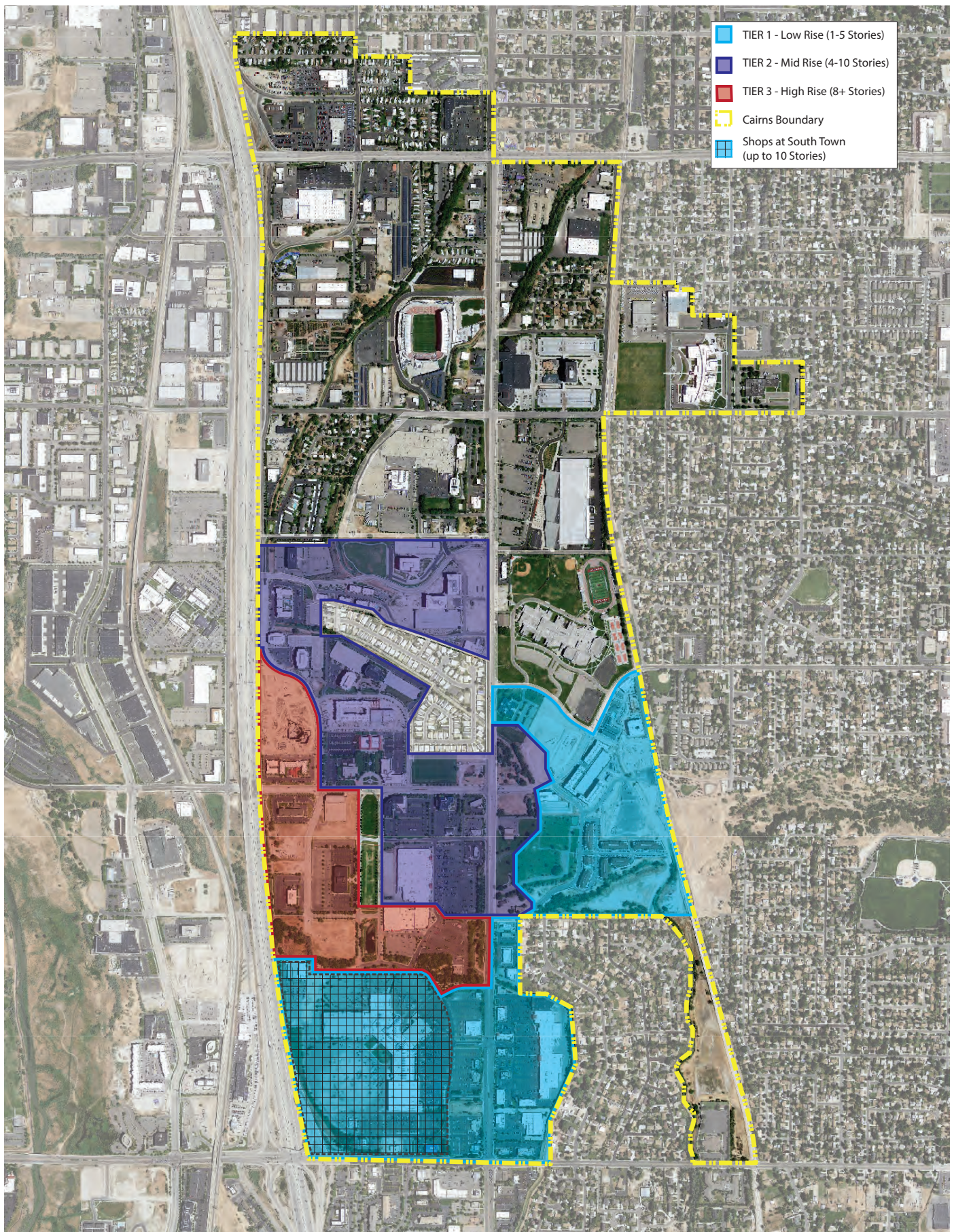

Figure 409 - Map showing building massing areas in The Cairns



## Chapter 5

# Building Architecture

---

Architecture  
Site Grade  
Roof Treatments  
Lighting

These architectural standards will establish a coherent theme for The Cairns which will provide this part of Sandy City with a meaningful and unique character. These controls will regulate how the building will be viewed from the public realm, while encouraging contemporary, urban designs that incorporate mountain themes.

THE  
CAIRNS

## 5.1 Architecture

Buildings in The Cairns are one of the most visible elements and should be designed with the Where Mountain Meets Urban theme in mind. Architecture in The Cairns should be used to help create a sense of identity, theme, and unity in the district.

### 5.1.1 PRINCIPLES OF SUCCESS:

- a. Relate the building and architecture to the natural site by stepping buildings and avoiding mass leveling of the site.
- b. Activate the public realm by enhancing the ground floor of buildings with material and massing articulations, lighting, furniture, windows, and signs.
- c. Screen or hide mechanical equipment, utility boxes, loading areas, and any other building element that may detract from the aesthetics of the structure.
- d. Use materials to accent and highlight the base, middle, and top of a building as well as any unique features of the building.
- e. Avoid blank, unarticulated walls and treatments.

### 5.1.2 COMMERCIAL AND HOSPITALITY USES

The commercial and hospitality uses in The Cairns should be designed to be easily accessible and inviting to pedestrians. Like most uses in The Cairns, commercial and hospitality building should create a human scale and a strong street presence to promote a walkable district.

#### MATERIAL REQUIREMENTS

- Full brick veneer, quarried stone, architectural metals, glass or pre-cast architectural concrete, or other high-quality material as recommended by The Cairns Architectural Review Committee (CARC), shall be used on at least 80% of building bases and 50% of building middles for all building facades visible from public streets
- Uninterrupted horizontal expanses of 50 feet in length of any opaque material, including opaque glass, shall be prohibited on building frontages visible from public streets
- Fully transparent, clear glass shall be required on the bottom two stories or 20 feet of any building for visibility at least three feet into the building
- Mirrored or highly reflective glass is prohibited. Opaque glass is prohibited from occupiable spaces

#### ENTRIES:

- Entries are encouraged at all block corners
- All retail or restaurant entries to a building shall include a material change or different articulation of the same material in and around the entry

Each entry to a building shall be articulated with at least one of the following:

- a. A horizontal shift in the facade of the building (at least two feet in or out) where the door is located
- b. A distinguishable architectural change which clearly defines the entry
- c. A canopy, overhang, or arch above the entrance
- d. Peaked roof or raised parapet structure over the door

FENESTRATION:

## Building Base:

- 70% minimum fenestration shall be required for bottom story along building frontages facing the street
- 50% minimum fenestration shall be required for 2nd story along building frontages facing the street

## Building Middle and Top:

- Middle and Top sections shall have between 50% and 80% glass window treatments for all facades



Figure 501 - Corner entrances on commercial uses

ARTICULATIONS:

- Buildings shall include a clearly defined base, middle, and top
- At block corners, buildings shall include enhanced articulation that minimally includes a building protrusion or recessed treatment

## Building Base:

- (Streetscape Design-Types 1, 2, 3) Horizontal building articulations for street facing walls shall be required at least every 50 feet to break up facades and create a human-scale
- (Streetscape Design-Type 4) Horizontal building articulations shall be required at least every 75 feet to break up facades
- Vertical articulations shall minimally extend to the full height of the ground floor

## Middle and Top:

- Vertical and horizontal divisions shall be required so that a variety of physical and material breaks exist in the facade
- Building facades shall include a sequence of articulations to provide architectural relief and shadowing



Figure 502 - Articulations for architectural relief



Figure 503 - Protruding display windows for fenestration



Figure 504 - High-quality materials on a building frontage



Figure 505 - Recessed corner treatment and a mix of architectural material

### 5.1.3 RESIDENTIAL USES

As with other uses, residential units in The Cairns should reflect the Where Mountain Meets Urban theme by incorporating high-quality materials and base, middle, and top treatments. These buildings should promote a walkable atmosphere while still preserving the privacy of residents by including fenestration and street entrances.

#### MATERIAL REQUIREMENTS:

- Full brick veneer, quarried stone, architectural metals, glass or pre-cast architectural concrete, or other high-quality material as recommended by The Cairns Architectural Review Committee (CARC), shall be used on at least 80% of building bases and 50% of building middles for all building facades visible from public streets
- Uninterrupted horizontal expanses over 25 feet in length of any opaque material shall be prohibited on all primary and secondary frontages

#### FENESTRATION REQUIREMENTS:

a. Multi-Family (see definitions) Building Base:

- Ground floor units should include at least 40% window treatments along all building frontages

b. Multi-Family Building Middle and Top:

- Middle and top stories shall have between 40% and 80% glass window treatments for all facades

c. Attached Single-Family (see definitions):

- Windows shall be required on all building frontages

#### ENTRY REQUIREMENTS:

- Ground floor units along street frontages shall include a primary entrance from the street
- Ground floor unit entrances should have a vertical separation from the adjacent sidewalk

#### ARTICULATION REQUIREMENTS:

- Buildings shall include a clearly defined base, middle, and top
- Balconies a minimum of four feet deep shall be required on at least 40% of all multi-family units
- Horizontal building articulations for building frontages shall be required at least every 25 feet to break up facades and create a human-scale
- Building protrusions or recessed treatment extending above the base of the building shall be required at block corners



Figure 506 - Residential entrance located above the sidewalk grade



Figure 507 - Single-family home with a front porch



Figure 509 - High-quality materials on residential buildings



Figure 508 - Create vibrant residential community spaces for multi-family homes



Figure 510 - Stairs off the sidewalk as primary entrances into residential uses



Figure 511- Attached single-family with windows on the primary frontage



Figure 512 - Residential fenestration and balconies



Figure 513 - Mixed use project with multi-family housing on top



Figure 514 - Multi-family housing with street entrances and balconies to "activate" the street

#### 5.1.4 INSTITUTIONAL, CIVIC, AND ENTERTAINMENT USES

Institutional, civic, and entertainment uses in The Cairns have the least strict requirements in order to create opportunities for iconic and unique architecture. These buildings should still meet the Where Mountain Meets Urban feel and promote street activity through their architecture.

##### MATERIAL REQUIREMENTS

- Full brick veneer, quarried stone, architectural metals, glass or pre-cast architectural concrete, or other high-quality material as recommended by The Cairns Architectural Review Committee (CARC), shall be used on at least 80% of building bases and 50% of building middles for all building facades visible from public streets
- Uninterrupted horizontal expanses over 25 feet in length of any opaque material shall be prohibited on all primary and secondary frontages

##### FENESTRATION:

- No less than 50% of the ground floor on-street facing walls should include a non-reflective, transparent glass treatment such that there is visibility at least three feet into the building

##### ENTRIES:

- Entries are encouraged at all block corners
- Each entry to a building shall be articulated with at least one of the following:
  - a. A horizontal shift in the facade of the building (at least two feet in or out) where the door is located
  - b. A distinguishable architectural change which clearly defines the entry
  - c. A canopy, overhang, or arch above the entrance
  - d. Peaked roof or raised parapet structure over the door

##### ARTICULATIONS:

- Buildings shall include a clearly defined base, middle, and top
- Building protrusions or recessed treatments extending above the base of the building shall be required at block corners

##### Building Base:

- (Streetscape Design-Types 1, 2, 3) Horizontal building articulations for building frontages shall be required at least every 25 feet to break up facades and create a human-scale
- Horizontal articulations shall minimally extend to the full height of the ground floor

##### Middle and Top:

- Vertical and horizontal articulation shall be required to create a variety of physical and material breaks in the facade
- Building facades shall include a sequence of articulations to provide architectural relief and shadowing



Figure 515 - Hale Centre Theatre with high-quality materials and design



Figure 518 - Stairs as an architectural design element



Figure 516 - Ground floor fenestration

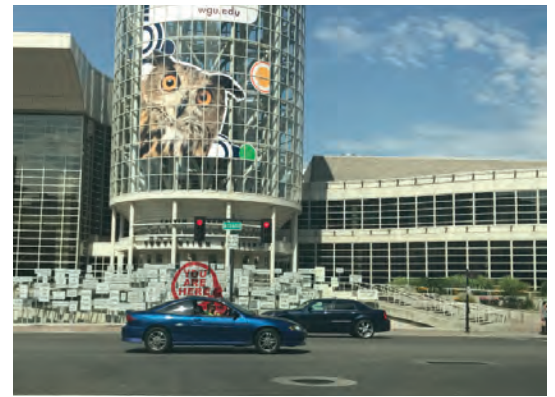

Figure 517 - Convention Center in Salt Lake City as an example of fenestration and unique articulations



Figure 519 - Rio Tinto Stadium, a popular entertainment center in Sandy City that draws visitors from the whole state



Figure 520 - Ground floor fenestration in these uses creates a "buzz" on the streetscape, making it seem busy and inviting

## 5.2 Site grade

### 5.2.1 CHECKLIST OF REQUIREMENTS

- Buildings should step with the natural grade of a site
- The foundation of a commercial building shall not extend above four feet from the grade of the adjacent sidewalk
- The foundation of a residential building shall not extend above six feet from the grade of the adjacent sidewalk
- Retaining walls shall not exceed five feet tall measured from the footing - Walls that are stepped shall have a ten-foot separation between retaining walls



Figure 521 - Utility equipment screening example



Figure 522 - Architectural roof capping

## 5.3 Roof Treatments

### 5.3.1 CHECKLIST OF REQUIREMENTS

- All roof top mechanical or utility equipment shall be screened (see figure 521- 523)
- Roof treatments shall be designed to architecturally cap the building (see figure 523)



Figure 523 - Utility equipment screening example



Figure 524 - Bollard lighting



Figure 525 - Directional lighting

## 5.4 Lighting

### 5.4.1 CHECKLIST OF REQUIREMENTS

- Public and private street lights and parking lot lights shall be configured in a manner that minimizes the amount of light pollution or light trespass onto adjacent properties (see figure 526)
- Public street lights within The Cairns District shall be installed as per Sandy City
- With the exception of landscape and architectural lighting, private outdoor spaces shall be lit with lighting that is shielded so it can only project downward (see figure 526)

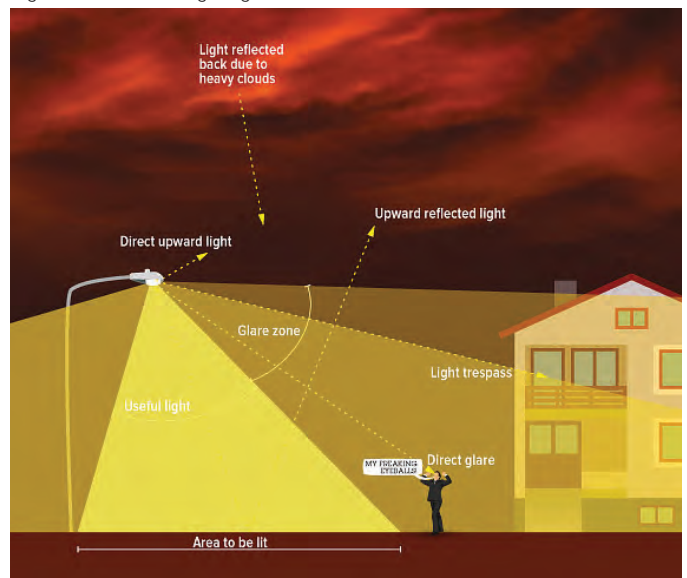

Figure 526 - Graphic showing why directional lighting is preferred

## Chapter 6

# Parking Arrangement

---

Surface Parking  
Structured Parking  
Parking Entrances

Parking and the way it is arranged is critical to the success of The Cairns. There must be adequate parking evenly distributed throughout The Cairns. Too much parking or parking arranged in the wrong manner can have a negative impact on the public realm and ultimately the aesthetic value of The Cairns. Proper parking arrangement will improve the public realm and enhance safety, encourage walkability, reduce surface parking, encourage on-site stormwater management, and properly integrate parking into the urban fabric.

## 6.1 Surface Parking

Surface parking is a traditional application of parking with a series of striped parking stalls on an improved (usually asphalt) surface. This type of parking is strongly discouraged and subject to Sandy City's parking ordinances. Surface parking lots are not permitted as a primary use. To use the adjacent chart, follow the guidelines for the streetscape design-type upon which your project's primary frontage falls.

### PRINCIPLES OF SUCCESS

- Preserve street frontages as much as possible for buildings and active pedestrian spaces by locating parking in places that it can be screened from the public realm.
- Provide required parking in parking structures whenever possible.
- Reduce the heat-island effect by covering parking surfaces with landscape materials.
- Provide clear and visible signage for parking locations and to designate to whom the parking is available.
- Use LID (Low Impact Development) or other creative solutions for dealing with stormwater from parking surfaces.
- Provide ample lighting and other security measures for the safety of parking facilities.
- Provide attractive and accessible pedestrian paths throughout surface parking lots to promote walkability.
- Provide electric vehicle charging stations whenever possible.

#### 6.1.1 SURFACE PARKING CHECKLIST OF REQUIREMENTS

- Surface parking shall comply with chart 601
- Where surface parking lots are allowed between a building and the street (Public Realm), at least 50% of the street frontage shall be fronted with buildings

- Where decorative screening is required, it shall minimally include a four-foot decorative wall and/or hedge
- Landscape island tree spacing may be adjusted up or down based on the type of tree
- Landscape island trees shall be a fruitless variety of tree

| SURFACE PARKING REQUIREMENTS   |                          |        |        |        |
|--|--------------------------|--------|--------|--------|
| Parking Lot Requirements for Primary Frontages   | Streetscape Design Types |        |        |        |
|  | Type 1                   | Type 2 | Type 3 | Type 4 |
| Maximum consumption of overall site  | 50%                      | 10%    | 15%    | 50%    |
| Allowed in the public realm  | L                        | N      | L      | L      |
| Maximum % of parking allowed along any public frontage (not including on-street parking) | 50%                      | 0%     | 20%    | 50%    |
| Minimum surface area to be landscaped  | 15%                      | 25%    | 20%    | 15%    |
| Evenly distributed landscaping within the parking lot                                    | •                        | •      | •      | •      |
| Minimum width of landscape islands   | 6 ft.                    | 6 ft.  | 6 ft.  | 8 ft.  |
| Master plan required for parking lots with 50+ surface stalls                            | •                        | •      | •      | •      |
| Minimum setback from public or private right-of-way                                      | 15 ft.                   | N      | 15 ft. | 15 ft. |
| Decorative screening required (for parking lots visible from public realm)               | •                        | N      | •      | •      |
| Minimum tree spacing for landscape islands   | 35 ft.                   | 35 ft. | 35 ft. | 35 ft. |

Chart 601 - Surface parking standards according to a project's primary frontage

• = required

L = limited (discouraged)

N = not permitted

////////////////////  
**6.1.2 SURFACE PARKING FOR PHASED DEVELOPMENT SITES**

Surface parking areas that are part of a phased development shall adhere to the applicable standards of each Streetscape Design Type (see chart 601). Phased surface parking areas may front streets beyond the percentages allowed in the Design-Types except Streetscape Design-Type 2 when approved by the Community Development Director. Phased parking



Figure 601 - Small parking lot landscaped with native grasses



Figure 602 - Large landscape island in a parking lot



Figure 603 - Landscaping in surface parking lots



Figure 604 - Parking in the vehicular ROW



Figure 605 - Safe pedestrian crossing in a parking lot



Figure 606 - Cairns branding in a parking lot

## 6.2 Structured Parking

This type of parking facility is an engineered structure designed to accommodate a series of ramps and parking stalls. This type of parking facility reduces the effective footprint needed to satisfy parking requirements and preserves space for additional occupied building uses. This type of parking is strongly encouraged.

### PRINCIPLES OF SUCCESS

- a. Preserve street frontages as much as possible for buildings and active pedestrian spaces by locating parking in places that can be screened from the public realm.
- b. Provide required parking in parking structures whenever possible.
- c. Reduce the heat-island effect by covering parking surfaces structurally or with landscape materials.
- d. Provide clear and visible signage for parking locations and to designate to whom the parking is available.
- e. Use LID (low impact development) or other creative solutions for dealing with stormwater from parking surfaces.
- f. Provide ample lighting and other security measures to enhance safety.
- g. Implement CPTED (Crime Prevention Through Environmental Design) design techniques whenever possible.
- h. Provide electric vehicle charging stations whenever possible.

### 6.2.1 STRUCTURED PARKING CHECKLIST OF REQUIREMENTS

- Structured parking shall comply with chart 602
- Where shown on chart 602, parking structures should only be allowed along secondary frontages
- Four-sided screening shall shade vehicles and visually screen structures from adjacent uses and streets
- Leasable ground floor commercial or flex-space in parking structures is encouraged

- Architectural screening shall minimally follow two of the articulation requirements for its associated use as outlined in Chapter 5
- Architectural screening shall include full brick veneer, quarried stone, architectural metals, glass or pre-cast architectural concrete, or other high-quality material as recommended by The Cairns Architectural Review Committee (CARC)

| STRUCTURED PARKING REQUIREMENTS                                 |  |                         |        |        |        |
|---|--|-------------------------|--------|--------|--------|
| Requirements  |  | Streetscape Design-Type |        |        |        |
|   |  | Type 1                  | Type 2 | Type 3 | Type 4 |
| Allowed locations   | Behind building                            | •                       | •      | •      | •      |
|   | Side/adjacent to building                  | •                       | L      | •      | •      |
|   | In front of building                       | L                       | N      | N      | L      |
|   | Block corners                              | N                       | L      | N      | N      |
|   | Adjacent to community space                | L                       | L      | N      | N      |
| Structure screening required                                    |  | •                       | •      | •      | •      |
| Structure height limited to primary building height             |  | •                       | •      | •      | N      |
| Structures adjacent to public realm                             | % of ground floor commercial               | 35%                     | N      | 70%    | 35%    |
|   | Architectural treatments to match building | •                       | N      | •      | •      |
| Min. setback for non-commercial treatment along public frontage |  | 6 ft.                   | N      | 10 ft. | 10 ft. |

Chart 602 - Structured parking standards according to a project's primary frontage

• = allowed

L = limited (discouraged)

N = not permitted

6.2.2 SUB-SURFACE PARKING STRUCTURES

Sub-Surface parking structures are the most desirable in The Cairns. Where a parking structure is partially above and below the site surface, portions above shall be subject to the provisions of Section 6.2.1 Structured Parking Requirements Chart. See Chapter 10 of this document for available incentives for designing sub-surface parking structures.



Figure 606 - Parking garage decorated to brand The Cairns



Figure 607 - Parking garage screened as an architectural element



Figure 608 - Parking garage left open with native landscaping

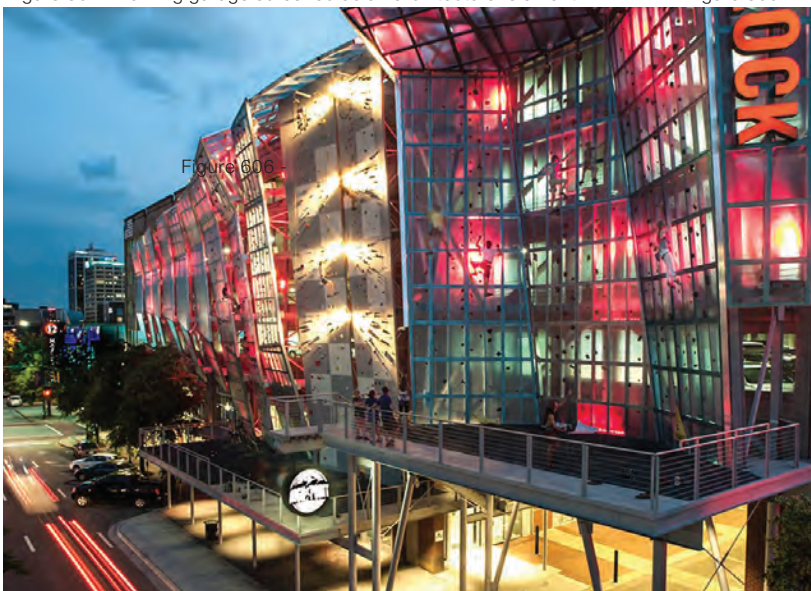

Figure 609 - Parking garage fronted with rock-climbing element



Figure 610 - Parking garage turned into public art

## 6.3 Parking Entrances

Any type of parking facility, surface, structured, or sub-surface structured, should be strategically designed to limit the number of entrances. Cross-access easements should be used between any adjacent commercial purpose parking lots. Easements may be required based on the anticipated amount of time the surface parking may be used. The following requirements shall be applied to all parking facility entrances.

### 6.3.1 PARKING ENTRANCE CHECKLIST OF REQUIREMENTS

- Parking ingress and egress for a double-lane entrance shall be a maximum of 24 feet wide
- Parking ingress and egress for single-lane entrances shall be a maximum of 14 feet wide
- Parking ingresses and egresses shall be at least 60 feet from block corners for single lane entrance
- Parking ingresses and egresses shall be at least 80 feet from block corners for double lane entrance
- The number of entrances should be limited to a single ingress and egress per street frontage, per parking facility



Figure 611 - Parking entrance blends with the streetscape



Figure 612 - Parking entrance screened by landscaping



Figure 613 - Parking entrance architecturally enhanced with brick and awning

## Chapter 7

# Furnishings and Landscaping

---

Furnishings  
Landscaping

Furnishings and landscape design are an important tool in realizing the Where Mountain Meets Urban theme of The Cairns. Because the landscaping and furnishings of a project will be at the ground level, interaction between these elements and people in the public realm will be high. For that reason, every opportunity to create a mountain experience with landscape materials and furnishings should be used. This chapter will guide landscape treatments and the use of furnishings on both public and private land to help encourage this interaction and implement mountain elements.

## 7.1 Furnishings

The following pages include a series of example images for public and private furnishings. Furnishings include benches and other seating elements, bollards, light poles, bike racks, tree grates, and fencing to name a few. These elements contribute to an active public realm and create a pedestrian scale. These examples and images are intended to inspire creativity and provide examples of how and where to apply these elements.

Some elements inside the public ROW will have a required specification that must be used, i.e. street lights, benches, etc. All elements inside the public realm but outside this ROW should be creatively designed and placed, consistent with the Where Mountain Meets Urban theme.

Creative applications of furnishings inside the public realm may be considered a development enhancement. (See Appendix D.)

### 7.1.1 CHECKLIST OF REQUIREMENTS:

#### TREE GRATES, MANHOLE COVERS AND SIDEWALK MEDALLIONS:

- Manhole covers (with the exception of sewer district manhole covers) shall be Cairns branded and have an additional identifying marker indicating storm water, water, etc.
- Tree grates shall provide at least 16 square feet of permeable surface
- Tree grates, manhole covers, and sidewalk medallions shall be crafted using high quality materials from the pre-approved list, or as per Sandy City Standard Specifications

#### TRASH RECEPTACLES:

- Privately maintained trash receptacles should be placed in the building space close to entrances but no less than one every 200 feet
- Recycling receptacles should be paired with at least 1/2 of all trash receptacles (also to be placed in the building zone and privately maintained)
- Trash receptacles shall be crafted using high-quality materials or come from the pre-approved list in Appendix B of this document

#### BIKE RACKS:

- Each project shall have one bike rack that can accommodate a minimum of 4 bicycles
- Bike racks should be on the primary frontage of a project in the building zone
- Bike racks shall be crafted using high-quality materials or come from the pre-approved list in Appendix B of this document

#### BENCHES

- Benches should be provided at a minimum of one for every 200 or 300 feet of linear frontage within the building space
- Benches should be placed near transit, public open spaces, and shopping and dining opportunities
- Benches shall be crafted using high-quality materials or come from the pre-approved list in Appendix B of this document

#### FENCING

- Fencing in the public realm shall not be more than 80% opaque
- Fencing shall be crafted using high-quality materials. Vinyl fencing is discouraged and chain-link fencing shall not be permitted
- Fencing in the public realm shall not be taller than 40 inches

#### BOLLARDS

- Bollards in the public realm shall not be taller than 40 inches
- Decorative and lighted bollards should be crafted using high-quality materials such as wood, stone, or prefabricated plastics

**7.1.2 TREE GRATES**

Geared mostly toward pedestrians, themed tree grates have the ability to unify an area and create a sense of consistency. Though most tree grates of high-quality design are accepted, a list of pre-approved tree grates can be found in appendix B of this document.



Figure 701 - Brick cut-out tree grate



Figure 702 - Urban Accessories - Chinook 2000

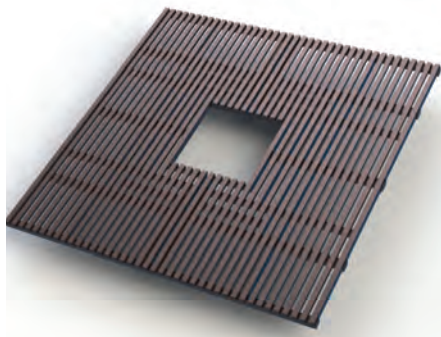

Figure 703 - Urban Accessories - Jamison



Figure 704 - Iron Age - Locust

**7.1.3 MANHOLE COVERS AND SIDEWALK MEDALLIONS**

Along with themed tree grates, manhole covers and sidewalk medallions have the ability to unify an area and promote a brand. Figures 705, 706, and 708 are templates for branding manhole covers and sidewalk medallions with The Cairns logo. They are designed to be simple, unique, and long lasting.



Figure 705 - Cairns branded sidewalk medallion

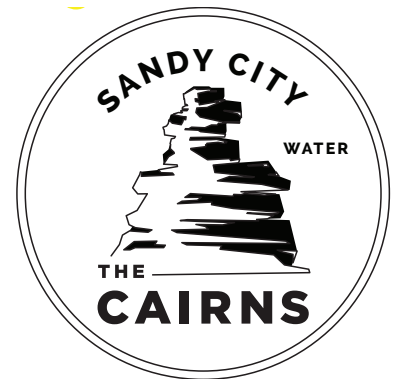

Figure 706 -Cairns branded water cover



Figure 707 - Local example of a branded manhole cover



Figure 708 - Cairns branded storm water cover

## 7.1.4 TRASH RECEPTACLE

Trash receptacles should be placed next to buildings, other street furnishings, inside landscape or otherwise in a location that is visible but does not interrupt pedestrian traffic. Recycling receptacles are strongly encouraged. These should be placed next to trash receptacles so the option to recycle is convenient. Creative applications of stone, alloy, prefabricated plastics, or natural wood are appropriate. Though most receptacles of high-quality design are accepted, a list of pre-approved receptacles can be found in Appendix B of this document.



Figure 709 - Anova - Airi Receptacle



Figure 710 - Forms + Surfaces Apex receptacle



Figure 711 - Wood material trash receptacle



Figure 712 - Modern shape trash receptacle

## 7.1.5 BIKE RACK

Bike racks provide opportunity for unique and artistic furnishings in The Cairns. When placed in frequent and convenient locations, they also encourage the use of bicycles as a mode of transportation. Every project in The Cairns, whether commercial or residential shall include a place to secure and park bikes. Though most bike racks of high-quality design are accepted, a list of pre-approved bike racks can be found in Appendix B of this document. Public bike lockers are also highly encouraged.



Figure 713 - Forms + Surfaces Bike Garden



Figure 714 - Forms + Surfaces Trio Bike Rack



Figure 715 - Mountain materials on bike rack



Figure 716 - Unique shape bike rack

7.1.6 BENCHES

Benches should be used frequently throughout The Cairns. Places to sit are particularly important next to and inside community spaces, near transit stops, and near shopping and dining businesses. Though most benches of high-quality design are accepted, a list of pre-approved benches can be found in Appendix B of this document.



Figure 717 - Forms + Surfaces - Boardwalk Bench



Figure 718 - Anova - Airi Bench



Figure 719 - Landscape Forms - Milenio Bench



Figure 720 - Landscape Forms - Strata Beam Bench



Figure 721 - Bench built into planter

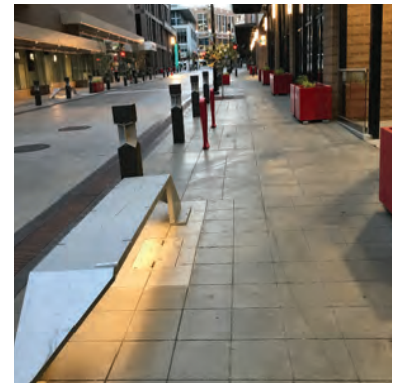

Figure 722 - Bench with lighting



Figure 723 - Planter bench



Figure 724 - High-quality materials in bench

7.1.7 FENCING

Fencing inside the public realm will generally be discouraged. Appropriate applications may include enclosed outdoor seating or around a landscape treatment that needs protection. Fencing inside the public realm should be unique and artistic.



Figure 725 - Unique fencing



Figure 726 - Fencing in outdoor dining areas



Figure 727 - Fencing mixed with landscaping



Figure 728 - Where Mountain Meets Urban type fencing



Figure 729 - High-quality fencing materials



Figure 730 - Fencing used as screening outside public realm

7.1.8 BOLLARD

Bollards may be lit along trails or other circumstances where the added light is needed. Creative applications of stone, alloy, prefabricated plastics, or natural wood are appropriate.



Figure 731 - Bollards to light pedestrian path



Figure 732 - Bollard placed in landscaping to provide lighting



Figure 733 - Use of high-quality materials



Figure 734 - Varying sizes for visual appeal

## 7.2 Landscaping

Landscaping in The Cairns is essential to creating the Where Mountain Meets Urban theme. Landscaping in the public realm softens the urban setting visually. Along with the following ideas, each project should design landscaping with the four mountain elements listed in Chapter 1 of this document (water, stone, meadow, and forest) in mind to keep The Cairns a beautiful and consistent combination of mountain and urban.

### PRINCIPLES FOR SUCCESS

- a. Planting plans should consist of native plant species that are drought tolerant, and/or have a successful track record in the local climate.
- b. Landscaping should provide a combination of hardscape and softscape elements that break up the landscape and give a more natural appearance.
- c. Landscaping should provide healthy, vibrant streets within all public spaces in order to improve the appearance of streets and create a buffer between pedestrian and vehicle travel lanes.
- d. Landscaped areas should use trees to shade large expanses of pavements and reduce the urban heat island effect.
- e. Landscaping should promote prudent use of water and energy resources and should be sustainable and functional.

- f. Landscaping should reflect and relate to mountain elements, in both design and materials.
- g. Landscaping should be used to soften building edges, screen mechanical and/or parking areas, and shade gathering spaces.
- h. Landscaping should ideally perform dual function of water quality treatment and detention of stormwater, snow storage, and deicing salt runoff.

### 7.2.1 LANDSCAPING CHECKLIST OF REQUIREMENTS

- Shrubs, bushes, and grasses shall cover no less than 40% of all softscape areas
- There shall be a minimum of one tree planted for every 400 square feet of landscaping
- Plant materials and landscape design shall be designed to reflect the mountain elements and themes outlined in Chapter 1 of this document
- Each site shall be designed with a variety of trees, shrubs, bushes, and grasses – no fewer than three species of tree and three species of shrubs, bushes, and grasses
- All landscaping shall meet LID requirements
- Up to 50% of the landscaping may be transferred to a green wall so long as the wall starts at the ground floor and is in view of the public right-of-way
- Up to 60% of the required landscaping may be transferred to a rooftop garden and still meet the intent of these requirements
- Plants shall come from the approved plant list in Appendix C of this document



Figure 735 - An example of mountain meets urban landscaping

## 7.2.2 RAISED PLANTERS

Raised planters provide a unique opportunity to establish seating spaces while creating varied elevation treatments for planting landscapes. Raised planters are very effective at activating spaces and are highly encouraged throughout the streetscape.



Figure 736 - Raised planters in outdoor seating



Figure 737 - Raised planters can double as seating



Figure 738 - Raised planters provide seating



Figure 739 - Modern touch to raised planters



Figure 740 - Raised planters encourage meandering



Figure 741 - Raised planter with grass

## 7.2.3 IN-GRADE PLANTER

In-grade planters have many different applications, but is particularly applicable when designing with low impact development (LID) standards. These planters are typically depressed below the grade of the sidewalk. Careful attention should be given to design these with defined edges so people don't fall or trip into them.



Figure 742 - In-grade planters look more natural



Figure 744 - In-grade planter in a parkstrip

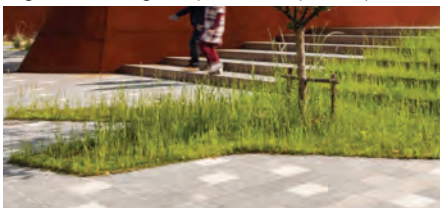

Figure 745 - In-grade planter extending onto stairs



Figure 743 - Border along in-grade planter for safety



Figure 746 - In-grade planter with decorative stones

### 7.2.4 FIRE PITS

Fire pits (natural gas) are encouraged and are a desirable amenity for the public realm when placed outside the public ROW. Fire pits should always be raised above the site grade so that the risk of falling in is limited. Fire pits should be constructed from a natural stone or brick masonry product and placed in the building space.



Figure 747 - Urban fire pit

### 7.2.5 NATURALISTIC PLAY STRUCTURE

Inside and out of community spaces, play structures that encourage naturalistic play are strongly encouraged. These types of amenities contribute to The Cairns and also provide a less traditional form of recreation.



Figure 748 - Natural play structure



Figure 749 - Rock climbing structure

### 7.2.6 STEPPING STONES

This element works really well in conjunction with a water feature, however this treatment is not required. Stepping stones are indicative of a trail or natural environment and are a great way to bring this element to an urban landscape.



Figure 750 - Urban stepping stones



Figure 751 - Mountain stepping stones



## Chapter 8

# Monuments & Wayfinding

---

Primary Gateway Monuments  
Secondary Gateway Monuments  
Vehicular, Pedestrian, Interpretive,  
and Trail Signage

Monuments and wayfinding are general terms intended to represent elements within The Cairns that will provide patrons of The Cairns with a sense of arrival and direction. Each new project in The Cairns will be reviewed to determine if and where wayfinding signage is needed, what type of wayfinding signage is appropriate and where the signage will be located.

# 8.1 Primary Gateway Monuments

Primary gateway monuments create a sense of grand entrance into The Cairns with their large size and elaborate use of material. The commanding structure invokes the Where Mountain Meets Urban feeling and sets the tone for the rest of the development. Primary gateway monuments may be considered as an enhancement for purposes of Chapter 10 of this document. Subject to budget appropriations, the City may, but is not obligated to, provide or participate in providing some elements of primary gateway monuments.

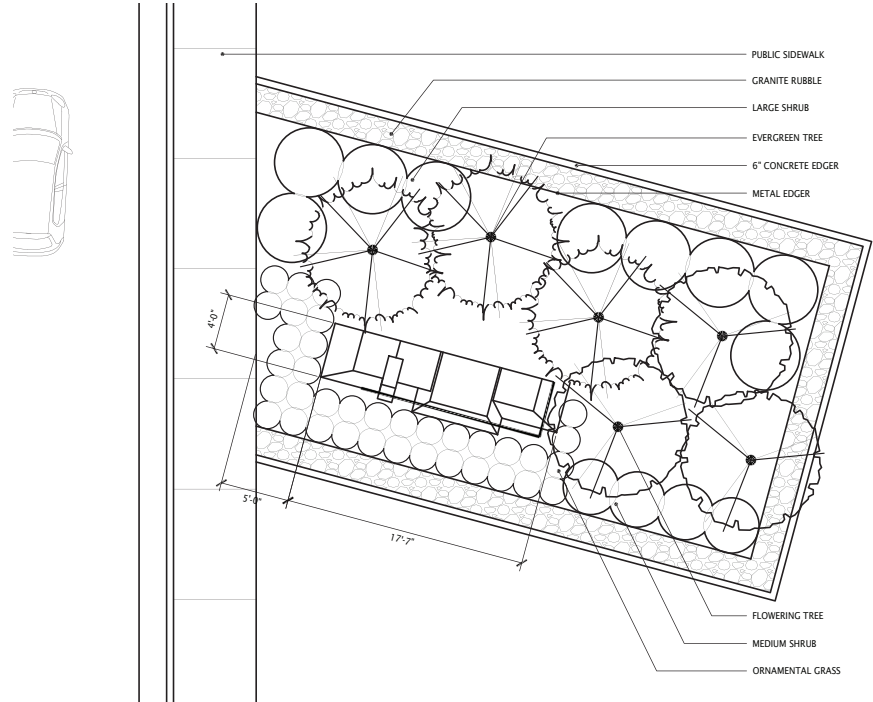

Figure 801 - Birds-eye view of a primary gateway monument

## 8.1.1 CHECKLIST OF REQUIREMENTS

- Primary gateway monuments should be at least 15 feet tall

Primary gateway monuments shall use granite veneer (figure 809), lighting (figure 812), and no less than 4 other elements from the following list:

- a. Evergreen trees (see figure 802 and Appendix C)
- b. Ornamental trees (see figure 803 and Appendix C)
- c. Large shrubs (see figure 804 and Appendix C)
- d. Medium height shrubs (see figure 805 and Appendix C)
- e. Ornamental grasses (see figure 806 and Appendix C)
- f. Granite rubble (see figure 807)
- g. Corten/dark bronze (see figure 810)
- h. Stainless steel (see figure 811)

- Primary gateway monuments shall be branded with The Cairns logo



Figure 802 - Evergreen trees are indicative of the mountains and create a great backdrop for many structural elements



Figure 803 - Ornamental trees bring a bit of the modern into our mountain landscape



Figure 804 - Large shrubs provide color and screening around the signage



Figure 805 - Medium height shrubs add base to any planting arrangement



Figure 806 - Ornamental grasses reinforce a natural mountain feel



Figure 807 - 4-8 inch angular granite rubble makes a strong visual base for The Cairns's large monuments

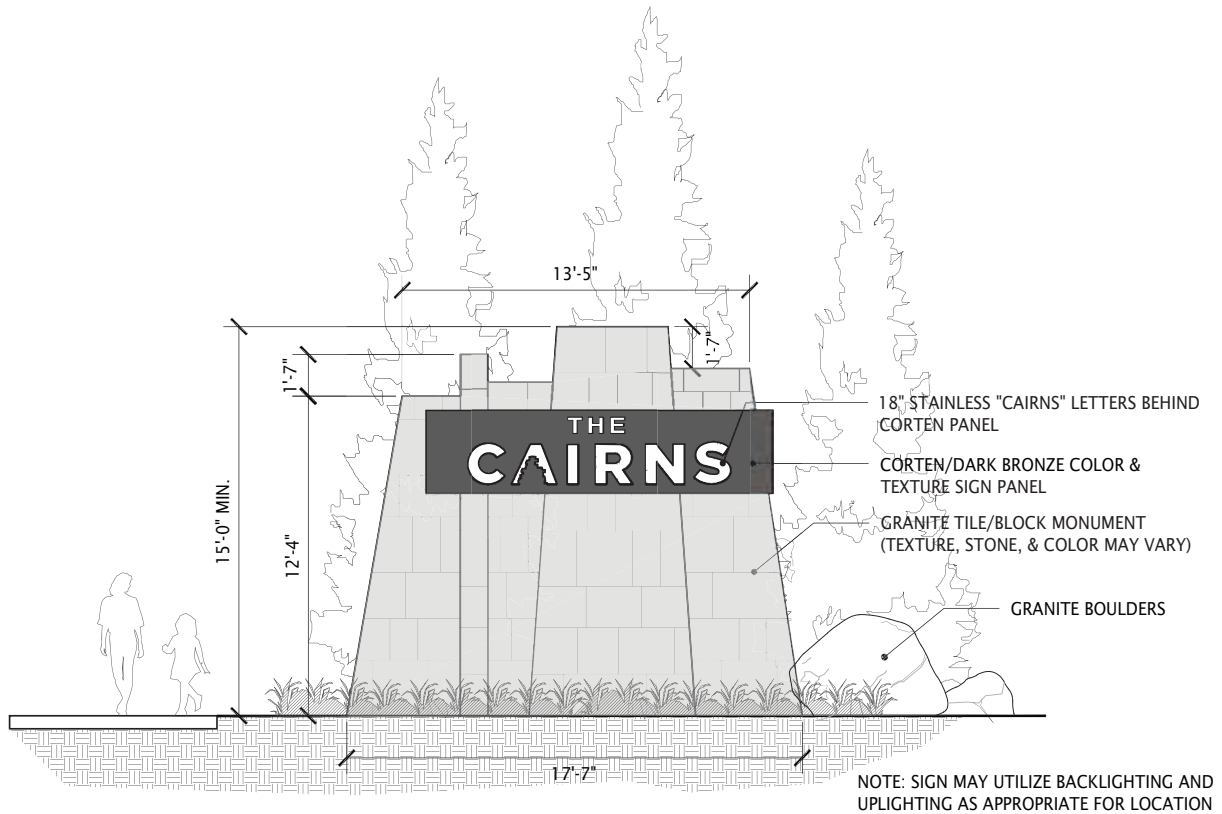

Figure 808 - Front view of a primary gateway monument



Figure 809 - Natural hewn granite veneer is a perfect homage to the natural stone in the area



Figure 810 -Corten/Dark bronze is an urban material that is durable and beautiful

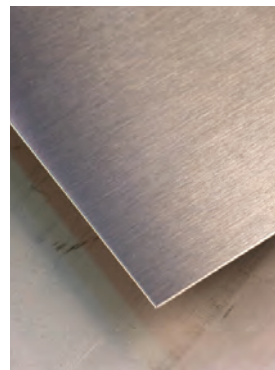

Figure 811 - Stainless steel is a modern, durable, and workable material



Figure 812 - Lighting, whether from behind or below adds visual interest and nighttime visibility

THE CAIRN

A cairn is a marker, usually a stack of stones, used to identify a trail or significant location. In The Cairns, cairns will be used as public art and in some cases may be viewed as landmarks. The use of these unique elements will provide a physical manifestation for the namesake of The Cairns – helping to reinforce The Cairns identity. The use of interpretive cairns elements in architecture, landscape and project branding is encouraged.

# 8.2 Secondary Gateway Monuments

Secondary gateway monuments are slightly smaller than primary. Their purpose is to reinforce The Cairns theme and create a sense of place throughout the whole district. Using similar materials and plantings will invoke a similar emotion to the entrance sign while keeping the development feeling fresh. Secondary gateway monuments may be considered as an enhancement for purposes of Chapter 10 of this document. Subject to budget appropriations, the City may, but is not obligated to, provide or participate in providing some elements of secondary gateway monuments.

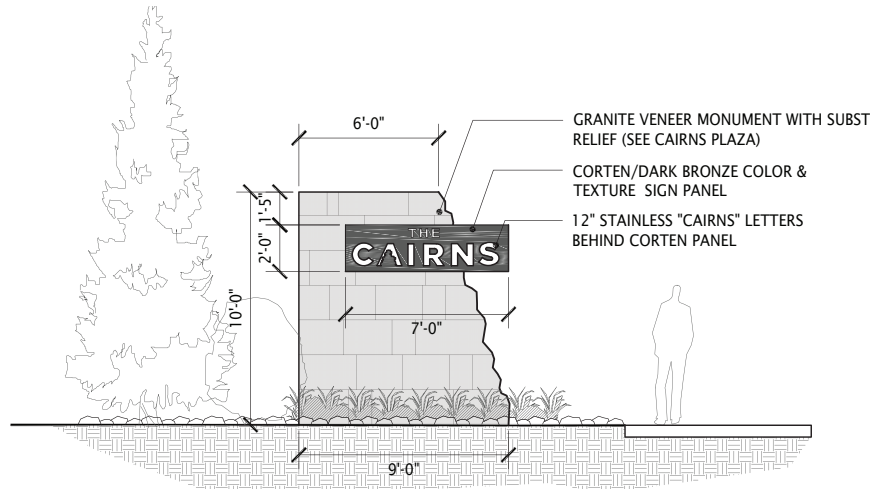

Figure 813 - Front view example of a secondary gateway monument

## 8.2.1 CHECKLIST OF REQUIREMENTS

- Secondary gateway monuments should be at least 10 feet tall

Secondary gateway monuments shall use granite veneer (figure 820), lighting (figure 821), and no less than 2 elements from the following list:

- a. Evergreen trees (see figure 814 and Appendix C)
- b. Medium height shrubs (see figure 815 and Appendix C)
- c. Ornamental grasses (see figure 816 and Appendix C)
- d. Granite rubble (see figure 819)
- e. Corten/dark bronze (see figure 822)

- Secondary gateway monuments shall be branded with The Cairns logo



Figure 814 - Evergreen trees are indicative of the mountains and create a great backdrop for many structural elements



Figure 815 - Medium height shrubs add base to any planting arrangement



Figure 816 - Ornamental grasses reinforce a natural mountain feel

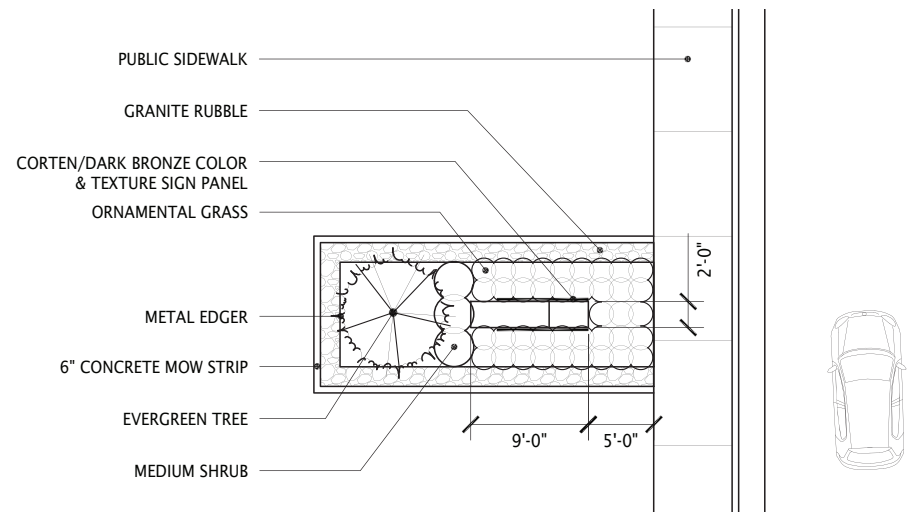

Figure 817 - Birds-eye view of a secondary gateway monument

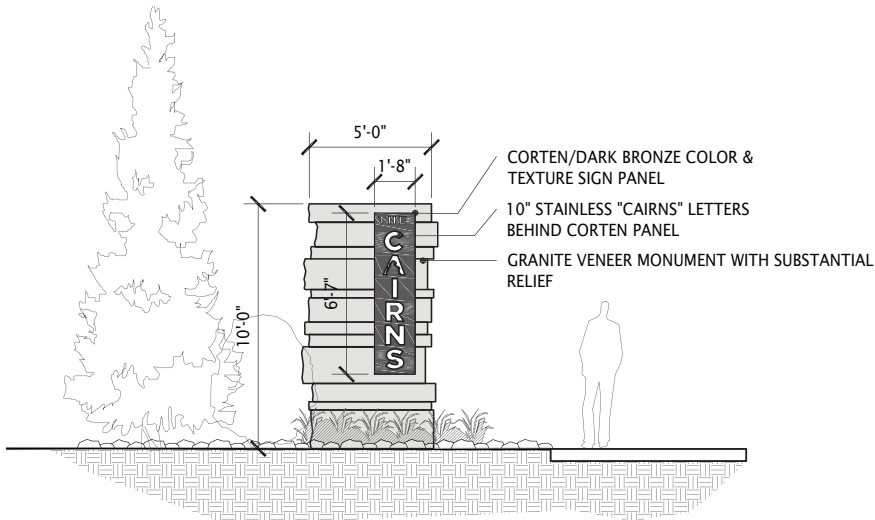

Figure 818 - Front view example of a secondary gateway monument



Figure 819 - 4-8 inch angular granite rubble makes a strong visual base for The Cairns large monuments



Figure 820 - Natural hewn granite veneer is a perfect homage to the natural stone in the area



Figure 821 - Lighting, whether from behind or below adds visual interest and nighttime visibility



Figure 822 -Corten/dark bronze is an urban material that is durable and beautiful

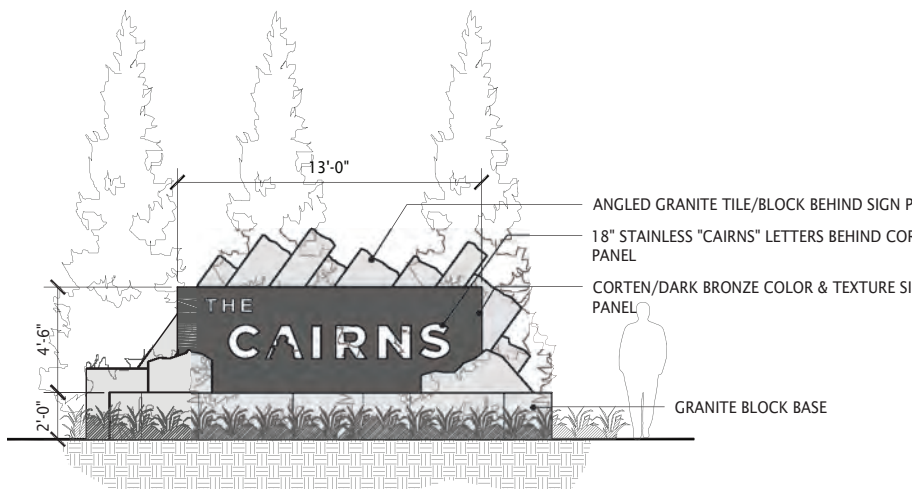

Figure 823 - Front view example of a secondary gateway monument

# 8.3 Vehicular, Pedestrian, Interpretive, and Trail Signage

Vehicular, pedestrian, interpretive, & trail signage is used to identify The Cairns and assist visitors in navigating through The Cairns. See pages 94-95 in The Cairns Master Plan for a map of desired locations for vehicular wayfinding. Graphic examples of interpretive signs can be found in Appendix E. Some wayfinding elements that are not internal or exclusive to the site may be considered as an enhancement for purposes of Chapter 10 of this document. Subject to budget appropriations, the City may, but is not obligated to, provide or participate in providing some elements of wayfinding in The Cairns.

## 8.3.1 CHECKLIST OF REQUIREMENTS

- ❑ Pedestrian wayfinding signage should be at least 8 feet tall
- ❑ Vehicular wayfinding signage should be at least 10 feet tall
- ❑ Print shall be easily visible on all wayfinding signage (this can be done in several ways, see images 826-828)
- ❑ All wayfinding signage shall be constructed with high-quality materials such as granite, bronze, and stainless steel
- ❑ All wayfinding signage shall be branded with The Cairns logo

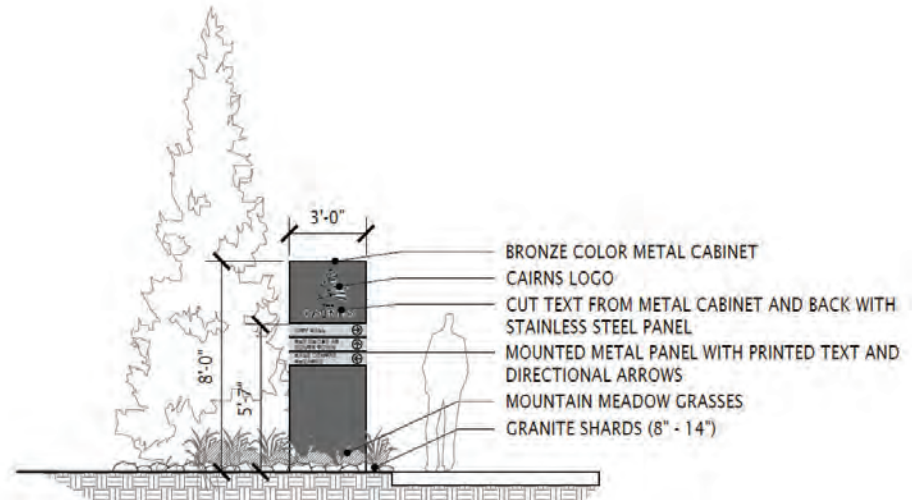

Figure 824 -Front view of pedestrian wayfinding signage

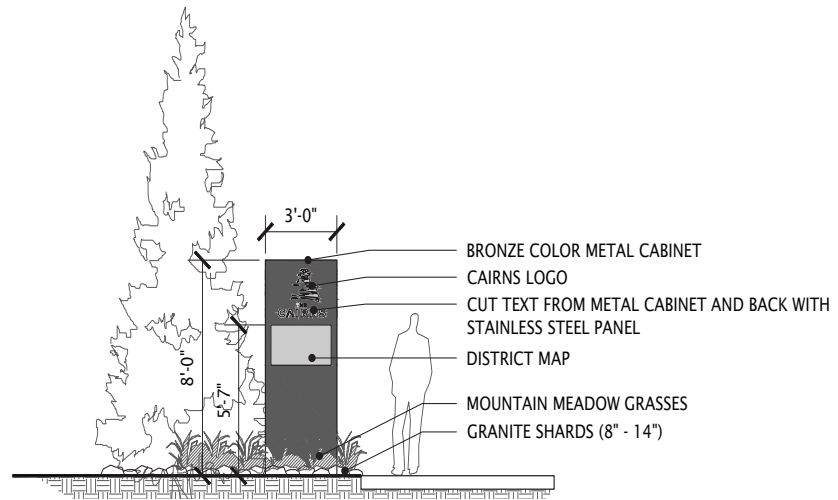

Figure 825 - Front view of a district map style pedestrian wayfinding signage



Figure 826 - Lighting, whether from behind or below adds visual interest and nighttime visibility



Figure 827 - The bronze and stainless materials work in tandem to make a beautiful readable, sign



Figure 828 - Printed letters on stainless steel makes for a clean look

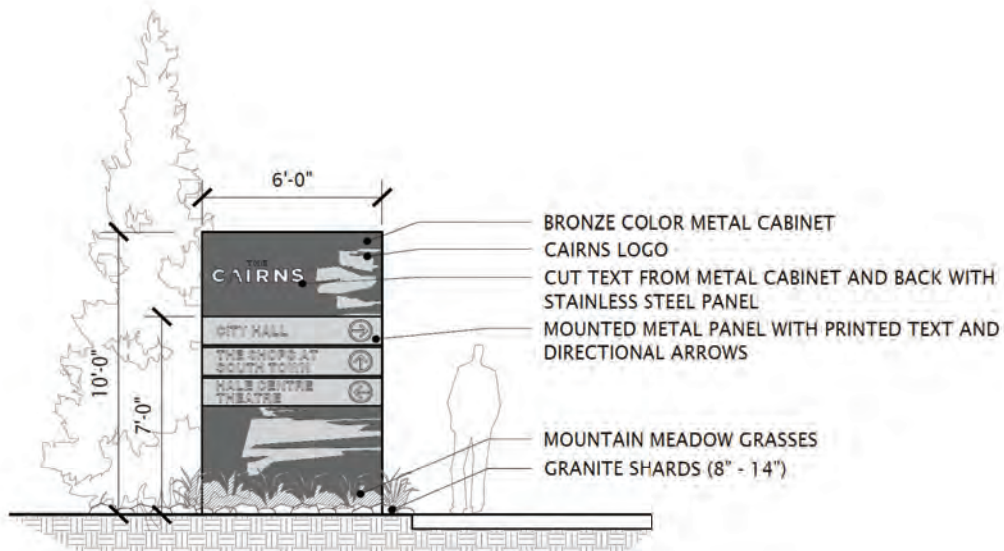

Figure 829 - Front view of a vehicular wayfinding signage

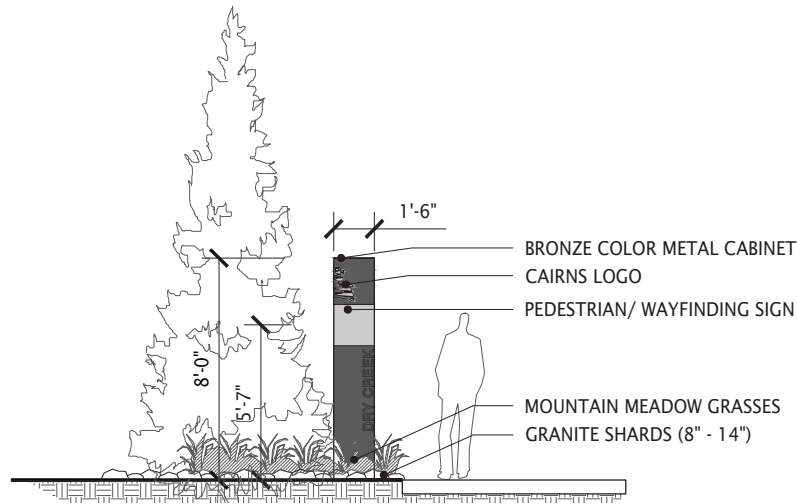

Figure 830 - Front view of trail signage for The Cairns



Figure 831 - Natural hewn granite veneer is a perfect homage to the natural stone in the area



Figure 832 -Corten/dark bronze is an urban material that is durable and beautiful

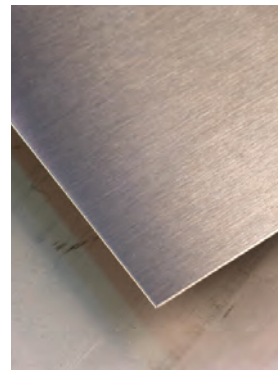

Figure 833 - Stainless steel is a modern, durable, and workable material



## Chapter 9

# Community Spaces

---

### Open Space:

Pocket Open Space

Square

Plaza

Neighborhood Open Space

Pedestrian Mews

The Cairns includes a variety of open spaces that will enhance the area and give people a place to play, recreate, attend events, and escape the hardscape environment of an urban setting. These public spaces shall be scattered throughout The Cairns and be available to everyone. There should be a variety of different types of open space available for every user of The Cairns, and available within close proximity to everything in the district.

## 9.1 Open Space

Having a variety of different community spaces scattered throughout The Cairns is vital to its success. In some circumstances, designing and building a community space for public use may be considered a development enhancement (see Chapter 10). In circumstances approved by the city, these spaces may be dedicated to Sandy City. Some open space elements that are not internal or exclusive to the site may be considered as an enhancement for purposes of Chapter 10 of this document. Subject to budget appropriations, the City may, but is not obligated to, provide or participate in providing some elements of open space in The Cairns. The following requirements apply for all new development or redevelopment:

- All residential units in The Cairns shall be within ¼ mile (1320 feet) walking distance to a publicly accessible open space from the front or primary entrance of a unit
- All uses in The Cairns shall be within ½ mile (2640 feet) walking distance from a publicly accessible open space of any type
- In the case where open space is proposed and installed by a developer, a development and maintenance plan for the open space shall be submitted to the City

### PRINCIPLES OF SUCCESS

- a. Provide open spaces where they are visible and accessible to the public.
- b. Design open spaces for a particular purpose that introduces new amenities and functions to small areas of The Cairns.
- c. Promote gathering spaces where people can meet and socialize.

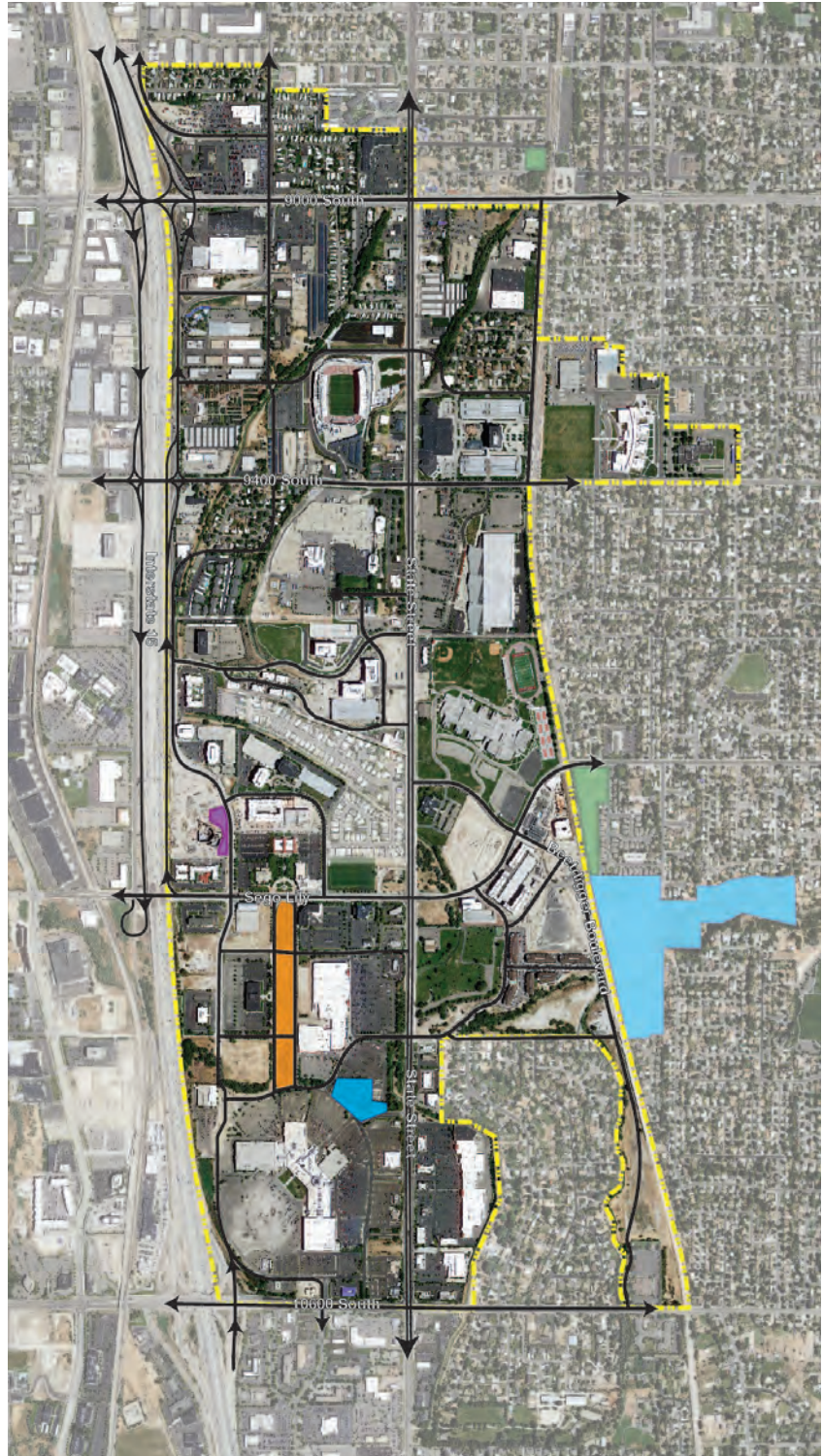

Figure 901 - Map of existing open spaces in The Cairns

| Open Spaces   |   |  |  |
|---|---|--|--|
| <span style="display: inline-block; width: 15px; height: 15px; background-color: orange; border: 1px solid black;"></span> Square                     | <span style="display: inline-block; width: 15px; height: 15px; background-color: purple; border: 1px solid black;"></span> Plaza            |  |  |
| <span style="display: inline-block; width: 15px; height: 15px; background-color: lightblue; border: 1px solid black;"></span> Neighborhood Open Space | <span style="display: inline-block; width: 15px; height: 15px; background-color: green; border: 1px solid black;"></span> Pocket Open Space |  |  |

**9.1.2 POCKET OPEN SPACE**

A pocket open space is a small open space designed and equipped for the rest and recreation of urban dwellers. Pocket open spaces should be interspersed within residential and commercial areas and designed for small gatherings of people (50-200).

These spaces should be built within gaps in-between or at the edges of built development, primarily in and around residential areas.

**CHECKLIST OF REQUIREMENTS**

- Pocket open spaces should be at least 6,000 square feet in size
- Pocket open spaces shall promote family activities with structured recreational opportunities



Figure 902 - Graphic illustration of a pocket open space



Figure 903 - Community garden in a pocket open space



Figure 904 - Trail in a pocket open space



Figure 905 - Hammocks as a structural play element



Figure 906 - Water feature as a structural play element

### 9.1.3 SQUARE

A square is an open space provided to soften the urban city center and provide a contrasting environment so as to achieve the feel of entering an oasis or calm in the center of the city. These spaces should be less frequent than pocket open spaces but located in strategic places that are close to higher densities of residential. Squares should be designed for unstructured recreation and civic purposes. They should be designed for multiple uses that accommodate large event gatherings (1,000 + People) and located at intersections of important thoroughfares, streets, and building axes.

#### CHECKLIST OF REQUIREMENTS

- Squares should be somewhat screened by landscaping to enhance the “oasis” feel
- Landscaping in square open spaces should consist mostly of lawns, trees, and shrubs
- Squares may include some paths and paved areas for benches, tables, or navigation of the square
- Squares should be a minimum one acre in size



Figure 907 - Graphic illustration of a square

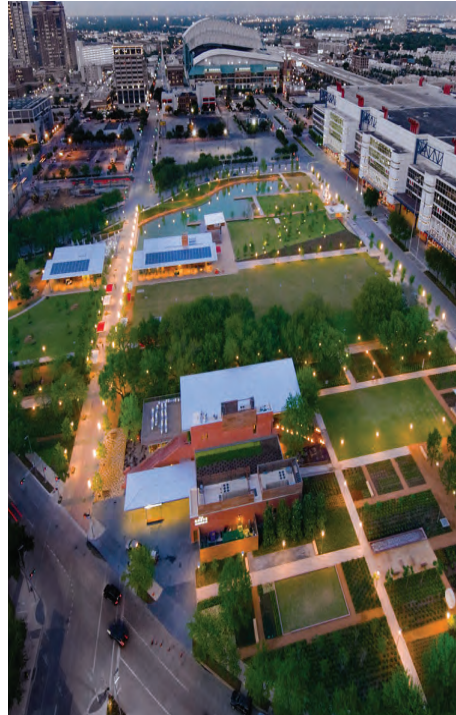

Figure 909 - Example of a well-lit square



Figure 908 - Squares draw pedestrian activity



Figure 910 - Example of a path in a square



Figure 911 - Squares can be used for large gatherings and festivals

**9.1.4 PLAZA**

A plaza is an open space provided for unstructured recreation and civic purposes. The landscaping in a plaza should consist of primarily hardscape with a formal application of trees and other softscape elements. Plazas should be designed for multiple uses that accommodate small to medium gatherings of people (50-1,000 people) and located at intersections of important thoroughfares and streets and/or spaces with large amounts of pedestrian traffic.

**CHECKLIST OF REQUIREMENTS**

- ❑ Plazas should be used in more urban, active locations as a gathering or meeting place in commercial or more intensive residential locations
- ❑ Plazas should be mainly hardscape
- ❑ Plazas shall have some point of emphasis or attraction (ie: fountains, sculptures, historic element, etc.)



Figure 912 - Graphic illustration of a plaza



Figure 913 - Waterfall in a plaza as a point of interest



Figure 914 - Raised planters and trees in a plaza



Figure 915 - Green elements can be incorporated into a plaza



Figure 916 - Splash pads and other interactive elements can create a point of interest in a plaza

### 9.1.5 NEIGHBORHOOD OPEN SPACE

A neighborhood open space is an open space designed for recreational and civic activities. They're intended to attract both local and regional visitors. The landscaping in neighborhood open spaces should be primarily softscape with a variety of paths and other hardscape gathering spaces. Trees and other landscape elements should be planted in a natural fashion. These open spaces should be designed for multiple uses that accommodate small, medium, or large gatherings of people (50-1,000+ people).

#### CHECKLIST OF REQUIREMENTS

- Neighborhood open spaces shall have unique features to draw pedestrians from the whole region
- Neighborhood open spaces shall accommodate a wide range of users and activities



Figure 917 - Graphic illustration of a neighborhood open space



Figure 918 - Festival at a neighborhood open space



Figure 919 - Neighborhood open space in an urban setting



Figure 920 - Neighborhood open space incorporating nature elements



Figure 921 - Neighborhood open space as a gathering area



### 9.1.6 BLOCK BREAKS

Block breaks (commonly known as pedestrian mews) are narrow pedestrian-only paths located between buildings, usually used to break up large blocks that would otherwise exceed maximum block lengths. These open spaces are also a type of streetscape and may provide limited vehicular access where it is the only viable access to commercial or residential entries. See Chapter 3 “Streetscape design-type 1” for more requirements.

PRINCIPLES FOR SUCCESS:

- a. Pedestrian mews and block breaks should follow crime prevention through environmental design guidelines (CPTED).
- b. These areas should be well lit and easily visible.
- c. Raised planters and seating should be used where possible in these spaces.
- d. Residential and commercial uses fronting these areas generate pedestrian traffic and make mews and block breaks inviting.



**CHECKLIST OF REQUIREMENTS**

- Pedestrian mews and block breaks should have a 20-foot minimum width
- Pedestrian mews and block breaks shall have at least two five-foot minimum clear pathways
- There should be a minimum of 20% planted softscape in pedestrian mews and block breaks
- Pedestrian mews and block breaks shall meet the standards for streetscape design-type 1 in Chapter 3 of this document



Figure 922 - Rendering of a block break with landscaping in the middle



Figure 924 - Block breaks provide an opportunity for vibrant retail spaces



Figure 923 - Block breaks should be well lit and inviting



Figure 925 - Landscaping and unique paving materials can make block breaks more inviting

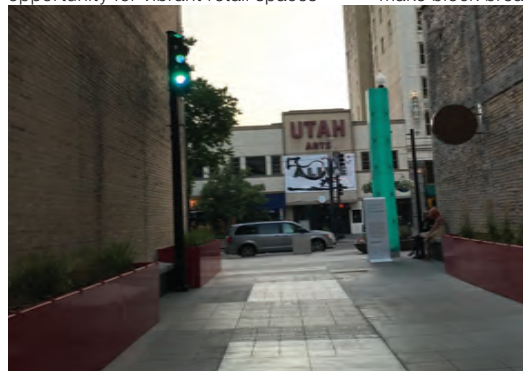

Figure 926 - Pedestrian wayfinding makes block breaks easy to find and navigate

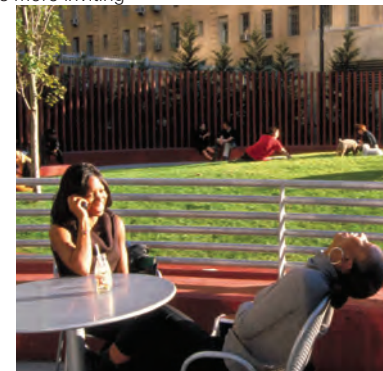

Figure 927 - Outdoor seating in block breaks can create a social setting



Figure 928 - Landscaping can create shelter from elements and a sense of human scale



Figure 929 - Block breaks can be larger than 20 feet in width in certain areas



## Chapter 10

# Development Enhancements

---

Enhancements Intent  
Development Enhancements

The provisions of this chapter are intended to provide exceptions to the standards of this document in circumstances where a better design solution may be presented. These enhancements may also offer relief to standards of this document where there are unique circumstances preventing the implementation of certain standards. The Community Development Director and Planning Commission shall make determinations according to this chapter.

## 10.1 Enhancements Intent

The following enhancements are available to developers looking for relief from the requirements of this document. The Planning Commission may grant exceptions to any of the standards contained within this document. The Planning Commission may also determine whether a unique site circumstance can be considered a hardship.

Exceptions to these standards may be granted by: (a) the Director pursuant to Appendix D, or (b) the Planning Commission pursuant to this Chapter.

### 10.1.1 NON-HARDSHIPS

The Planning Commission may grant an exception to any Cairns design standard if the Planning Commission finds that the design includes one or more enhancements set forth in the Cairns design standards, and the proposed design with such enhancements will meet all of the following:

- The intent of the applicable regulations; and
- The intent of the Master Plan; and
- The same or better quality design as determined by the Planning Commission

The Planning Commission shall not grant an exception solely for economic relief, regardless of the number or type of enhancements provided.

If the Planning Commission finds that all of the above requirements are not met, the Planning Commission may deny the requested relief, or the Planning Commission may require additional enhancements that will meet the requirements.

### 10.1.2 HARDSHIPS

The Planning Commission may make a finding of hardship, if the Planning Commission finds all of the following:

- The property has unique circumstances; and
- Enforcement of the standard would cause an unreasonable hardship for the applicant; and
- The hardship is not self-imposed; and
- The hardship is not solely economic; and
- The intent of the Master Plan is met

If the Planning Commission makes a finding of hardship, the Planning Commission may grant an exception to any Cairns design standard as follows:

- Without a condition requiring enhancements; or
- With a condition requiring only minimal enhancements that do not create undue hardship and either lessen the deviation from the applicable regulations, or produce the same or better quality design



Figure 1001 - Public amenities for an open space



Figure 1002 - Example of iconic architecture

## 10.2 Development Enhancements

The Planning Commission may require any number of elements from the following list of enhancements before granting relief from the standards of this document. Enhancements not listed here may also be considered as mitigation as approved by the Planning Commission. The extent to which any of these enhancements are implemented or the number of enhancements required should be proportionate to the exception(s) being requested.

- a. A donation of 0.05% of projects total construction costs to the city art fund
- b. Silver level LEED Certification or comparable sustainable building practice
- c. Iconic or Unique Architecture  
(When a buildings architectural costs exceed a 50% construction cost increase when compared to the average for the same building type in The Cairns. Measured on a per square foot basis.)
- d. Creation of a Community Gathering Space, complete with all applicable amenities, furnishings, and features
- e. Design and construction of a green roof (covering no less than 40% of roof surface)
- f. Creation of a public art piece or series of pieces for a community space or inside the public realm  
(Public art inside the public realm can be placed anywhere within The Cairns and still receive credit for the enhancement. Public art may include but is not limited to, art pieces, statues, water features, and large landscape enhancements that exceed base requirements.)
- g. Construction of a sub-grade (below grade) parking structure
- h. Design and construction of a Village Gateway Sign  
(The design of this sign shall be approved by The Cairns Branding Subcommittee and located at an approved location.)



Figure 1003 - Public open space



Figure 1004 - Landscaped green roof



Figure 1005 - Example of public art



## Chapter 11

# Utility & Loading Arrangement

Loading and Utility Areas  
Mechanical and Utility Equipment

---

This chapter will allow for the location of mechanical, utility, and loading facilities in a way that satisfies adequate accessibility while minimizing their visibility and impact – particularly from the public realm.

# 11.1 Loading and Utility Areas

## 11.1.1 LOADING AREAS

- Loading areas shall be screened from view of the public realm with a minimum six-foot decorative stone or masonry wall and vegetation
- Loading areas should not be closer than 25 feet to the public realm

## 11.1.2 TRASH AND WASTE DUMPSTERS

- Trash and waste dumpsters shall be placed on a concrete pad that is enclosed on three sides with a minimum six-foot tall masonry wall
- Trash and waste dumpsters shall be screened from view of the public realm
- Outdoor grease traps shall be located behind buildings



Figure 1101 - Loading area screened with a masonry wall



Figure 1102 - Dumpster enclosure for a commercial use



Figure 1103 - Dumpsters enclosed using high quality materials

# 11.2 Mechanical and Utility Equipment

## 11.2.1 MECHANICAL AND UTILITY BOXES

- ❑ Mechanical and utility boxes shall be screened from view in a decorative manner from the public realm
- ❑ Utility boxes shall not be located inside a dedicated ROW except when buried (exceptions may be granted by staff for traffic light boxes)
- ❑ Mechanical boxes shall be located on rooftops, inside a building, or behind a building where they are not visible from the public realm
- ❑ Commercial mechanical units that generate noise should not be allowed within 200 feet of any residential use unless noise can be dampened sufficient to limit noise area to a 50-foot radius from the mechanical unit

## 11.2.2 WALL MOUNTED EQUIPMENT

- ❑ Wall mounted equipment shall not be located on any primary or secondary building frontage
- ❑ Wall mounted equipment shall be screened from view of the public realm in a decorative manner

## 11.2.3 ROOF MOUNTED EQUIPMENT

- ❑ Roof mounted equipment shall be screened to eliminate the view of the equipment from any ground location within 350 feet
- ❑ Any roof mounted equipment five feet or taller shall be screened using walls of a matching height constructed to match the finish materials of the building



Figure 1104 - Wall mounted equipment screened with a masonry wall



Figure 1105 - Wall-mounted equipment screened by landscaping



Figure 1106 - Utility boxes screened by landscaping



Figure 1107 - Wall mounted equipment hidden from pedestrian realm



## Chapter 12

# Terms Definitions

---

Words or phrases not defined in this document shall be defined as contained in the Sandy City Land Development Code. If the word or phrase is not defined in either of these documents, the generally accepted definition of said word shall apply.

1. 70% Rule: this rule relates to the percentage of a proposed building frontage that must be built within 5 feet of the minimum (or maximum when applied to a secondary frontage) setback determined by the streetscape design-type.
2. Architectural Canyons: large straight and continuous breaks in the facade that typically extend through multiple levels of the building.
3. Architectural Cliffs: large, uninterrupted drop of a building wall from a high part of the building. Usually done in conjunction with a series of ledges.
4. Architectural Crevices: smaller breaks in a building used to break up planes and help create a rhythm in design. Can be a horizontal, vertical or angular element.
5. Architectural Hanging Valleys: large and small uncovered decks usually used to help distinguish one level from the next.
6. Architectural Ledges: one or more small drops in a buildings' mass.
7. Architectural Lighting: lighting incorporated into the architecture of a building to emphasize architectural features, enhance the public realm, and create a safe pedestrian experience.
8. Architectural Peaks: the top of a building that is narrower than the base and middle.
9. Articulations: street fronting architectural design elements that offer a change in massing, material, or design, to enhance the pedestrian realm and break up the building facade.
10. Attached Single-Family Housing: a classification of housing where multiple housing units exist in one project and share at least one wall.
11. Building Base: an architectural term. The base of the building typically should not extend beyond the first two or three stories of a building.
12. Building Frontage: the first two stories or twenty feet of a building facade along a right of way. Buildings may have more than one frontage. In these cases, buildings shall have a primary frontage and a secondary frontage(s).
13. Building Middle: an architectural term. The middle of the building should define the building with multiple, varied planes that give the appearance of architectural canyons, crevices, cliffs, and ledges. The middle includes elements that break up the building into multiple small elements and planes instead of one or two large elements.
14. Building Top: an architectural term. The building top should be tapered from the rest of a building or made to look different through use of materials and articulations. The building top is the top story or two of a building. For smaller buildings (four stories or less), the top consists of the roof and cornice treatment.
15. Building Space: the area within the pedestrian realm provided to display merchandise, provide temporary signage, enhance entryways, provide outdoor seating or dining, or provide a stoop for residential uses.
16. Bulb-outs: areas of sidewalks extended into the roadway to provide safer pedestrian crossings and to calm traffic.
17. Casual Dining: a restaurant that provides table service and moderate prices with a casual atmosphere.
18. Community Space: a public area for the community to gather, interact, and participate in unstructured recreation.
19. Counter Service Dining: a restaurant with walk-up order service and no reserved seating.
20. Crosswalks: public areas for pedestrians to cross safely from one path to another in the vehicle travel area.
21. Density: the number of dwelling units per acre of land.
22. Facade: the exterior wall of a building.
23. Fenestration: the transparency of the building. More windows and doors on the ground level of your business will make pedestrians feel safer, thereby increasing pedestrian activity.
24. Fine Dining: a restaurant with table service, high quality menus, and a formal atmosphere.

25. Gateway: an entrance corridor that heralds the approach of a new landscape or defines the arrival point as a destination.
26. Green Roofs: a vegetative layer grown on a rooftop designed to reduce the urban heat island effect and manage storm water.
27. Hardscape: hard, non-living materials (such as rocks, pavers, woodchips) that are incorporated into a landscape.
28. Iconic Architecture: when a building's architectural costs exceed a 50% construction cost increase when compared to the average for the same building type in The Cairns. Measured on a per square foot basis.
29. Landmark: a readily identifiable physical or graphic element that creates a point of reference and helps a user navigate to their destination and determine their location.
30. Landscape Space: a landscape or hardscape area between the front face of curb and the area for pedestrian travel in the pedestrian space, used for parkstrip treatments.
31. LEED: an ecologically-oriented building certification program that recognizes best-in-class building strategies and practices administered by the U.S. Green Building Council.
32. LID (Low Impact Design): systems or practices that use or mimic natural processes to manage storm water through infiltration and evapotranspiration to protect water quality and associated aquatic habitat.
33. Live Entertainment Venue: an establishment of which the main purpose is showing live entertainment
34. Loading Docks: an unobstructed area provided and maintained for the temporary parking of trucks and other motor vehicles for the loading and unloading of goods.
35. Meander: a winding path or course, rather than a straight path.
36. Monument Sign: a freestanding sign supported primarily by an internal structural framework or integrated into landscaping or other solid structural features other than support poles.
37. Multi-Family Housing: a classification of housing where multiple separate housing units are contained within one building or several buildings within one complex. To be a multi-family project, there must be separate living units above and below each other. A common form is an apartment building.
38. Neighborhood Open Space: a large open space for a wide range of activities.
39. On-street Parking: the storage space for an automobile that is located within the street right-of-way.
40. Open Space: land and water areas set for use as unstructured recreation areas or for resource protection. Often offers visual relief in developed areas.
41. Outdoor Storage: the keeping of personal or business property in a required open parking space or any other location outside a building for a period of time exceeding 72 consecutive hours.
42. Parkstrip: the landscaped area between the back of curb and the pedestrian right of way.
43. Pedestrian Mew: a narrow, inviting pedestrian path with buildings on either side. Also known as a block break.
44. Pedestrian Realm: the space inside the public realm between the top back of curb and the building facade. This realm has three components: pedestrian space, building space, and landscape space
45. Pedestrian Space: the area within the pedestrian realm designated for the movement and circulation of pedestrians.
46. Pedestrian Refuge: raised islands in the center of the street along a crosswalk to provide pedestrians a protected "island" in the road to make the crossing distance shorter.
47. Plane (in reference to buildings): any contiguous surface of the exterior facade of a building at the same distance from the property line as it is vertically extended, that also has a minimum dimension of 10 feet by 8 feet. Columns and the like will not be considered a plane.

- 
48. Plaza: an open space provided for unstructured recreation for small to medium sized gatherings located in active locations.
  49. Pocket Open Space: a small open space designed for the rest and recreation of urban dwellers.
  50. Pole Sign: a freestanding sign that is affixed, attached, or erected on a pole that is not itself an integral part of or attached to a building structure.
  51. Right of Way Encroachment: an allowed use of private property in the pedestrian right of way, so long as it does not restrict the minimum clear walkway.
  52. Roof Mounted Equipment: equipment mounted onto the roof of a structure such as fans, vents, and air conditioning units.
  53. ROW (Right of Way): a strip of land taken or dedicated for use as a public way. In addition to the roadway, it normally incorporates curbs, park strips, sidewalks, lighting, and drainage facilities.
  54. Screening: a method of visually shielding or obscuring an abutting or nearby use or structure from another by fencing, walls, berms, or densely planted vegetation.
  55. Site Grade: the surface of the ground or pavement at a stated location as it exists prior to disturbance in preparation for a project.
  56. Small Scale Consumer Goods: a small retail location selling goods for the use of the consumer
  57. Softscape: vegetation (such as shrubs and flowers) that is incorporated into a landscape.
  58. Square: a mostly green, open space designed to accommodate large gatherings and events.
  59. Stepback: a building wherein the upper section is farther back from the lower. Designed to enhance the pedestrian experience.
  60. Street Frontage: the area of a property running parallel to the street
  61. Street Design-type: an area where certain additional requirements are superimposed upon a base zoning district or underlying district in order to modify or supplement existing regulations of distinguishing circumstances.
  62. Streetscape: a design term referring to all the elements that constitute the physical makeup of a street. (i.e. building frontage, street paving, street furniture, landscaping, etc)
  63. Structured Parking: a structure or portion thereof ,composed of one or more levels of floors used exclusively for the parking or storage of motor vehicles. Open to public use.
  64. Surface Parking: an open, hard-surfaced area, other than street or public way, to be used for the storage of vehicles for a limited period of time that is available to the public; whether for compensation, free, or as an accommodation to clients or customers.
  65. Trail Sign: a sign indicating the starting and ending points to a path or trail. Often freestanding at any entrance to a trail.
  66. Vehicular Realm: the area measured between front face of curbs on a street and include everything from street parking to bikes lanes, transit lanes, vehicular lanes, etc.
  67. Wall Mounted Equipment: equipment, such as meters, mounted on the wall of a structure.

# Appendix

---

Appendix A - Required process

Appendix B - Preapproved furnishings

Appendix C - Plant list

Appendix D - List of requirements and exceptions

THE  
**CAIRNS**

# Appendix A

---

## THREE-PHASE SITE DEVELOPMENT REVIEW PROCESS

The following review process shall be required for all new or modified development proposals within The Cairns.

---

### Phase I

**1. Pre-Design Meeting.** To help expedite review of a development proposal within The Cairns, prior to submitting an application for site plan review, persons interested in undertaking development (including developer, engineer, architect and landscape architect) may meet informally with a member(s) of the Community Development Department, and other departments as necessary, to become acquainted with the substantive and procedural requirements of this Code and to review initial design plans and concepts. Staff will provide constructive feedback to ensure the applicant is on the path to compliance with the intent and design standards of The Cairns.

A second pre-design meeting may be scheduled if the City Staff and/or the applicant requests another meeting to discuss the design standards in The Cairns. A presentation to the Planning Commission during an executive meeting and/or a meeting with The Cairns Branding Committee may be scheduled as determined by City Staff.

**2. Development Review Meeting.** At this meeting, the various departments (Community Development Department, Public Works Department, Public Utilities Department, City Attorney's Office, Building & Safety Division, Fire Department, Police Department, Parks and Recreation Department, and the Department of Economic Development) shall assess the development proposal and information submitted and make suggestions to the prospective developer with respect to the proposal's compliance with the provisions of the appropriate regulations of The Cairns Design Standards, the City Development Code, the International Building Code, and any other applicable ordinances or codes of Sandy City and provide information concerning the City's review requirements and procedures.

**3. Cairns Architectural Review Committee.** In order to receive additional professional review and comment concerning buildings to be erected in The Cairns, each proposed building shall be reviewed for its architectural design, colors, and materials as outlined in chapter 5 of this document by individuals including a member of the Planning Commission, a member of the City Council, a member of the Planning Staff, three architects, and one person from the Sandy business community. These individuals, who generally will meet together, will forward their recommendation of compliance to the Community Development Director, or the Planning Commission if applicable. A second meeting may be required if requested by The Cairns Architectural Review for additional review.

- a. The Planning Commission, City Council, and Community Development Director will select their representative from their members. The architects and Sandy business member will be selected by the Mayor.
- b. There will be no regular meeting times. Meetings will be arranged on an "as needed" basis. The Planning staff member will attempt to arrange a meeting within seven days after submission of plans and request from an applicant.

---

## Phase II

**1. Preliminary Application.** An application for development that requires site plan review must be submitted to the Community Development Department and must contain the information and be in the format required by The Cairns Design Standards Checklist available from the Community Development Department. The application must include the following:

- a. General Development Application Form.
- b. An overall master plan for phased development and neighboring property.
- c. Site plan.
- d. Landscaping and irrigation plan.
- e. Architectural building elevations.
- f. Grading and drainage plan.
- g. Utility plan.
- h. Road plan and profiles.
- i. Other studies and analyses as required by staff, or Planning Commission (if applicable) that may include geotechnical studies, traffic impact analysis, market feasibility analysis, water needs analysis, etc.
- j. Adjacent property information.
- k. Names and addresses of property owners within 500 feet of the proposed project on mailing labels from the Salt Lake County Recorder's Office (when required by staff).
- l. Property plat from the Salt Lake County Recorder's Office showing the area to be developed.
- m. Fees as established by City Council.
- n. Storm Water Pollution Prevention Plan (SWPPP) and Notice of Intent (NOI) where required. For projects that warrant compliance with the UGCP, the SWPPP is to be set up and managed via an internet-based management system.
- o. Post-Construction Storm Water Maintenance Plan where required.

**2. Preliminary Site Plan Review.** Upon submittal of an application and supporting information and completion of phase one of the three phase development process, the site plan shall be forwarded to the reviewing departments and outside agencies who shall review the preliminary drawings to determine if the plan, together with all supporting information, is complete and complies with all the requirements of The Cairns Design Standards, applicable City Code and City regulations, and outside agency regulations.

---

If the departments and agencies reviews determine that all required, necessary, and requested information has not been submitted or that some of the specifics of the plan or information do not comply with the requirements of The Cairns Design Standards and the City Development Code, the applicant shall be notified in writing and on the plans of any deficiencies, comments, corrections, and requirements (including additional information and/or studies) to be addressed. These corrections may be discussed in a redline review meeting as determined by City Staff. The revised plan and all required, necessary, and requested supporting information must be resubmitted after the appropriate additions and/or corrections are made in order to complete the application.

Upon second preliminary submittal, the site plan will again be forwarded to the reviewing departments and agencies. The applicant shall be required to resubmit the plan and supporting documents to the City until all departments and agencies determine it is complete and complies with the requirements of The Cairns Design Standards, applicable City Code and City regulations, and outside agency regulations. Failure to submit complete information will result in written notification to the applicant that the review cannot proceed further until all required, necessary, and requested information is submitted.

**3. Code Compliance Determination.** Once all of the reviewing departments and agencies have reviewed the preliminary site plan, the Community Development Director shall determine if all of the design standard requirements have been complied with. If there are any exception(s) (as determined by the Community Development Director) that the applicant is requesting, the Community Development Department will schedule a Planning Commission meeting where the requested exception(s) will be reviewed. If there are no exceptions to the design standards, the applicant shall submit for final review.

**4. Planning Commission Review (if applicable).** If an applicant requests an exception(s) to any Cairns Design Standards requirement, the Planning Commission has the authority to consider the exception(s) and require at least one or more development enhancements listed in chapter 9 of this document in exchange for granting relief from any of the standards found herein. The applicant shall submit a written request and justification as to why the Planning Commission should grant relief to any of The Cairns Design Standards.

**5. Final Site Plan Review.** After review by the departments, agencies, and Planning Commission, if required, the applicant shall submit a final site plan together with all supporting documents that comply with all requirements, corrections, additions, etc. required by the departments, agencies, and Planning Commission to the Community Development Department.

The Community Development Department, along with the other reviewing departments and agencies, shall review the site plan and supporting information to determine compliance with all requirements, corrections, additions, etc.

If the departments' and agencies' reviews determine that all required, necessary, and requested information has not been submitted or that some of the specifics of the plan or information do not comply with the requirements of this Code, the applicant shall be notified in writing and on the plans of any deficiencies, comments, corrections, and requirements (including additional information and studies) to be addressed. These corrections may be discussed in a redline review meeting as determined by City Staff. The revised plan and all required, necessary, and requested supporting information shall be resubmitted after the appropriate additions and corrections are made in order to complete the application.

Upon second final submittal, the site plan will again be forwarded to the reviewing departments and agencies. The applicant shall resubmit the plan and supporting documents to the City until all departments and agencies determine it is complete and complies with the requirements of The Cairns Design Standards, the City Development Code, and other applicable City and agencies' standards. Failure to submit complete information will result in written notification to the applicant that the review cannot proceed further until all required, necessary, and requested information is submitted.

---

A signed Post-Construction Storm Water Maintenance Agreement shall be submitted with the final plan set where required. The agreement is to be recorded after completion of the project. For residential development, the agreement shall be referenced in and recorded with the restrictive covenants of the Home Owners Association.

- a. Grading Permit. A grading permit may be issued prior to final site plan approval, subject to the approval of the City Engineer, together with a guarantee in an amount to be determined by the City Engineer. No utilities may be installed until final site plan approval is received.
- b. Building Plans. A set of building plans may be submitted for a preliminary plan check. The official building permit will not be issued until all requirements in Phase III have been completed.

---

## Phase III

**1. Site Plan Approval.** When the Director makes the determination that the final site plan is complete and complies with all the requirements, the plan will be stamped and signed by the Community Development Director, the Planning staff member handling the review, the Chief Engineer of the Public Utilities Department, the City Engineer, the City Transportation Engineer and, if required, the Parks and Recreation Department staff member handling the review.

**2. Signed Drawings.** Once signed by all appropriate City departments, the site plan, civil drawings, and landscape/irrigation plans, along with the Agreement to Conditions, shall be signed by the developer. All site plan sets, improvement guarantees, improvement agreements, and the Agreement to Conditions must be signed by the same person.

**3. Fees and Guarantees.** In addition to the above, any required items not previously submitted, including any required dedication documents, fees, improvement guarantees, and improvement agreements must be submitted at this time before a building or construction permit may be issued.

*An application will be considered complete once the requirements of Phase I, Phase II and paragraphs 1, 2, and 3 of Phase III have been met as determined by the Community Development Director.*

**4. Plans Kept On-Site.** A copy of the approved and signed site plan, civil drawings, landscape/irrigation plans, and approved building plans shall be kept on the construction site at all times.

**5. Pre-Construction Meeting.** Once the final site plans have been signed and all fees and bonds have been paid, the City Engineer will coordinate and conduct a pre-construction meeting with the developer, contractor, and City staff. After this pre-construction meeting, the developer may begin construction of the site.

**6. Building Permit.** Once the final building plan sets have been approved, site plan approved, development fees paid, the guarantee for improvements put in place, and a pre-construction meeting has taken place, then a building permit may be issued to begin construction of permanent structures.

---

# Appendix B

---

## PRE-APPROVED PUBLIC REALM FURNISHINGS - LAST UPDATED 2017

The following list of public realm furnishings is always acceptable for new or redeveloping projects in The Cairns without further review or approval

---

### TRASH RECEPTACLES:

- a. Forms + Surfaces | Apex Receptacle
  - b. Anova | Airi Receptacle
- 

### BIKE RACKS:

- a. Forms + Surfaces | Bike Garden
  - b. Forms + Surfaces | Trio Bike Rack
- 

### BENCHES:

- a. Anvoa | Airi Bench
  - b. Landscape Forms | Strata Beam Bench
  - c. Forms + Surfaces | Boardwalk Bench
  - d. Landscape Forms | Milenio
- 

### TREE GRATES:

- a. Iron Age | Regular Joe
- b. Ironsmith | Metro
- c. Urban Accessories | Jamison
- d. Iron Age | Oblio
- e. Ironsmith | Via Rizo
- f. Urban Accessories | Chinook 2000
- g. Iron Age | Locust



# Appendix C

## PLANT LIST - LAST UPDATED 2017

### CONIFEROUS TREES

\* - Indicates Utah native

● - Indicates trees suitable for streetscape application

| Botanical Name                                 | Common Name               | Size (H x W)       | Notes  |
|--|---------------------------|--------------------|--|
| ● <i>Abies concolor</i>                        | White Fir                 | 40'-70' x 20'-30'  |  |
| ● <i>Calocedrus decurrens</i>                  | Incense Cedar             | 30'-50' x 8'-10'   |  |
| <i>Cedrus atlantica</i>                        | Blue Atlas Cedar          | 40'-60' x 30'-40'  |  |
| ● <i>Juniperus scopulorum</i>                  | Rocky Mountain Juniper    | 10'-25' x 5'-15'   |  |
| ● <i>Larix occidentalis</i>                    | Western Larch             | 30'-60' x 15'-20'  | Prefers moist soil; deciduous conifer  |
| ● <i>Metasequoia glyptostroboides</i>          | Dawn Redwood              | 70'-100' x 15'-25' | Prefers moist soil; deciduous conifer  |
| ● <i>Picea abies</i>                           | Norway Spruce             | 40'-60' x 25'-30'  |  |
| <i>Picea engelmannii</i>                       | Engelmann Spruce          | 70'-100' x 10'-15' | May struggle in valley locations; no heavy clay soils; prefers moist soil; use sparingly |
| <i>Picea glauca</i> 'Densata'                  | Black Hills Spruce        | 20'-30' x 10'-15'  |  |
| * <i>Picea pungens</i>                         | Colorado/Blue Spruce      | 30'-60' x 10'-20'  | May struggle in valley locations; use sparingly  |
| * <i>Pinus aristata</i> /longaeva              | Bristlecone Pine          | 8'-20' x 10'-20'   |  |
| * <i>Pinus edulis</i>                          | Pinyon Pine               | 20'-30' x 10'-20'  |  |
| ● <i>Pinus flexilis</i> 'Vanderwolf's Pyramid' | Vanderwolf's Pyramid Pine | 20'-30' x 10'-15'  |  |
| ● <i>Pinus nigra</i>                           | Austrian Pine             | 40'-60' x 20'-40'  |  |
| * <i>Pseudotsuga menziesii</i>                 | Douglas Fir               | 40'-80' x 12'-20'  | Prefers moist soil   |

### DECIDUOUS TREES

\* - Indicates Utah native

● - Indicates trees suitable for streetscape application

| Botanical Name                          | Common Name                 | Size (H x W)        | Notes  |
|---|-----------------------------|---------------------|--|
| * <i>Acer glabrum</i>                   | Rocky Mountain Maple        | 15'-30' x 10'-15'   |  |
| * <i>Acer saccharum grandidentatum</i>  | Wasatch Bigtooth Maple      | 20'-30' x 20'-25'   | Don't use <i>Acer saccharum</i> rootstock                            |
| <i>Acer tataricum</i>                   | Tatarian Maple              | 15'-20' x 15'-20'   |  |
| * <i>Amelanchier alnifolia</i>          | Saskatoon Serviceberry      | 10'-15' x 10'-15'   |  |
| ● <i>Amelanchier x grandiflora</i>      | Serviceberry                | 15'-25' x 15' x 25' | Single and multi stem  |
| * <i>Betula occidentalis</i>            | Western Water Birch         | 10'-20' x 10'-15'   | Only use near consistently moist areas                               |
| ● <i>Celtis occidentalis</i>            | Common Hackberry            | 40'-60' x 30'-40'   |  |
| ● <i>Cercis canadensis</i>              | Eastern Redbud              | 20'-30' x 20'-25'   | May need more water in full sun                                      |
| * <i>Cercocarpus ledifolius</i>         | Curl Leaf Mountain Mahogany | 10'-20' x 8'-15'    | Semi-evergreen   |
| ● <i>Crataegus crus-galli</i> 'Inermis' | Thornless Cockspur Hawthorn | 15'-25' x 15'-20'   |  |
| ● <i>Koeleruteria paniculata</i>        | Golden Rain Tree            | 30'-40' x 25'-35'   |  |
| ● <i>Populus tremula</i> 'Erecta'       | Swedish Aspen               | 30'-40' x 6'-10'    | Somewhat less prone to disease and suckering than <i>tremuloides</i> |
| * <i>Prunus virginiana</i>              | Chokecherry                 | 20'-30' x 15'-20'   |  |
| ● <i>Prunus virginiana</i> 'Schubert'   | Canada Red Chokecherry      | 20'-30' x 15'-20'   | Purple leaves  |
| * <i>Quercus gambelii</i>               | Gambel Oak                  | 20'-30' x 15'-20'   |  |
| ● <i>Quercus macrocarpa</i>             | Bur Oak                     | 60'-80' x 60'-80'   |  |
| <i>Quercus muehlenbergii</i>            | Chinkapin Oak               | 40'-60' x 50'-70'   |  |
| ● <i>Ulmus parvifolia</i>               | Lacebark Elm                | 40'-50' x 25'-40'   | Street/shade tree  |
| ● <i>Zelkova serrata</i>                | Japanese Zelkova            | 50'-80' x 40'-50'   | Street/shade tree  |



## SHRUBS

\* - Indicates Utah native

| <u>Botanical Name</u>                   | <u>Common Name</u>         | <u>Size (H x W)</u> | <u>Notes</u>                    |
|---|----------------------------|---------------------|---------------------------------|
| <i>Buddleia davidii</i>                 | Butterfly Bush             | 5'-8' x 5'-10'      |                                 |
| <i>Caryopteris x clandonensis</i>       | Blue Mist Spirea           | 3'-4' x 3'-4'       |                                 |
| <i>Cornus alba 'Ivory Halo'</i>         | Ivory Halo Dogwood         | 4'-6' x 4'-6'       | Best in consistently moist soil |
| * <i>Cornus sericea</i>                 | Red Twig Dogwood           | 6'-10' x 6'-10'     | Best in consistently moist soil |
| <i>Cornus sericea 'Flaviramea'</i>      | Yellow Twig Dogwood        | 5'-6' x 5'-6'       | Best in consistently moist soil |
| <i>Juniperus squamata</i>               | Blue Star Juniper          | 1'-3' x 1'-4'       |                                 |
| <i>Kerria japonica</i>                  | Japanese Kerria            | 8'-10' x 6'-8'      |                                 |
| <i>Mahonia aquifolium</i>               | Oregon Grape Holly         | 5'-8' x 5'-8'       |                                 |
| <i>Philadelphus lewisii</i>             | Mock Orange                | 6'-10' x 6'-10'     |                                 |
| * <i>Philadelphus microphyllus</i>      | Littleleaf Mock Orange     | 4'-5' x 4'-5'       |                                 |
| <i>Physocarpus opulifolius</i>          | Ninebark                   | 5'-8' x 4'-6'       |                                 |
| <i>Picea abies 'Nidiformis'</i>         | Nesting Spruce             | 3'-5' x 4'-6'       |                                 |
| <i>Pinus densiflora 'Umbraculifera'</i> | Japanese Red/Tanyosho Pine | 10'-15' x 15'-20'   |                                 |
| <i>Pinus mug</i>                        | Mugo Pine                  | 15'-20' x 25'-30'   |                                 |
| <i>Pinus mugo 'Slowmound'</i>           | Slowmound Mugo Pine        | 1'-3' x 2'-3'       |                                 |
| * <i>Potentilla fruticosa</i>           | Shrubby Cinquefoil         | 3'-4' x 3'-4'       |                                 |
| * <i>Prunus besseyi</i>                 | Western Sand Cherry        | 4'-6' x 4'-6'       |                                 |
| <i>Prunus x cistena</i>                 | Purple Sand Cherry         | 6'-8' x 5'-8'       |                                 |
| <i>Rhus aromatica 'Grow-Low'</i>        | Grow-Low Sumac             | 1.5'-2' x 6'-8'     | Spreading, rambling             |
| <i>Rhus typhina</i>                     | Staghorn Sumac             | 15'-25' x 20'-30'   | Suckering                       |
| * <i>Ribes alpinum</i>                  | Alpine Currant             | 3'-6' x 3'-6'       |                                 |
| * <i>Ribes aureum</i>                   | Golden Currant             | 3'-6' x 3'-6'       |                                 |
| <i>Rosa 'Meicoublan'</i>                | Meidiland Rose             | 1'-2' x 4'-6'       | Spreading                       |
| <i>Sambucus canadensis</i>              | Elderberry                 | 5'-10' x 5'-10'     | Prefers moist soil              |
| <i>Spiraea thunbergii</i>               | Thunberg Spirea            | 3'-5' x 3'-5'       |                                 |
| * <i>Symphoricarpos albus</i>           | Common Snowberry           | 3'-6' x 3'-6'       |                                 |
| <i>Viburnum lantana 'Mohican'</i>       | Wayfaring Tree             | 6'-8' x 6'-10'      |                                 |

## ORNAMENTAL GRASSES

\* - Indicates Utah native

| <u>Botanical Name</u>               | <u>Common Name</u>           | <u>Size (H x W)</u> | <u>Notes</u>   |
|-------------------------------------|------------------------------|---------------------|--|
| * <i>Achnatherum speciosum</i>      | Desert Needlegrass           | 1'-2' x 1'-2'       |  |
| <i>Bouteloua curtipendula</i>       | Sideoats Grama               | 18"-30" x 18"-24"   |  |
| <i>Bouteloua gracilis</i>           | Blue Grama                   | 8"-24" x 8"-18"     |  |
| <i>Calamagrostis acutiflora</i>     | Feather Reed Grass varieties | 3'-4' x 2'-3'       |  |
| <i>Carex spp.</i>                   | Sedge varieties              | 12"-18" x 12"-24"   | Use approved varieties only in moist areas (accent to water features/drainage areas) |
| <i>Chasmanthium latifolium</i>      | Northern Sea Oats            | 2'-4' x 1'-2'       | Prefers moist soil; more shade tolerant than other grasses                           |
| <i>Deschampsia cespitosa</i>        | Tufted Hair Grass varieties  | 2'-3' x 1'-2'       | Prefers moist soil   |
| <i>Festuca glauca</i>               | Blue Fescue                  | 1' x 1'             |  |
| * <i>Festuca idahoensis</i>         | Idaho Fescue                 | 1'-2' x 1'-2'       |  |
| <i>Helictotrichon sempervirens</i>  | Blue Oat Grass               | 2'-3' x 2'-3'       |  |
| * <i>Leymus cinereus</i>            | Basin Wildrye                | 4'-6' x 2'-4'       |  |
| <i>Miscatanthus sinensis</i>        | Maidenhair Grass varieties   | 5'-10' x 3'-6'      |  |
| <i>Muhlenbergia reverchonii</i>     | Ruby Muhly Grass             | 2'-3' x 18"-24"     | Needs good drainage  |
| * <i>Oryzopsis/Stipa hymenoides</i> | Indian Rice Grass            | 2' x 2'             |  |
| <i>Panicum virgatum</i>             | Switch Grass varieties       | 3'-6' x 2'-4'       |  |
| <i>Pennisetum alopecuroides</i>     | Fountain Grass varieties     | 2'-3' x 2'-3'       | Needs good drainage  |
| <i>Schizachyrium scoparium</i>      | Little Bluestem              | 2'-3' x 1'-2'       |  |
| * <i>Sporobolus airoides</i>        | Alkali Sacaton               | 2'-4' x 2'-3'       |  |
| <i>Sporobolus heterolepis</i>       | Prairie dropseed             | 2'-3' x 2'-3'       |  |
| * <i>Sporobolus wrightii</i>        | Giant Sacaton                | 6'-8' x 4'-6'       |  |

## GROUNDCOVER

\* - Indicates Utah native

| <u>Botanical Name</u>              | <u>Common Name</u>           | <u>Size (H x W)</u> | <u>Notes</u>  |
|------------------------------------|------------------------------|---------------------|---|
| <i>Ajuga reptans</i>               | Ajuga, Bugleweed varieties   | 2"-4" x 12"-18"     |   |
| * <i>Arctostaphylos uva-ursi</i>   | Kinnickinnick                | 0.5'-1' x 3'-6'     |   |
| <i>Cerastium tomentosum</i>        | Snow in Summer               | 6"-12" x 8"-12"     |   |
| <i>Ceratostigma plumbaginoides</i> | Hardy Plumbag1'-2'-3'        |                     |   |
| <i>Cotoneaster horizontalis</i>    | Rockspray Cotoneaster        | 2'-3' x 8'-12'      |   |
| * <i>Fragaria spp.</i>             | Wild Strawberry varieties    | 2" x 24"            | Utah natives <i>F. vesca</i> and <i>F. virginiana</i> |
| <i>Galium odoratum</i>             | Sweet Woodruff               | 6"-12" x 8"-18"     | Use in consistently moist areas                       |
| <i>Helianthemum nummularium</i>    | Rock Rose                    | 6"-12" x 2'-3'      |   |
| <i>Juniperus horizontalis</i>      | Creeping Juniper varieties   | 12"-18" - 4'-6'     |   |
| <i>Lamium maculatum</i>            | Spotted Deadnettle varieties | 6"-12" x 2'x3'      |   |
| * <i>Mahonia repens</i>            | Creeping Oregon Grape        | 1'-2' x 2'-4'       |   |
| <i>Persicaria affinis</i>          | Himalayan Fleecflower        | 2" x 18"            |   |
| <i>Sedum spp.</i>                  | Sedum varieties              | 4"-8" x 6"-14"      |   |
| <i>Stachys byzantina</i>           | Lamb's Ear                   | 12"-18" x 36"       | Spreads by stolons; avoid overhead watering           |
| <i>Stachys officinalis</i>         | Bishop's Wort                | 18"-24" x 12"-18"   | Spreads by stolons                                    |
| <i>Symphoricarpos x chenaultii</i> | Chenault Coralberry          | 2'-3' x 6'-8'       | Sprawling, rambling                                   |
| <i>Thymus spp.</i>                 | Creeping Thyme varieties     | 1"-4" x 4"-12"      |   |
| <i>Veronica liwanensis</i>         | Turkish Speedwell            | 2" x 18"            |   |

## PERENNIALS

\* - Indicates Utah native

| <u>Botanical Name</u>                | <u>Common Name</u>          | <u>Size (H x W)</u> | <u>Notes</u>        |
|--------------------------------------|-----------------------------|---------------------|---------------------|
| * <i>Achillea spp.</i>               | Yarrow varieties            | 6"-36" x 18"-24"    |                     |
| <i>Adenophora latifolia</i>          | Lilyleaf Ladybells          | 2'-3' x 2'-3'       |                     |
| <i>Aethionema schistosum</i>         | Persian Rockcress           | 1' x 2'             | Needs good drainage |
| <i>Agastache cana</i>                | Wild Hyssop                 | 2'-3' x 2'-3'       |                     |
| <i>Agastache rupestris</i>           | Licorice Hyssop             | 2'-3' x 2'-3'       |                     |
| <i>Alchemilla mollis</i>             | Lady's Mantle               | 1'-1.5' x 1.5'-2'   |                     |
| <i>Alyssum montanum</i>              | Mountain Gold Alyssum       | 4"-6" x 1'-2'       |                     |
| <i>Amorpha canescens</i>             | Leadplant                   | 2'-4' x 2'-3'       |                     |
| <i>Amsonia hubrichtii</i>            | Blue Star                   | 2'-3' x 2'-3'       |                     |
| <i>Anacyclus depressus</i>           | Mount Atlas Daisy           | 2"-4" x 1.5'-2'     |                     |
| * <i>Anaphalis margaritacea</i>      | Pearly Everlasting          | 1.5'-2' x 1.5'-2'   |                     |
| * <i>Antennaria parviflora/rosea</i> | Pussy Toes, Pink Pussy Toes | 4" x 1'-1.5'        |                     |
| * <i>Aquilegia spp.</i>              | Columbine varieties         | 1.5'-2' x 1.5'-2'   | Cool, shady areas   |
| <i>Armeria maritima</i>              | Common Thrift               | 6" x 1'             |                     |
| <i>Artemisia spp.</i>                | Wormwood varieties          | 1'-4' x 2'-3'       |                     |
| * <i>Asclepias speciosa</i>          | Showy Milkweed              | 3' x 3'             |                     |
| <i>Asclepias tuberosa</i>            | Butterfly Milkweed          | 1'-2' x 2'          | Needs good drainage |
| <i>Aster spp.</i>                    | Aster varieties             | 1'-4' x 1'-3'       |                     |
| * <i>Astragalus utahensis</i>        | Utah Lady Finger; Milkvetch | 6" x 1'             | Needs good drainage |
| <i>Aubrieta deltoidea</i>            | Rock Cress                  | 4"-8" x 1'-2'       |                     |
| <i>Baptisia australis</i>            | False Indig3'-4' x 3'-4'    |                     |                     |
| <i>Bergenia cordifolia</i>           | Bergenia                    | 1' x 1'-2'          |                     |
| <i>Berlandiera lyrata</i>            | Chocolate Flower            | 18" x 12"           |                     |
| <i>Brunnera macrophylla</i>          | Siberian Bugloss varieties  | 1'-1.5' x 1'-1.5'   |                     |



## PERENNIALS (CONT.)

|  |                                  |                   |  |
|--|----------------------------------|-------------------|--|
| <i>Callirhoe involucrate</i>   | Poppy Mallow, Prairie Winecup    | 1' x 3'           |  |
| * <i>Campanula spp.</i>  | Bellflower varieties             | 6"-1' x 1'-2'     |  |
| <i>Centranthus ruber</i>   | Jupiter's Beard/Red Valerian     | 3' x 2'           |  |
| <i>Coreopsis spp.</i>  | Tickseed varieties (hardy)       | 1'-2' x 1'-2'     |  |
| <i>Corydalis lutea</i>   | Yellow Corydalis                 | 1'-1.5' x 1'-1.5' |  |
| <i>Dianthus spp.</i>   | Dianthus, Garden Pinks varieties | 8"-2' x 1'-2'     |  |
| <i>Dicentra spectabilis</i>  | Bleeding Hearts                  | 2'-4' x 2'-4'     |  |
| <i>Echinacea purpurea, angustifolia</i>                                    | Coneflower varieties             | 2'-3' x 1'-2'     |  |
| * <i>Epilobium canum spp.</i>  | Hummingbird Trumpet varieties    | 1'-2' x 1.5'-4'   |  |
| <i>Epimedium x rubrum</i>  | Barrenwort                       | 1' x 1'           |  |
| * <i>Eriogonum umbellatum</i>  | Sulfur Flower                    | 1' x 1'-1.5'      |  |
| <i>Erodium chrysanthum</i>   | Yellow Stork's Bill              | 6" x 1'           |  |
| * <i>Gaillardia aristata, grandiflora</i>                                  | Blanketflower varieties          | 2'-3' x 2'-3'     |  |
| <i>Gaura lindheimeri</i>   | Gaura, Whirling Butterflies      | 2'-3' x 2'-3'     |  |
| <i>Geranium sanguineum</i>   | Cranesbill                       | 1'-1.5' x 1'-1.5' |  |
| * <i>Geranium viscosissimum</i>  | Sticky Geranium                  | 2'-3' x 2'-3'     |  |
| <i>Globularia cordifolia</i>   | Leather Leaf Powder Puff         | 4"-6" x 1'-1.5'   |  |
| <i>Helianthemum nummularium</i>  | Rockrose                         | 6" x 18"          |  |
| <i>Hemerocallis spp.</i>   | Daylily varieties                | 1'-6" x 1'-3'     |  |
| <i>Heuchera spp.</i>   | Coral Bells                      | 1'-3' x 1'-3'     |  |
| <i>Iberis sempervirens</i>   | Candytuft                        | 1' x 1'           |  |
| <i>Lavandula angustifolia</i>  | English Lavender varieties       | 1'-3' x 1'-2'     |  |
| <i>Liatris punctata, spicata</i>   | Gayfeather varieties             | 1.5'-3' x 1.5'-2' |  |
| * <i>Linum lewisii</i>   | Blue Flax, Lewis Flax            | 1.5'-2' x 1.5'-2' |  |
| <i>Lychnis coronaria</i>   | Rose Campion                     | 2'-3' x 2'        |  |
| * <i>Mirabilis multiflora</i>  | Desert Four O' Clock             | 1'-2' x 3'-5'     | Needs good drainage                    |
| <i>Monarda fistulosa</i>   | Wild Bergamot, Bee Balm          | 1.5'-2' x 2'-3'   |  |
| <i>Nepeta x faassenii</i>  | Catmint                          | 1.5' x 2'-3'      |  |
| * <i>Oenothera spp.</i><br>(except <i>berlandieri</i> or <i>speciosa</i> ) | Evening Primrose varieties       | 6"-1' x 6"-2'     |  |
| * <i>Penstemon spp.</i>  | Penstemon varieties              | 2'-4' x 1'-3'     | Most need good drainage                |
| <i>Perovskia atriplicifolia</i>  | Russian Sage                     | 3'-5' x 3'-4'     |  |
| <i>Phlox subulata</i>  | Creeping Phlox                   | 6" x 1'           |  |
| <i>Pulsatilla vulgaris</i>   | Pasque Flower                    | 6" x 1'           |  |
| * <i>Ratibida columnifera</i>  | Prairie Coneflower, Mexican Hat  | 1.5'-2' x 1.5'-2' | Needs good drainage, low fertile soils |
| <i>Rudbeckia fulgida</i>   | Black Eyed Susan                 | 2'-3' x 2'-3'     |  |
| <i>Salvia nemerosa</i>   | Salvia                           | 2'-3' x 2'-3'     |  |
| <i>Salvia officinalis</i>  | Kitchen Sage                     | 2'-3' x 2'-3'     | Don't overwater                        |
| <i>Saponaria ocymoides</i>   | Rock Soapwort                    | 6" x 2'           | Spreading                              |
| <i>Scabiosa spp.</i>   | Pincushion Flower varieties      | 1'-1.5' x 1'-1.5' |  |
| <i>Scutellaria resinosa</i>  | Prairie Skullcap                 | 6"-10" x 1'       |  |
| <i>Sedum spp.</i>  | Sedum varieties                  | 1.5'-2' x 1.5'-2' |  |
| <i>Solidago canadensis</i>   | Goldenrod                        | 3'-4' x 3'-4'     |  |
| * <i>Sphaeralcea spp.</i>  | Globemallow                      | 2'-3' x 1'-2'     |  |
| <i>Tanacetum densum</i>  | Partridge Feather                | 4"-8" x 1'-2'     |  |
| <i>Thermopsis villosa</i>  | Carolina Lupine                  | 3'-5' x 2'-4'     |  |
| <i>Veronica spicata</i>  | Spiked Speedwell                 | 1'-2' x 1'-2'     |  |
| * <i>Viguiera multiflora</i>   | Showy Goldeneye                  | 2' x 3'           | Will spread and naturalize             |

# Appendix D:

## LIST OF REQUIREMENTS

### SECTION 2.2 – PARKSTRIPS

#### FORMAL PARKSTRIPS

- There shall be a minimum of one street tree for every 35 feet of frontage
- Trees shall have a two-inch caliper at the time of planting
- Trees shall be selected from the plant list in the appendix of this document or be approved by the Parks and Recreation Department

#### INFORMAL PARKSTRIPS

- Parkstrips shall include softscape treatment for at least 40% of lot frontage
- Softscape areas shall be a minimum of 70% plant material
- Parkstrips shall include at least three different trees species (from the plant list in this document or as approved by the Parks and Recreation Department)
- Trees shall have a two-inch caliper at the time of planting

#### COMBINATION PARKSTRIPS

- Street trees shall be planted with a combination (both) of the Formal and Informal treatments (see requirements for those treatments)
- There shall be a minimum of one street tree per 45 feet of frontage (from the plant list in this document or as approved by the Parks and Recreation Department)
- Trees shall have a two-inch caliper at the time of planting

### SECTION 2.3 – DESIGN PRIORITY

#### PEDESTRIAN

- Crosswalks shall be a minimum of 6 feet wide and shall include stamped or colored concrete
- Where a driveway crosses a sidewalk, the driveway shall be raised to match the adjacent sidewalk

- Pedestrian islands shall be required for crossings over 38 feet
- Bulb-outs shall be implemented where there is on-street parking

#### SHARED

- Crosswalks shall be a minimum of 8 feet wide and shall include stamped or colored concrete
- Where a driveway crosses a sidewalk, the driveway shall be raised to match the adjacent sidewalk
- Pedestrian islands shall be required for crossings over 38 feet
- Bulb-outs shall be implemented where there is on-street parking

#### VEHICULAR

- Crosswalks shall be a minimum of 6 feet wide and shall include thermal plastic
- Where a driveway crosses a sidewalk, the driveway shall be marked with stamped or colored concrete
- Pedestrian islands shall be required for crossings over 48 feet
- Bulb-outs shall be implemented where there is on-street parking

### SECTION 2.4 – TRAFFIC-CALMING

#### CROSSWALKS

- Crosswalks shall have a defined edge according to street code requirements. Borders may be added to designs as needed
- In locations where a building is present at the corner, there shall be a specialty paver plaza of 500 square feet or more in size (see figure 218)
- In locations with a monument at the corner, there shall be a specialty paver plaza of 200 square feet or more in size (see figure 217)
- Crosswalks shall offer a route from the intersection to either the building entrance or a point of interest

////////////////////////////////////

## SECTION 2.6 – BUILDING FRONTAGES

- All buildings in The Cairns shall have frontage on at least one public or private ROW or mew.

### PRIMARY FRONTAGE:

- The primary frontage shall be the frontage of a building on the smallest numbered streetscape design-type, types 2-4, where two or more frontages exist
- The primary frontage shall be the frontage that satisfies the ground floor commercial requirement (see Chapter 3)
- The primary frontage shall include the primary entrance to the building for streetscape design-types 2 and 3
- At least 70% of either the facade of the building or a community gathering space (see Chapter 9) shall be built within five feet of the minimum setback for the applicable streetscape design-type
  - For restaurant and entertainment uses, outdoor seating and dining can count towards 70%
  - For preferred uses, this can be reduced to 50%

### SECONDARY FRONTAGE:

- The secondary frontage shall be the frontage of a building on the largest numbered streetscape design-type where two or more frontages exist
- At least 70% of the facade of the building or a community gathering space (see Chapter 9) shall be built at or closer than the maximum setback for the applicable streetscape design-type
  - For restaurant and entertainment uses, outdoor seating and dining can count towards 70%
  - For preferred uses, this can be reduced to 50%

////////////////////////////////////

## SECTION 2.7 – COMMERCIAL SPACE PROVISIONS

### FLEX-COMMERCIAL SPACE

When it is not economically viable to build commercial space consistent with the requirements of this document, commercial space may be designed as flex-commercial space.

Flex-Commercial Space shall be minimally designed with all of the following elements:

- a. All necessary venting, electrical, and plumbing for a standard restaurant user
- b. Minimum ten-foot ceilings
- c. Street entrances for pedestrians

### TRANSFER OF COMMERCIAL SPACE

As a second option for relief from minimum commercial requirement required commercial space may be transferred to another building or project on the same street or within 300 feet of the building. Transfer of commercial space shall require all of the following:

- Commercial space shall be transferred on at least a 1:1 square foot ratio
- Commercial space shall be transferred to another building or project on the same street (up to 1,000 feet away) or to another building within 300 feet as long as the new project is in The Cairns
- The transferred commercial space shall not be built as flex-commercial space
- The transferred commercial space shall be constructed simultaneously with the proposed project
- Commercial space shall not be transferred away from any streetscape design-type 2 street but may be transferred to a streetscape design-type 2 street

////////////////////////////////////

## SECTION 2.8 – DRIVE-THRUS AND WALK-UP WINDOWS

- Where permitted, drive thru windows and lanes shall be behind buildings or heavily screened to eliminate or minimize the view from the public realm
- No more than one drive thru lane shall be allowed for any one business

////////////////////////////////////

## CHAPTER 3

### TYPE 1

- Design priority shall be pedestrian
- Sidewalks shall maintain a minimum 10-foot clear walkway
- The minimum building setback shall be 6 feet

- Interruptions shall be every 50 feet
- There shall be a minimum of 2 pedestrian entrances for every 200 feet of building frontage
- Drive-thrus shall be prohibited
- On-street parking shall be temporary
- The maximum retail space for any one use shall be 8,000 sq ft
  - For preferred uses, maximum retail space is 12,000 sq ft

**TYPE 2**

- Design priority shall be pedestrian
- Parkstrip treatments shall be formal
- Sidewalks shall maintain a minimum 8 foot clear walkway
- The minimum building setback shall be 10 feet
- The maximum building setback for a primary frontage shall be 15 feet and for a secondary, 20 feet
- Interruptions shall be every 50 feet
- There shall be a minimum of 4 pedestrian entrances for every 200 feet of building frontage
- The maximum block length shall be 400 feet
  - May be substituted with the creation of an accessible community gathering space with public street frontage. Must be complete with all applicable amenities, furnishings, and features.
- Drive-thrus shall be prohibited
- On-street parking shall be required
- There shall be a minimum of 30 % ground floor commercial or flex commercial and commercial or flex commercial on all block corners
- The maximum retail space for any one use shall be 8,000 sq ft
  - For preferred uses, maximum retail space is 12,000 sq ft

**TYPE 3**

- Design priority shall be shared
- Parkstrip treatments shall be informal
- Sidewalks shall maintain a minimum 8-foot clear walkway

- The minimum building setback shall be 8 feet
- The maximum building setback for a primary frontage shall be 16 feet and for a secondary, 25 feet
- Interruptions shall be every 75 feet
- There shall be a minimum of 3 pedestrian entrances for every 200 feet of building frontage
- The maximum block length shall be 400 feet
- Drive-thrus shall be limited
- On-street parking shall be required
- There shall be a minimum of 15% ground floor commercial or flex commercial and commercial or flex commercial on half of all block corners
- The maximum retail space for any one use shall be 10,000 sq ft
  - For preferred uses, maximum retail space is 12,000 sq ft

**TYPE 4**

- Design priority shall be vehicular
- Sidewalks shall maintain a minimum 10-foot clear walkway
- The minimum building setback shall be 8 feet
- The maximum building setback for a primary frontage shall be 20 feet and for a secondary, 30 feet
- Interruptions shall be every 100 feet
- There shall be a minimum of 2 pedestrian entrances for every 200 feet of building frontage
- The maximum block length shall be 500 feet
- Drive-thrus shall be limited
- On-street parking shall be limited
- There shall be a minimum of 10% ground floor commercial or flex commercial on all block corners
- The maximum retail space for any one use shall be 20,000 sq ft

////////////////////////////////////  
**SECTION 4.2 BUILDING MASSING**

- Each building facade shall have at least one horizontal break. Horizontal breaks shall be offset at least 3 feet from the building face. (See figure 408)
  - Iconic architecture as defined in this document

- All buildings shall have a distinguishable base, middle, and top as defined in this document.
- Residential, office, and hospitality use building heights in The Cairns shall be regulated by figure 409.
- All specialty uses shall go to the Planning Commission for review and approval. These uses may not be held to the same massing or building height standards as other uses. Specialty use buildings shall follow an additional review and approval process, and will be given more flexibility in their design

////////////////////////////////////

## SECTION 5.1.2 – COMMERCIAL AND HOSPITALITY ARCHITECTURAL REQUIREMENTS

### MATERIAL REQUIREMENTS

- Full brick veneer, quarried stone, architectural metals, glass, or pre-cast architectural concrete, or other high-quality material as recommended by The Cairns Architectural Review Committee (CARC), shall be used on at least 80% of building bases and 50% of building middles for all building frontages visible from public streets
  - Iconic architecture as defined in this document
- Uninterrupted horizontal expanses of 50 feet in length of any opaque material, including opaque glass, shall be prohibited on building frontages visible from public streets
- Fully transparent, clear glass shall be required on the bottom two stories or 20 feet of any building for visibility at least three feet into the building
- Mirrored or highly reflective glass is prohibited. Opaque glass is prohibited from occupiable spaces

### FENESTRATION

#### Building Base:

- 70% minimum fenestration shall be required for bottom story along building frontages facing the street
- 50% minimum fenestration shall be required for 2nd story along building frontages facing the street

#### Building Middle and Top:

- Middle and top sections shall have between 50% and 80% glass window treatments for all facades

### ENTRIES

- All retail or restaurant entries to a building shall include a material change or different articulation of the same material in and around the entry

Each entry to a building shall be articulated with at least one of the following:

- A horizontal shift in the facade of the building (at least two feet in or out) where the door is located
- A distinguishable architectural change which clearly defines the entry
- A canopy, overhang, or arch above the entrance
- Peaked roof or raised parapet structure over the door

### ARTICULATIONS

- Buildings shall include a clearly defined base, middle, and top
- At block corners, buildings shall include enhanced articulation that minimally includes a building protrusion or recessed treatment

#### Building Base:

- (Streetscape Design-Types 1, 2, 3) Horizontal building articulations for street facing walls shall be required at least every 50 feet to break up facades and create a human-scale
- (Streetscape Design-Type 4) Horizontal building articulations shall be required at least every 75 feet to break up facades
- Vertical articulations shall minimally extend to the full height of the ground floor

#### Middle and Top:

- Vertical and horizontal divisions shall be required to the extent that a variety of physical and material breaks exist in the facade
- Building facades shall include a sequence of articulations to provide architectural relief and shadowing

---

### 5.1.3 - RESIDENTIAL ARCHITECTURE:

#### MATERIAL REQUIREMENTS

- Full brick veneer, quarried stone, architectural metals, glass, or pre-cast architectural concrete, or other high-quality material as recommended by The Cairns Architectural Review Committee (CARC), shall be used on at least 80% of building bases and 50% of building middles for all building frontages visible from public streets
  - Iconic architecture as defined in this document
- Uninterrupted horizontal expanses over 25 feet in length of any opaque material shall be prohibited on all primary and secondary frontages

#### FENESTRATION

Multi-Family (see in definitions) Building Base:

- Ground floor units should include at least 40% window treatments along building frontages

Multi-Family Building Middle and Top:

- Middle and Top stories shall have between 40% and 80% glass window treatments for all facades

Attached Single-Family (see in definitions):

- Windows shall be required on building frontages

#### ENTRIES

- Ground floor units along street frontages shall include a primary entrance from the street
- Ground floor unit entrances should have a vertical separation from the adjacent sidewalk

#### ARTICULATIONS

- Buildings shall include a clearly defined base, middle, and top
- Balconies a minimum of four feet deep shall be required on at least 40% of all multi-family units
- Horizontal building articulations for building frontages shall be required at least every 25 feet to break up facades and create a human-scale
- Building protrusions or recessed treatment extending above the base of the building shall be required at block corners

---

### SECTION 5.1.4 – INSTITUTIONAL, CIVIC, AND ENTERTAINMENT USE ARCHITECTURE

#### MATERIAL REQUIREMENTS

- Full brick veneer, quarried stone, architectural metals, glass, or pre-cast architectural concrete, or other high-quality material as recommended by The Cairns Architectural Review Committee (CARC), shall be used on at least 80% of building bases and 50% of building middles for all building frontages visible from public streets
  - Iconic architecture as defined in this document
- Uninterrupted horizontal expanses over 25 feet in length of any opaque material shall be prohibited on all primary and secondary frontages

#### FENESTRATION

- No less than 50% of the ground floor on-street facing walls should include a non-reflective, transparent glass treatment for visibility at least three feet into the building

#### ENTRIES

- Entries are encouraged at all block corners
  - Each entry to a building shall be articulated with at least one of the following:
- A horizontal shift in the facade of the building (at least two feet in or out) where the door is located
- A distinguishable architectural change which clearly defines the entry
- A canopy, overhang, or arch above the entrance
- A peaked roof or raised parapet structure over the door

#### ARTICULATIONS

- Buildings shall include a clearly defined base, middle, and top
- Building protrusions or recessed treatments extending above the base of the building shall be required at block corners

#### BUILDING BASE:

- (Streetscape Design-Types 1, 2, 3) Horizontal building articulations for building frontages shall be required at least every 25 feet to break up facades and create a human-scale
- Horizontal articulations shall minimally extend to the full height of the ground floor

Middle and Top:

- Vertical and horizontal divisions shall be required to create a variety of physical and material breaks in the facade
- Building facades shall include a sequence of articulations to provide architectural relief and shadowing

////////////////////////////////////  
**SECTION 5.2 – SITE GRADE**

- The foundation of a commercial building shall not extend above four feet from the grade of the adjacent sidewalk
- The foundation of a residential building shall not extend above six feet from the grade of the adjacent sidewalk
- Retaining walls shall not exceed five feet tall measured from the footing. Walls that are stepped shall have a 10-foot separation between retaining walls

////////////////////////////////////  
**SECTION 5.3 – ROOF TREATMENTS**

- All roof top mechanical or utility equipment shall be screened (see figure 521 - 523)
- Roof treatments shall be designed to architecturally cap the building (see figure 523)

////////////////////////////////////  
**SECTION 5.4 – LIGHTING**

- Public and private street lights and parking lot lights shall be configured in a manner that minimizes the amount of light pollution or light trespass onto adjacent properties (see figure 526)
- Public street lights within the Cairns District shall be installed as per Sandy City
- Parking lots and other private outdoor spaces shall be lit with lighting that is shielded so it can only project downward (see figure 526)

////////////////////////////////////  
**SECTION 6.1.2 – SURFACE PARKING**

- Where surface parking lots are allowed between a building and the street (Public Realm), at least 50% of the street frontage shall be fronted with buildings
- Where decorative screening is required, it shall minimally include a four foot decorative wall and/or hedge
- Landscape island tree spacing may be adjusted up or down, based on the type of tree
- Landscape island trees shall be a fruitless variety tree
- Surface parking shall comply with chart 601

////////////////////////////////////  
**SECTION 6.2.2 – STRUCTURED PARKING**

- Structured parking shall comply with chart 602
- Where shown on chart 602, parking structures should only be allowed along secondary frontages
- Four-sided screening shall shade vehicles and visually screen structures from adjacent uses and streets
- Leasable ground floor commercial space or flex-commercial space in parking structures is encouraged
- Architectural screening shall minimally follow two of the articulation requirements for its associated use as outlined in Chapter 5
- Architectural screening shall include full brick veneer, quarried stone, architectural metals, glass, or pre-cast architectural concrete, or other high-quality material as recommended by The Cairns Architectural Review Committee (CARC)

**CHART 601 : SURFACE PARKING REQUIREMENTS**

| Parking Lot Requirements for Primary Frontages                                       | Streetscape Design Types |        |        |        |
|--|--------------------------|--------|--------|--------|
|  | Type 1                   | Type 2 | Type 3 | Type 4 |
| Maximum consumption of overall site  | 50%                      | 10%    | 15%    | 50%    |
| Allowed in the public realm  | L                        | N      | L      | L      |
| Maximum % of parking allowed along public frontage (not including on-street parking) | 50%                      | 0%     | 20%    | 50%    |
| Minimum surface area to be landscaped  | 15%                      | 25%    | 20%    | 15%    |
| Evenly distributed landscaping within the parking lot                                | •                        | •      | •      | •      |
| Minimum width of landscape islands   | 6 ft.                    | 6 ft.  | 6 ft.  | 8 ft.  |
| Master plan required for parking lots with 50+ surface stalls                        | •                        | •      | •      | •      |
| Minimum setback from public or private right-of-way                                  | 15 ft.                   | N      | 15 ft. | 15 ft. |
| Decorative screening required (for parking lots visible from public realm)           | •                        | N      | •      | •      |
| Minimum tree spacing for landscape islands   | 35 ft.                   | 35 ft. | 35 ft. | 35 ft. |

• = required

L = limited (discouraged)

N = not permitted

**CHART 602 : STRUCTURED PARKING REQUIREMENTS**

| Requirements  |  | Streetscape Design-Type |        |        |        |
|---|--|-------------------------|--------|--------|--------|
|   |  | Type 1                  | Type 2 | Type 3 | Type 4 |
| Allowed locations   | Behind building                            | •                       | •      | •      | •      |
|   | Side/adjacent to building                  | •                       | N      | •      | •      |
|   | In front of building                       | L                       | N      | N      | L      |
|   | Block corners                              | N                       | N      | N      | N      |
|   | Adjacent to community space                | L                       | N      | N      | N      |
| Structure screening required                                    |  | •                       | •      | •      | •      |
| Structure height limited to Primary building height             |  | •                       | •      | •      | N      |
| Structures adjacent to public realm                             | % of ground floor commercial               | 35%                     | N      | 70%    | 35%    |
|   | Architectural treatments to match building | •                       | N      | •      | •      |
| Min. setback for non-commercial treatment along public frontage |  | 6 ft.                   | N      | 10 ft. | 10 ft. |

• = required

L = limited (discouraged)

N = not permitted

---

////////////////////////////////////

### SECTION 6.3.1 – PARKING ENTRANCES

- Parking ingress and egress for a double-lane entrance shall be a maximum of 24 feet wide
- Parking ingress and egress for single-lane entrances shall be a maximum of 14 feet wide
- Parking ingresses and egresses shall be at least 60 feet from block corners for single lane entrance
- Parking ingresses and egresses shall be at least 80 feet from block corners for double lane entrance
- The number of entrances should be limited to a single ingress and egress per street frontage, per parking facility

---

////////////////////////////////////

### SECTION 7.1.1 – PUBLIC REALM FURNISHINGS

#### TREE GRATES, MANHOLE COVERS AND SIDEWALK MEDALLIONS:

- Manhole covers (with the exception of sewer district manhole covers) shall be Cairns branded and have an additional identifying marker indicating storm water, sewer, etc.
- Tree grates shall provide at least 16 square feet of permeable surface.
- Tree grates, manhole covers, and sidewalk medallions shall be crafted using high quality materials from the pre-approved list, or as per Sandy City Standard Specifications

#### TRASH RECEPTACLES:

- Privately maintained trash receptacles should be placed in the building space close to entrances but no less than one every 200 feet
- Recycling receptacles should be paired with at least 1/2 of all trash receptacles (also to be placed in the building zone and privately maintained)
- Trash receptacles shall be crafted using high-quality materials or come from the pre-approved list in Appendix B of this document

#### BIKE RACKS:

- Each project shall have one bike rack that can accommodate a minimum of 4 bicycles
- Bike racks should be on the primary frontage of a project in the building zone

- Bike racks shall be crafted using high-quality materials or come from the pre-approved list in Appendix B of this document

#### BENCHES

- Benches should be provided at a minimum of one for every 200 or 300 feet of linear frontage withing the building space
- Benches should be placed near transit, public open spaces, and shopping and dining opportunities
- Benches shall be crafted using high-quality materials or come from the pre-approved list in Appendix B of this document

#### FENCING

- Fencing in the public realm shall not be more than 80% opaque
- Fencing shall be crafted using high-quality materials. Vinyl fencing is discouraged and chain-link fencing shall not be permitted
- Fencing in the public realm shall not be taller than 40 inches

#### BOLLARDS

- Bollards in the public realm shall not be taller than 40 inches
- Decorative and lighted bollards should be crafted using high-quality materials such as wood, stone, and prefabricated plastics

---

////////////////////////////////////

### SECTION 7.2.1 – LANDSCAPING

- Shrubs, bushes, and grasses shall cover no less than 40% of all softscape areas
- There shall be a minimum of one tree planted for every 400 square feet of landscaping
- Plant materials and landscape design shall be designed to reflect the mountain elements and themes outlined in Chapter 1 of this document
- Each site shall be designed with a variety of trees, shrubs, bushes, and grasses. No fewer than three species of trees and three species of shrubs, bushes, and grasses
- Up to 50% of the landscaping may be transferred to a green wall so long as the wall starts at the ground floor and is in view of the public right-of-way

- All landscaping shall meet LID requirements
- Up to 60% of the required landscaping may be transferred to a rooftop garden and still meet the intent of these requirements
- Plants shall come from the approved plant list in Appendix C of this document

////////////////////////////////////

**SECTION 8.1.1 – PRIMARY MONUMENTS**

- Primary gateway monuments should be at least 15 feet tall

Primary gateway monuments shall use granite veneer (figure 809), lighting, (figure 812) and no less than 4 other elements from the following list:

- Evergreen trees (see figure 802 and appendix)
- Ornamental trees (see figure 803 and appendix)
- Large shrubs (see figure 804 and appendix)
- Medium height shrubs (see figure 805 and appendix)
- Ornamental grasses (see figure 806 and appendix)
- Granite rubble (see figure 807)
- Corten/dark bronze (see figure 810)
- Stainless steel (see figure 811)
- Primary gateway monuments shall be branded with The Cairns logo

////////////////////////////////////

**SECTION 8.2.1 – SECONDARY MONUMENTS**

- Secondary gateway monuments should be at least 10 feet tall

Secondary gateway monuments shall use granite veneer (figure 820), lighting (figure 821), and no less than 2 elements from the following list:

- Evergreen trees (see figure 814 and appendix)
- Medium height shrubs (see figure 815 and appendix)
- Ornamental grasses (see figure 816 and appendix)
- Granite rubble (see figure 819)
- Corten/dark bronze (see figure 822)
- Secondary gateway monuments shall be branded with The Cairns logo

////////////////////////////////////

**SECTION 8.3.1 – VEHICULAR, PEDESTRIAN, INTERPRETIVE, AND TRAIL SIGNAGE**

- Pedestrian wayfinding signage should be at least 8 feet tall
- Vehicular wayfinding signage should be at least 10 feet tall
- Print shall be easily visible on all wayfinding signage (this can be done in several ways, see images 826-828)
- All wayfinding signage shall be constructed with high-quality materials such as granite, bronze, and stainless steel
- All wayfinding signage shall be branded with The Cairns logo

////////////////////////////////////

**SECTION 9.1 – OPEN SPACES**

- All residential units in The Cairns shall be within ¼ mile (1320 feet) walking distance to a publicly accessible open space from the front or primary entrance of a unit
- All uses in The Cairns shall be within ½ mile (2640 feet) walking distance from a publicly accessible open space of any type
- In the case where open space is proposed and installed by a developer, a development and maintenance plan for the open space shall be submitted to the City

////////////////////////////////////

**SECTION 9.1.2 – POCKET OPEN SPACES**

- Pocket open spaces shall promote family activities with structured recreational opportunities
- Pocket open space should be at least 6,000 sq ft in size

////////////////////////////////////

**SECTION 9.1.3 – SQUARES**

- Squares should be somewhat screened by landscaping to enhance the “oasis” feel
- Landscaping in a square open space should consist mostly of lawns, trees, and shrubs
- Squares may include some paths and paved areas for benches, tables, or navigation of the square
- Squares should be a minimum of one acre in size

---

SECTION 9.1.4 – PLAZAS

- Plazas shall have some point of emphasis or attraction (ie: fountains, sculptures, historic element, etc.)
  - Plazas should be used in more urban, active locations as a gathering or meeting place in commercial or more intensive residential locations
  - Plazas should be mainly hardscape
  - Plazas shall have some point of emphasis or attraction (ie: fountains, sculptures, historic element, etc.)

---

SECTION 9.1.5 – NEIGHBORHOOD OPEN SPACES

- Neighborhood open spaces shall have unique features to draw pedestrians from the whole region
- Neighborhood open spaces shall accommodate a wide range of users and activities

---

SECTION 9.1.6 – BLOCK BREAKS AND PEDESTRIAN MEWS

- Pedestrian mews and block breaks should have a 20-foot minimum width
- Pedestrian mews and block breaks shall have at least two five-foot minimum clear pathways
- There should be a minimum of 20% planted softscape in pedestrian mews and block breaks
- Pedestrian mews and block breaks shall meet the standards for streetscape design-type 1 in Chapter 3 of this document

---

SECTION 11.1 – LOADING AREAS

- Loading areas shall be screened from view of the public realm with a minimum six foot decorative stone or masonry wall and vegetation
- Loading areas should not be closer than 25 feet to the public realm

---

SECTION 11.1.2 – TRASH AND WASTE DUMPSTERS

- Trash and waste dumpsters shall be placed on a concrete pad that is enclosed on three sides with a minimum six foot tall masonry wall
- Trash and waste dumpsters shall be screened from view of the public realm
- Outdoor grease traps shall be located behind buildings

---

SECTION 11.2.1 – MECHANICAL AND UTILITY BOXES

- Mechanical and utility boxes shall be screened from view in a decorative manner from the public realm
- Mechanical and utility boxes shall not be located inside a dedicated ROW except when buried. (Exceptions may be granted by Staff for traffic light boxes)
- Mechanical boxes shall be located on rooftops, inside a building, or behind a building where they are not visible from the public realm
- Commercial mechanical units that generate noise should not be allowed within 200 feet of any residential use unless noise can be dampened sufficient to limit noise area to a 50 foot radius from the mechanical unit

---

SECTION 11.2.2 – WALL MOUNTED EQUIPMENT

- Wall mounted equipment shall not be located on any primary or secondary building frontage
- Wall mounted equipment shall be screened from view of the public realm in a decorative manner

---

SECTION 11.2.3 – ROOF MOUNTED EQUIPMENT

- Roof mounted equipment shall be screened to eliminate the view of the equipment from any ground location within 350 feet
- Any roof mounted equipment five feet or taller shall be screened using walls of a matching height constructed to match the finish materials of the building

# Appendix E:

## GRAPHIC EXAMPLES OF INTERPRETIVE SIGNS

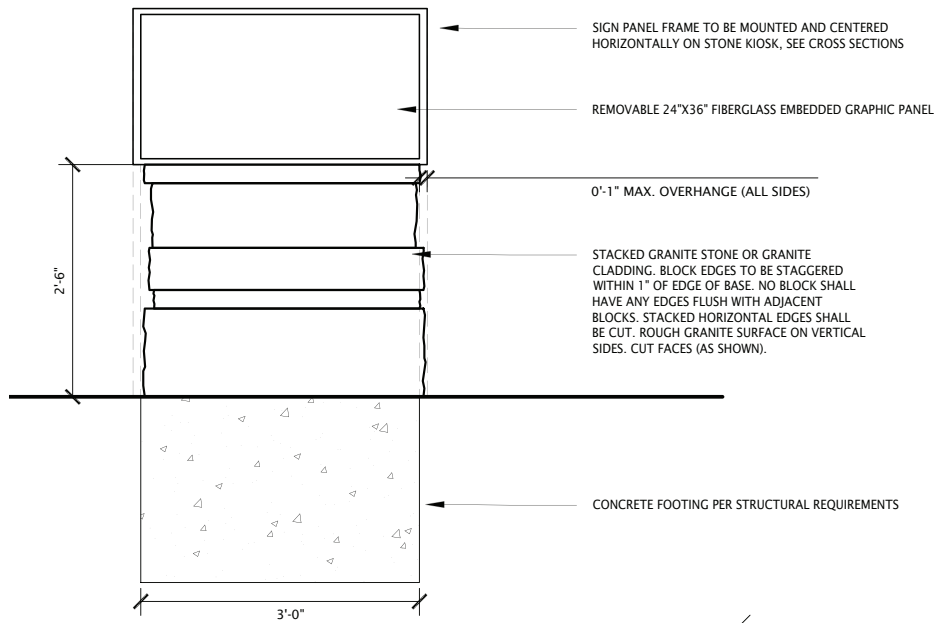

Figure E1 - Front view of Sign

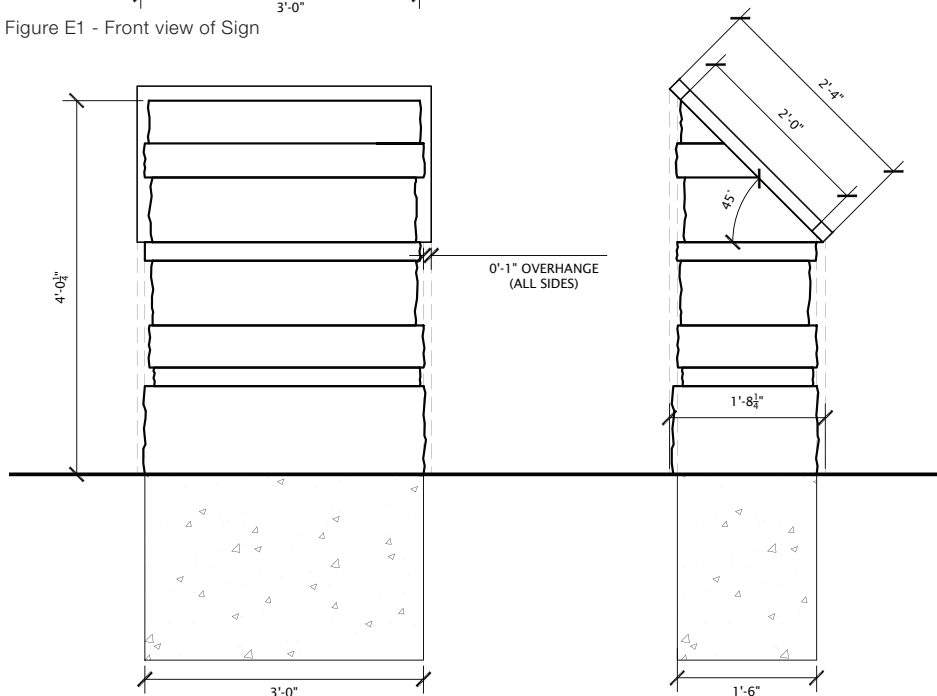

Figure E2 - Back and side of side

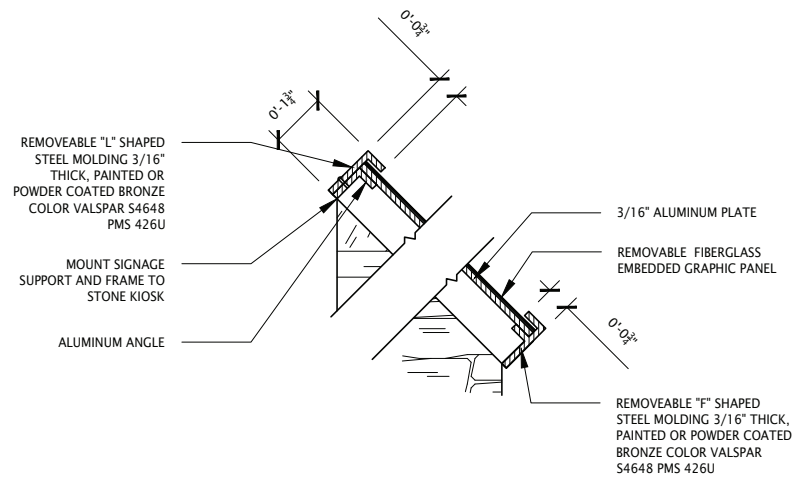

Figure E3 - Frame Cross section (side)

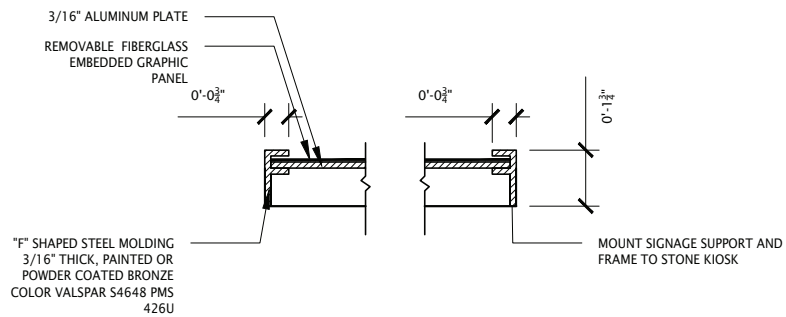

Figure E4 - Fram Cross section (top)

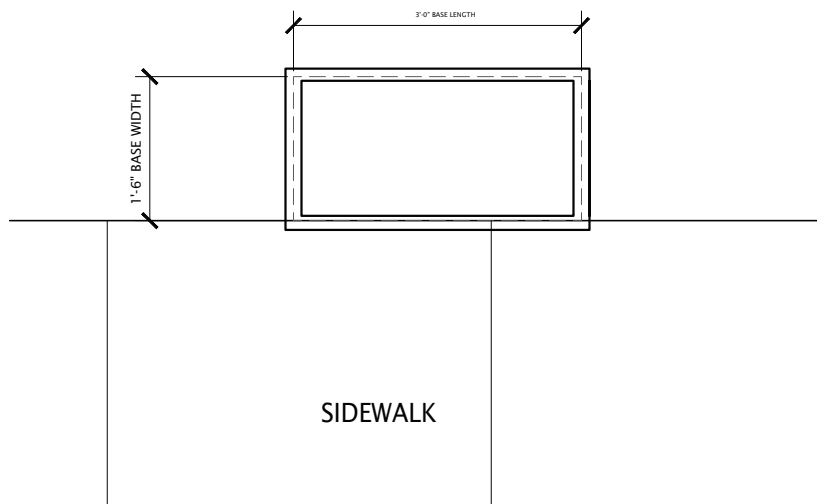

Figure E5 - Plan View

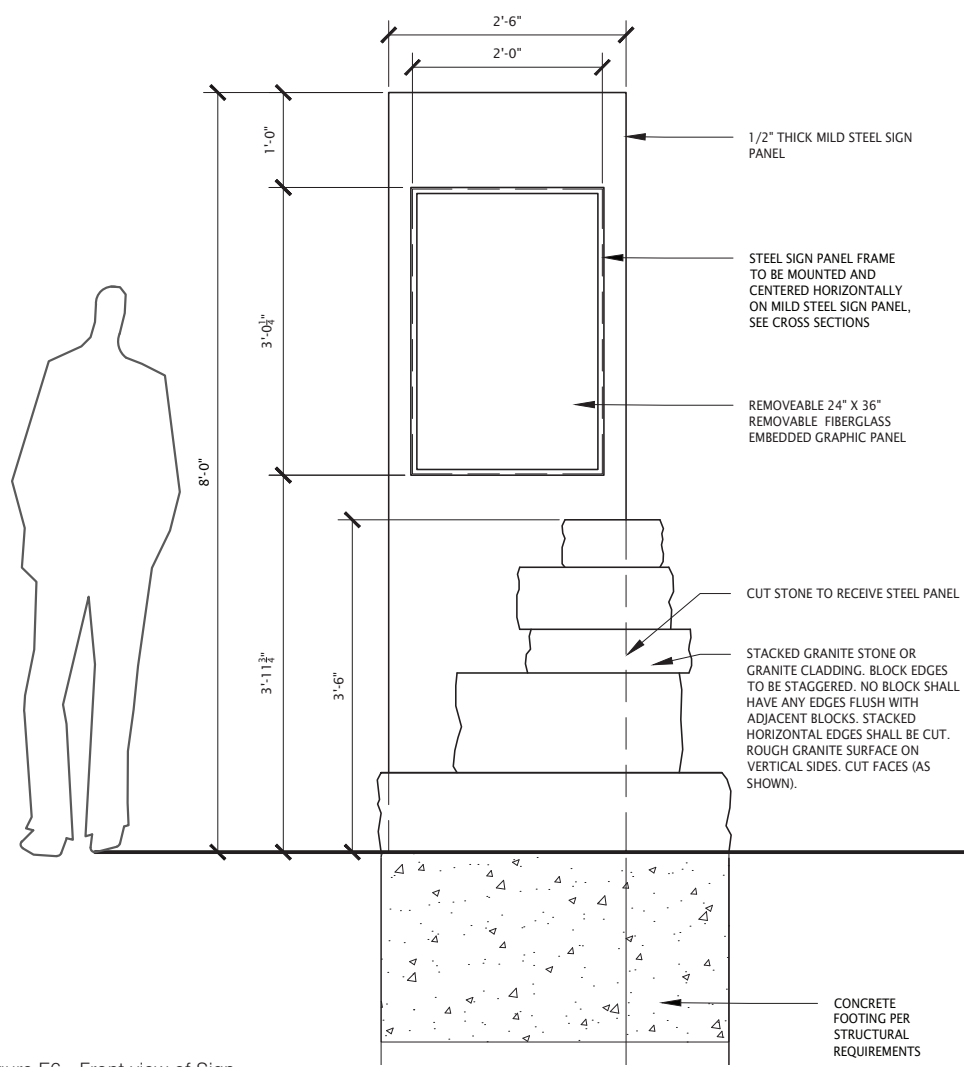
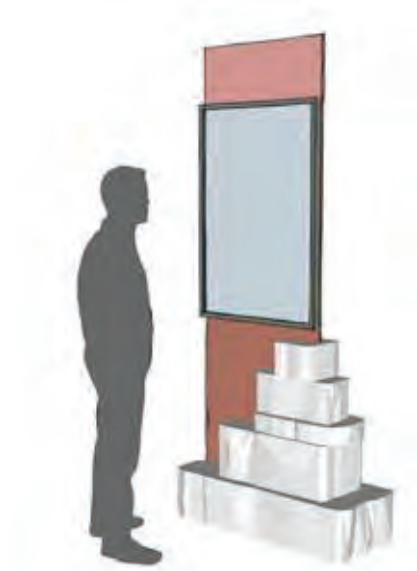

Figure E6 - Front view of Sign

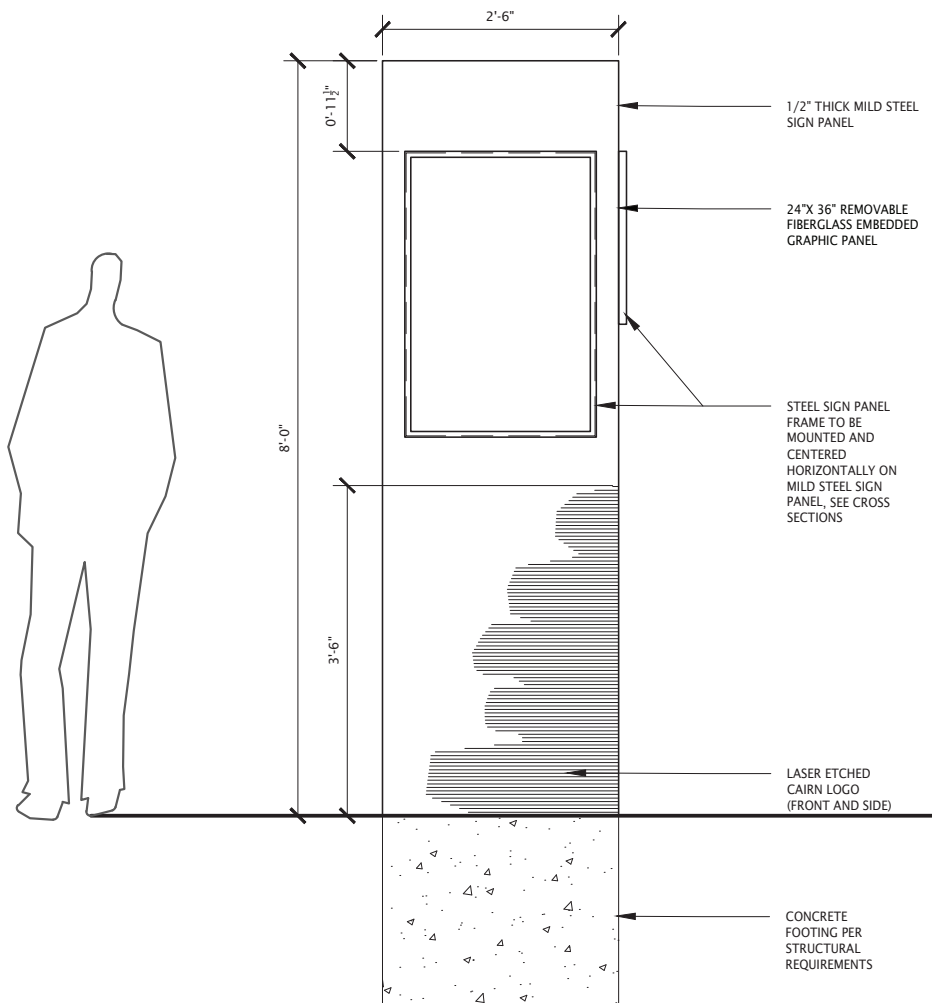

Figure E7 - Front view of Sign

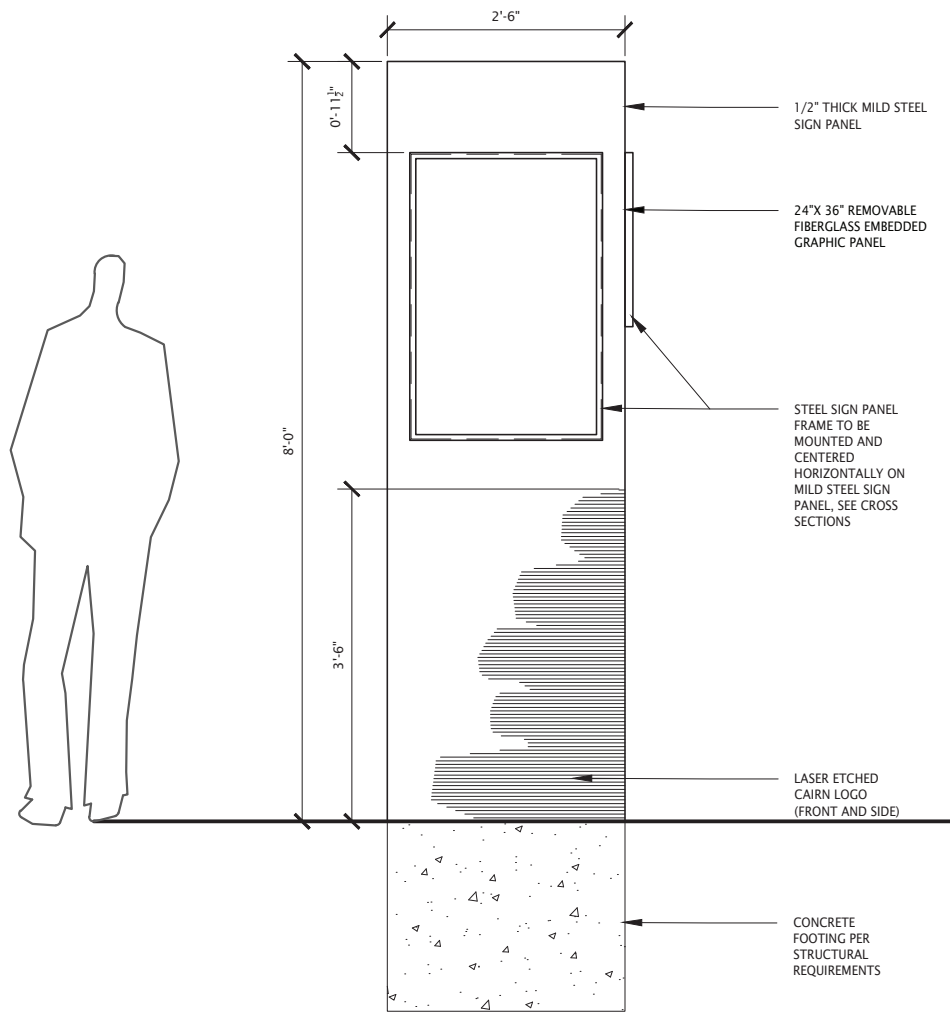

Figure E8 - Front view of Sign

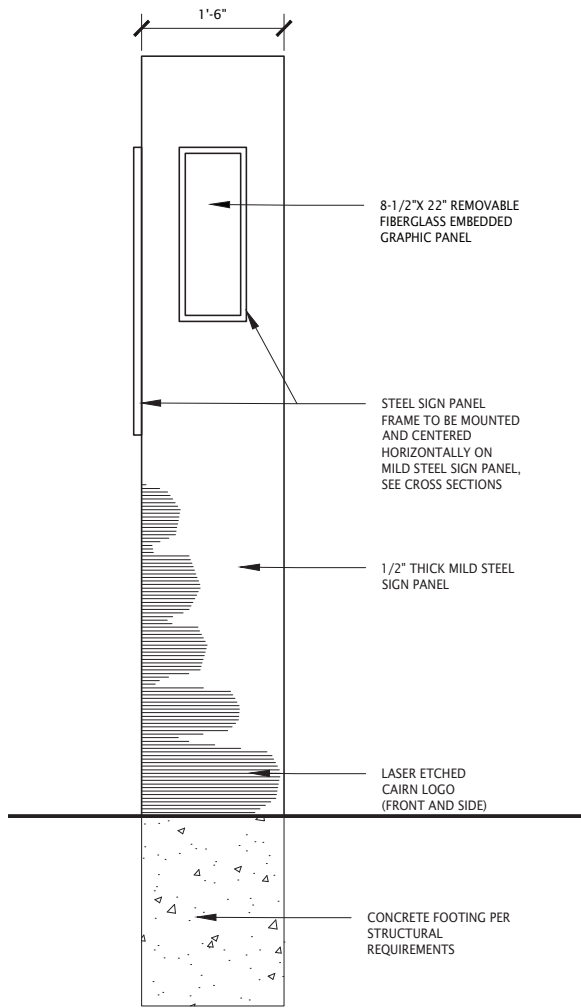

Figure E9 - Side view of Sign

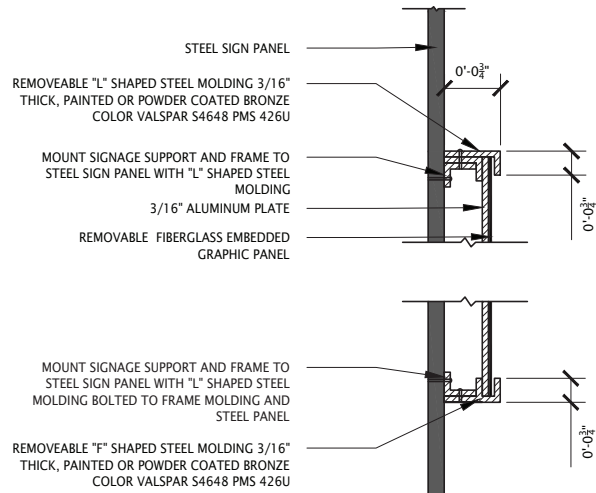

Figure \_\_\_ - Frame cross section (side)

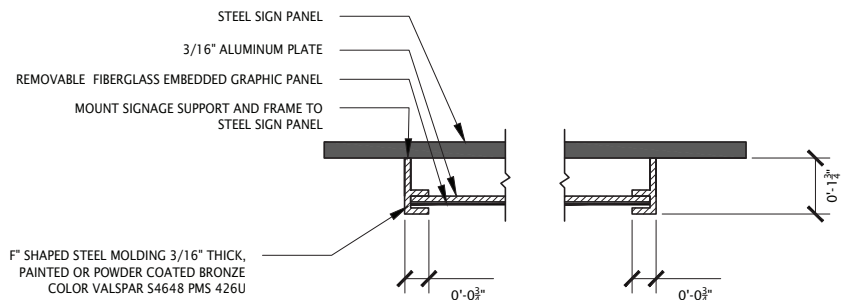

Figure \_\_\_ - Frame cross section (top)

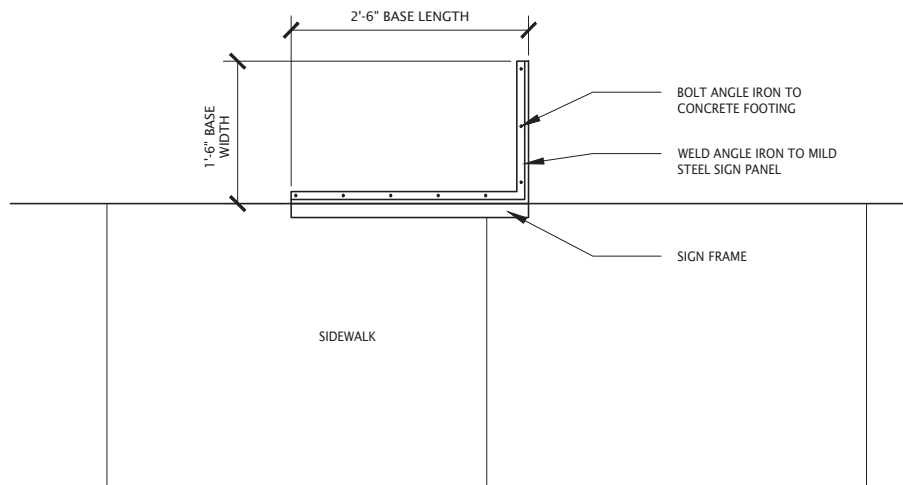

Figure E10 - Plan view of Sign

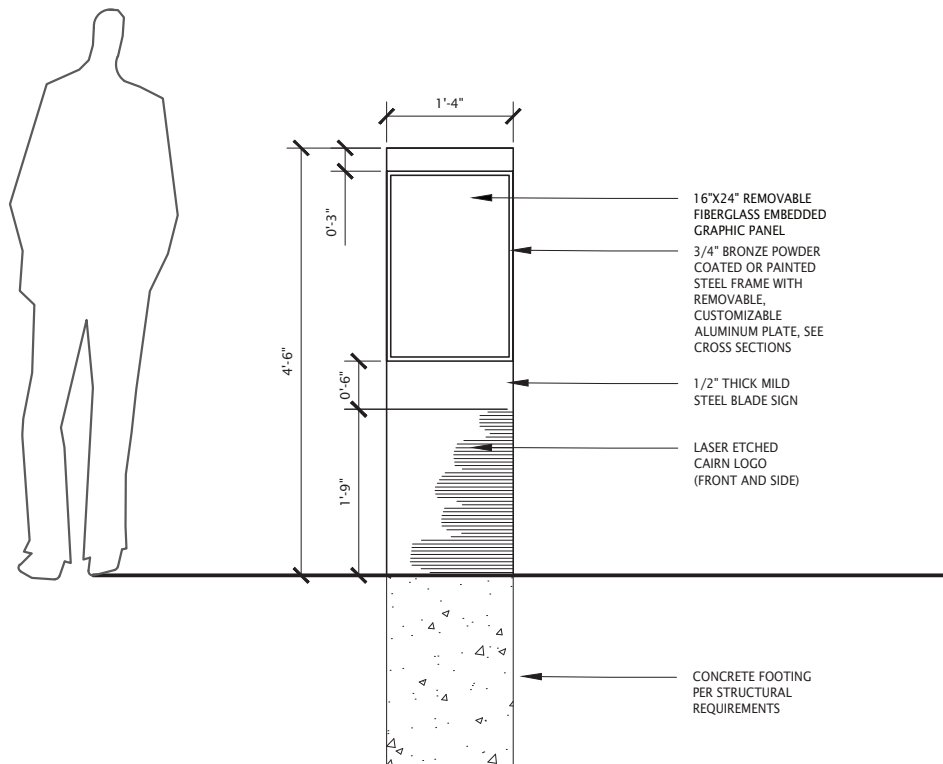

Figure E11 - Front view of Sign

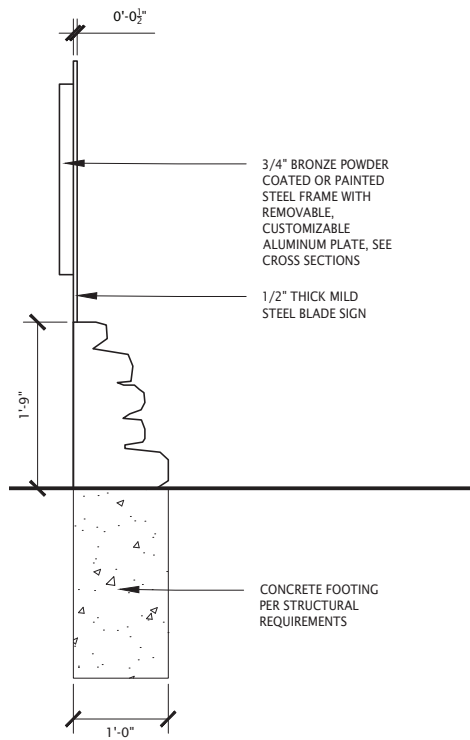

Figure E12 - Side view of Sign

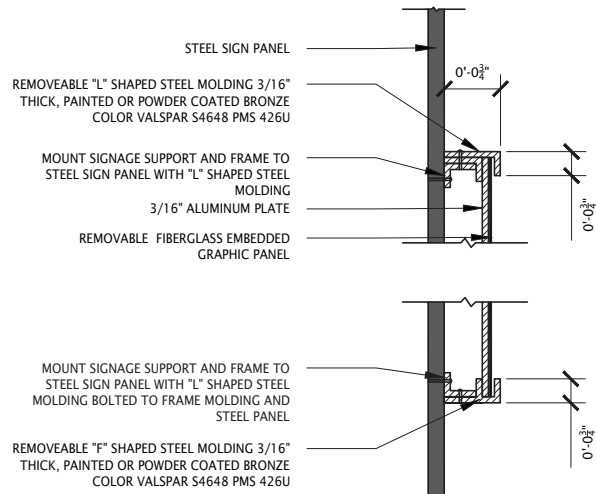

Figure E13 - Frame cross section (side)

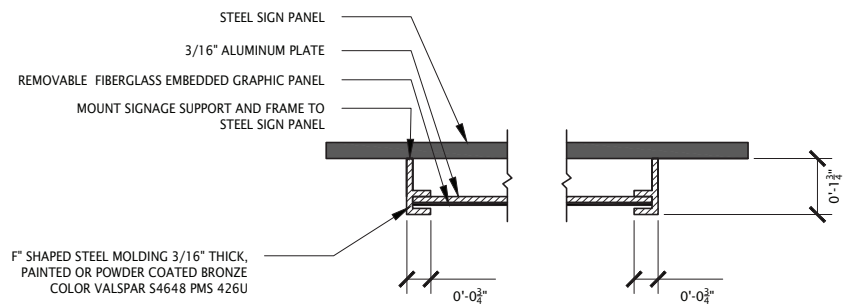

Figure E14 - Frame cross section (top)

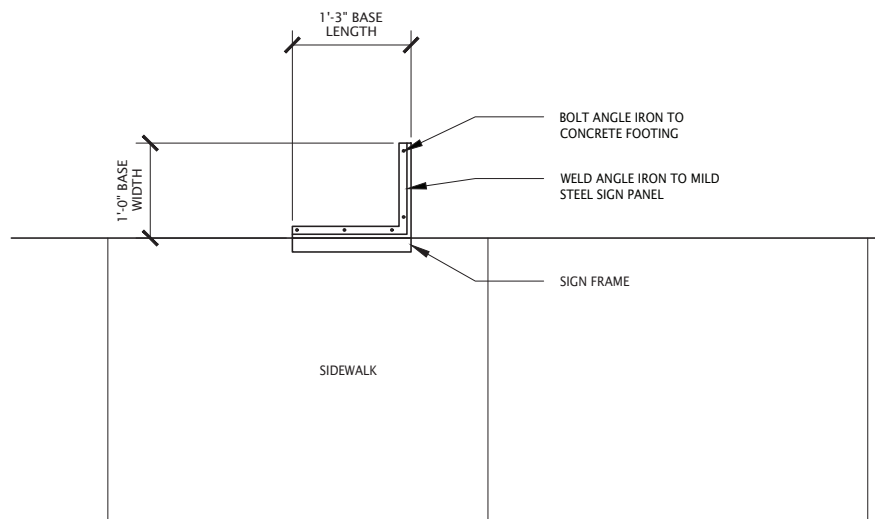

Figure E15 - Plan view of Sign

